

# KAWAI

## ES920 Owner's Manual

---

Important Information

---

Preparation

---

Basic Operation

---

Adjustments & Settings

---

Appendix

EN



# Important Safety Instructions

## SAVE THESE INSTRUCTIONS

INSTRUCTIONS PERTAINING TO A RISK OF FIRE, ELECTRIC SHOCK, OR INJURY TO PERSONS



### WARNING

TO REDUCE THE RISK OF FIRE OR ELECTRIC SHOCK, DO NOT EXPOSE THIS PRODUCT TO RAIN OR MOISTURE.

**AVIS : RISQUE DE CHOC ELECTRIQUE - NE PAS OUVRIR.**

TO REDUCE THE RISK OF ELECTRIC SHOCK, DO NOT REMOVE COVER (OR BACK). NO USER-SERVICEABLE PARTS INSIDE. REFER SERVICING TO QUALIFIED SERVICE PERSONNEL.



The lightning flash with arrowhead symbol, within an equilateral triangle, is intended to alert the user to the presence of uninsulated "dangerous voltage" within the product's enclosure that may be of sufficient magnitude to constitute a risk of electric shock to persons.



The exclamation point within an equilateral triangle is intended to alert the user to the presence of important operating and maintenance (servicing) instructions in the literature accompanying the product.

### Examples of Picture Symbols



denotes that care should be taken. The example instructs the user to take care not to allow fingers to be trapped.



denotes a prohibited operation. The example instructs that disassembly of the product is prohibited.



denotes an operation that should be carried out. The example instructs the user to remove the power cord plug from the AC outlet.

### Read all the instructions before using the product.

- 1) Read these instructions.
- 2) Keep these instructions.
- 3) Heed all warnings.
- 4) Follow all instructions.
- 5) Do not use this apparatus near water.
- 6) Clean only with dry cloth.
- 7) Do not block any ventilation openings. Install in accordance with the manufacturer's instructions.
- 8) Do not install near any heat sources such as radiators, heat registers, stoves, or other apparatus (including amplifiers) that produce heat.
- 9) Do not defeat the safety purpose of the polarized or grounding-type plug. A polarized plug has two blades with one wider than the other. A grounding type plug has two blades and a third grounding prong. The wide blade or the third prongs are provided for your safety. If the provided plug does not fit into your outlet, consult an electrician for replacement of the obsolete outlet.
- 10) Protect the power cord from being walked on or pinched particularly at plugs, convenience receptacles, and the point where they exit from the apparatus.
- 11) Only use attachments/accessories specified by the manufacturer.
- 12) Use only with the cart, stand, tripod, bracket, or table specified by the manufacturer, or sold with the apparatus. When a cart is used, use caution when moving the cart/apparatus combination to avoid injury from tip-over. 
- 13) Unplug this apparatus during lightning storms or when unused for long periods of time.
- 14) Refer all servicing to qualified service personnel. Servicing is required when the apparatus has been damaged in any way, such as power-supply cord or plug is damaged, liquid has been spilled or object have fallen into the apparatus, the apparatus has been exposed to rain or moisture, does not operate normally, or has been dropped.

**WARNING - When using electric products, basic precautions should always be followed, including the following:**



## WARNING

Indicates a potential hazard that could result in death or serious injury if the product is handled incorrectly.

**The product should be connected to an AC outlet of the specified voltage.**



- If you are going to use an AC power cord, make sure that its has the correct plug shape and conforms to the specified power voltage.
- Failure to do so may result in fire.

**Do not insert or disconnect the power cord plug with wet hands.**



Doing so may cause electric shock.

**Take care not to allow any foreign matter to enter the product.**



Entry of water, needles or hair pins may result in breakdown or short-circuit. The product shall not be exposed to dripping or splashing. No objects filled with liquids, such as vases, shall be placed on the product.

**When using the headphones, do not listen for long periods of time at high volume levels.**

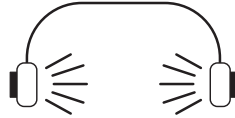

Doing so may result in hearing problems.

**Do not lean against the keyboard.**

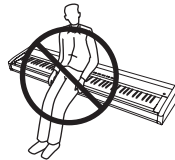

Doing so may cause the product to fall over, resulting in injury.

**Do not use the product in wet areas, or areas close to water.**



Doing so may cause a short circuit, leading to an electric shock, or a fire.

**Do not disassemble, repair or modify the product.**



Doing so may result in product breakdown, electric shock or short-circuit.

**When disconnecting the AC power cord's plug, always hold the plug and pull it to remove it.**



- Pulling the AC power cord itself may damage the cord, causing a fire, electric shock or short-circuit.

**The product is not completely disconnected from the power supply even when the power switch is turned off. If the product will not be used for a long time, unplug the AC power cord from the AC outlet.**



- Failure to do so may cause fire in case of lightning.
- Failure to do so may over-heat the product, resulting in fire.

**This product may be equipped with a polarized line plug (one blade wider than the other). This is a safety feature. If you are unable to insert the plug into the outlet, contact an electrician to replace your obsolete outlet. Do not defeat the safety purpose of the plug.**

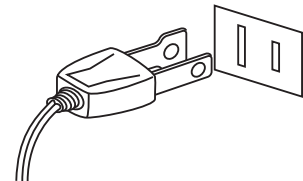

**This product shall be near the AC outlet and the power cord plug in a position so that it can readily be disconnected in an emergency because electricity is always charging while the plug is in the AC outlet even in a power switch off condition.**



# CAUTION

Indicates a potential hazard that could result in injury or damage to the product or other property if the product is handled incorrectly.

**Do not use the product in the following areas.**

- Areas, such as those near windows, where the product is exposed to direct sunlight
- Extremely hot areas, such as near a heater
- Extremely cold areas, such as outside
- Extremely humid areas
- Areas where a large amount of sand or dust is present
- Areas where the product is exposed to excessive vibrations

Using the product in such areas may result in product breakdown. Use the product only in moderate climates (not in tropical climates).

- Do not stand the main unit on its side for extended periods of time.
- Do not attempt to play the main unit at unusual angles.

Doing so may place stress on the keyboard action, resulting in breakdown of the product.

**Use only the AC adaptor included with this instrument to power the instrument.**

- Do not use other AC adaptors to power this instrument.
- Do not use the included AC adaptor or AC power cord to power other equipment.

**Before connecting cords, make sure that the power to this product and other devices is turned OFF.**



Failure to do so may cause breakdown of this product and other devices.

**Do not drag the product on the floor. Take care not to drop the product.**

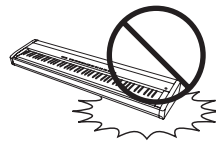

Please lift up the product when moving it. Please note that the product is heavy and must be carried by more than two persons. Dropping the product may result in breakdown.

**Do not place the product near electrical appliances such as TVs and radios.**

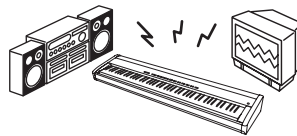

- Doing so may cause the product to generate noise.
- If the product generates noise, move the product sufficiently away from the electrical appliance or connect it to another AC outlet.

**When connecting the AC power cord and other cords, take care not to get them tangled.**



Failure to do so may damage them, resulting in fire, electric shock or short-circuit.

**Do not wipe the product with benzene or thinner.**



- Doing so may result in discoloration or deformation of the product.
- When cleaning the product, put a soft cloth in lukewarm water, squeeze it well, then wipe the product.

**Do not stand on the product or exert excessive force.**



- Doing so may cause the product to become deformed or fall over, resulting in breakdown or injury.

**Do not place naked flame, such as lighted candles on the product.**



Doing so may cause the illumination to fall over, resulting in fire.

**Ensure that the ventilation is not impeded by covering the ventilation openings with items, such as newspaper, table-cloths, curtains, etc.**



Failure to do so may over-heat the product, resulting in fire.

**The product should be located so that its location or position does not interfere with its proper ventilation. Ensure a minimum distance of 5cm around the product for sufficient ventilation.**

**The product should be serviced by qualified service personnel when:**

- The power supply cord or the plug has been damaged.
- Objects have fallen, or liquid has been spilled into the product.
- The product has been exposed to rain.
- The product does not appear to operate normally or exhibits a marked change in performance.
- The product has been dropped, or the enclosure damaged.

**Notes on Repair**

Should an abnormality occur in the product, immediately turn the power OFF, disconnect the power cord plug, and then contact the shop from which the product was purchased.

**CAUTION:**

To prevent electric shock, match wide blade of plug to wide slot, fully insert.

**ATTENTION:**

Pour éviter les chocs électriques, introduire la lame la plus large de la fiche dans la borne correspondante de la prise et pousser jusqu'au fond.



**An information on Disposal for users**

If your product is marked with this recycling symbol it means that, at the end of its life, you must dispose of it separately by taking it to an appropriate collection point. You should not mix it with general household waste. Disposing of this product correctly will prevent potential negative effects on the environment and human health which could otherwise arise due to inappropriate waste handling. For further details, please contact your local authority. (European Union only)

**Instruction for AC power cord (U.K.)**

**IMPORTANT**

THE WIRES IN THIS MAINS LEAD ARE COLOURED IN ACCORDANCE WITH THE FOLLOWING CODE.

- BLUE : NEUTRAL
- BROWN : LIVE

As the colours of the wires in the mains lead of this apparatus may not correspond with the coloured markings identifying the terminals in your plug, proceed as follows:

The wire which is coloured BLUE must be connected to the terminal which is marked with the letter N or coloured BLACK. The wire which is coloured BROWN must be connected to the terminal which is marked with the letter L or coloured RED. Do not plug either terminal of the power cord to the the ground AC outlet on the wall.

**Canadian Radio Interference Regulations**

This instrument complies with the limits for a class B digital apparatus, pursuant to the Radio Interference Regulations, C.R.C., c. 1374.

**FCC Information (U.S.A)**

**CAUTION:** Changes or modifications not expressly approved by the party responsible for compliance could void the user's authority to operate the equipment.

**NOTE:** This equipment has been tested and found to comply with the limits for a Class B digital device, pursuant to Part 15 of the FCC Rules. These limits are designed to provide reasonable protection against harmful interference in a residential installation. This equipment generates, uses and can radiate radio frequency energy and, if not installed and used in accordance with the instructions, may cause harmful interference to radio communications. However, there is no guarantee that interference will not occur in a particular installation. If this equipment does cause harmful interference to radio or television reception, which can be determined by turning the equipment off and on, the user is encouraged to try to correct the interference by one or more of the following measures:

- Reorient or relocate the receiving antenna.
- Increase the separation between the equipment and receiver.
- Connect the equipment into an outlet on a circuit different from that to which the receiver is connected.
- Consult the dealer or an experienced radio/TV technician for help.



**Declaration of Conformity**

Products :	Electronic Piano
Model Number :	ES920
Responsible Party Name :	Kawai America Corporation
Address :	2055 East University Drive Rancho Dominguez, CA 90220
Telephone :	310-631-1771

This device complies with Part 15 of the FCC Rules. Operation is subject to the following two conditions:

- (1) this device may not cause harmful interference, and
- (2) this device must accept any interference received, including interference that may cause undesired operation.

The nameplate label is located on the underside of the instrument, as indicated below.

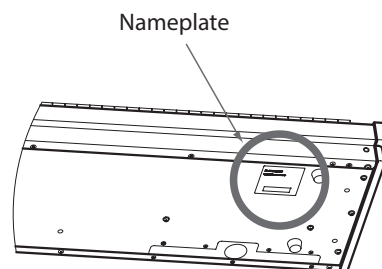

This applies only to products distributed by Kawai America Corporation.

# Displayed Icons



- Bluetooth icon**  
Displayed when Bluetooth Audio or Bluetooth MIDI is on.
- Transpose icon**  
Displayed when key TRANSPOSE is on.
- Headphone icon**  
Displayed when a pair of headphones is connected.
- USB icon**  
Displayed when a USB memory device is connected.
- Panel lock icon**  
Displayed when panel lock is on.

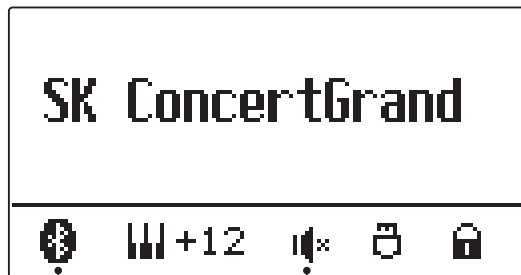

- \* Displayed when the SPEAKER switch is off.**  
(Headphone icon is displayed when a pair of headphones is connected)
- \* Displayed when a Bluetooth connection is made.**

# Table of Contents

## Important Information

Important Safety Instructions .....	3
Displayed Icons .....	7
Table of Contents .....	8
Welcome to the Kawai ES920 .....	10
1. Package Contents .....	10
2. Feature Highlights .....	11
Part Names and Functions .....	12

## Preparation

Setting Up the Piano .....	14
Basic Operation .....	15

## Basic Operation

Selecting Sounds .....	16
Demo Songs .....	17
Dual Mode .....	18
Split Mode .....	20
Four Hands Mode .....	22
Enhancing the Sound .....	24
1. Reverb .....	24
2. Effects .....	26
3. Amp Simulator .....	29
4. Equaliser .....	30
Panel Lock .....	31
Transpose .....	32
Metronome .....	34
Registration Memories .....	36
Rhythm Section Basic Operation .....	38
Rhythm Section Style .....	40
Rhythm Section Parts .....	41
Song Recorder (Internal memory) .....	42
1. Recording a Song .....	42
2. Playing a Song .....	44
3. Recording a Song with the Rhythm Section .....	46
4. Erasing a Part/Song .....	47

Audio Record/Playback (USB memory) .....	48
1. Recording an Audio file .....	48
2. Playing an Audio file .....	50
3. Overdubbing an Audio file .....	52
4. Playing a MIDI file .....	54
5. Converting a MIDI file to an Audio file .....	56
6. Recording an Audio file with the Rhythm Section .....	58
7. Converting a Song to an Audio file .....	59
8. Deleting an Audio/MIDI file .....	60

USB Menu .....	61
1. Load Internal Song .....	62
2. Load Registration .....	63
3. Load Startup Setting .....	64
4. Save SMF Song .....	65
5. Save Internal Song .....	66
6. Save Registration .....	67
7. Save Startup Setting .....	68
8. Rename File .....	69
9. Delete File .....	70
10. Format USB .....	71

## Adjustments & Settings

Settings Menus .....	72
Basic Settings .....	73
1-1. Tone Control .....	74
Brilliance .....	74
User EQ .....	75
1-2. Wall EQ .....	76
1-3. Speaker Volume .....	76
1-4. Low Volume Balance .....	77
1-5. Line Out Volume .....	78
1-6. Audio Recorder Gain .....	78
1-7. Tuning .....	79
1-8. Damper Hold .....	79
1-9. GFP-3 Mode .....	80
1-10. Four Hands .....	81

1-11. Startup Setting .....	82	<b>Rhythm Section Settings</b> .....	113
1-12. Factory Reset .....	83	4-1. Rhythm Volume .....	114
1-13. Auto Display Off .....	84	4-2. Auto Fill-in .....	114
1-14. Auto Power Off .....	85	4-3. One Finger Ad-lib .....	115
<b>Virtual Technician</b> .....	86	4-4. ACC Mode .....	116
2-1. Touch Curve .....	88	4-5. Bass Inversion .....	118
2-2. Voicing .....	90	4-6. Preset Chord .....	119
User Voicing .....	91	<b>Phones Settings</b> .....	120
2-3. Damper Resonance .....	92	5-1. SHS Mode .....	121
2-4. Damper Noise .....	92	5-2. Phones Type .....	122
2-5. String Resonance .....	93	5-3. Phones Volume .....	123
2-6. Undamped String Resonance .....	94	<b>MIDI Settings</b> .....	124
2-7. Cabinet Resonance .....	95	<b>Bluetooth Settings</b> .....	124
2-8. Key-off Effect .....	96	7-1. Bluetooth Audio .....	125
2-9. Fall-back Noise .....	97	7-2. Bluetooth Audio Volume .....	126
2-10. Hammer Noise .....	97	7-3. Bluetooth MIDI .....	127
2-11. Hammer Delay .....	98	<b>Appendix</b>	
2-12. Topboard .....	99	<b>Connecting to Other Devices</b> .....	128
2-13. Decay Time .....	100	Rear Connectors .....	129
2-14. Release Time .....	100	Upper Connectors .....	129
2-15. Minimum Touch .....	101	Front Connectors .....	129
2-16. Temperament .....	102	<b>USB MIDI (USB to Host Connector)</b> .....	130
Stretch Tuning .....	103	<b>Information about Bluetooth®</b> .....	131
Stretch Curve .....	104	<b>Troubleshooting</b> .....	132
User Tuning .....	104	<b>Demo Song List</b> .....	133
Temperament Key .....	105	<b>Rhythm Section Style List</b> .....	134
User Temperament .....	105	<b>Rhythm Section Chord Types</b> .....	135
2-17. User Key Volume .....	106	<b>Rhythm Section Preset Chord Sequences</b> .....	139
2-18. Half-Pedal Adjust .....	107	<b>EU Declaration of Conformity</b> .....	141
2-19. Soft Pedal Depth .....	107	<b>Kawai ES920 Specifications</b> .....	142
<b>Key Settings</b> .....	108	<b>Owner's Manual Conventions</b> .....	143
3-1. Lower Octave Shift .....	109		
3-2. Lower Pedal .....	110		
3-3. Split Balance .....	110		
3-4. Layer Octave Shift .....	111		
3-5. Layer Dynamics .....	112		
3-6. Dual Balance .....	112		

# Welcome to the Kawai ES920

Thank you for purchasing this Kawai ES920 digital piano.

This owner's manual contains important information regarding the usage and operation of the ES920 digital piano.

Please read all sections carefully, keeping this manual handy for future reference.

## 1 Package Contents

The Kawai ES920 digital piano package contains the following items:

### ■ ES920 digital piano

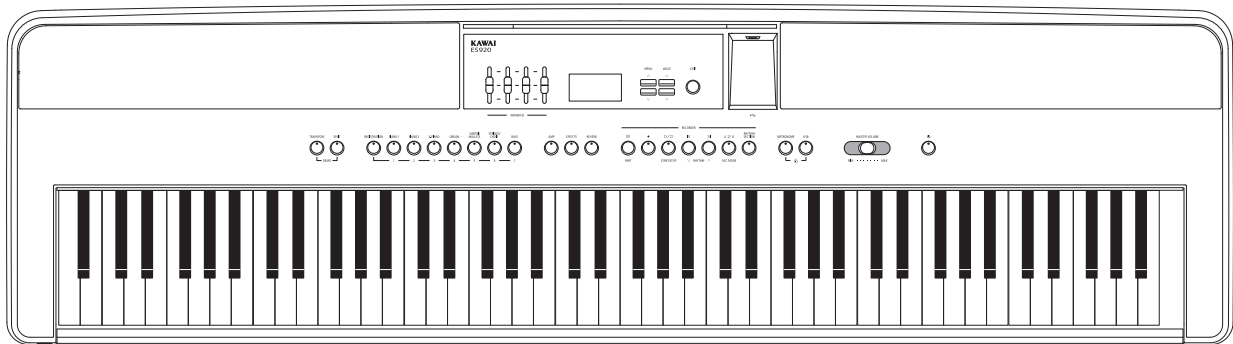

### ■ AC power adaptor (PS-154)

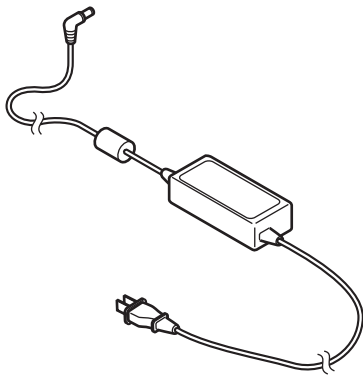

### ■ Foot pedal (F-10H)

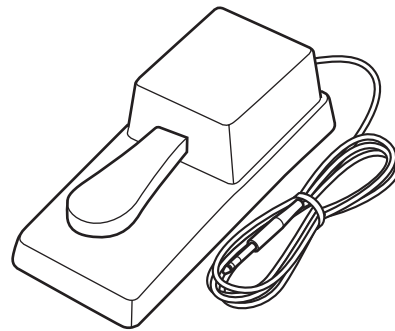

### ■ Music rack/rest

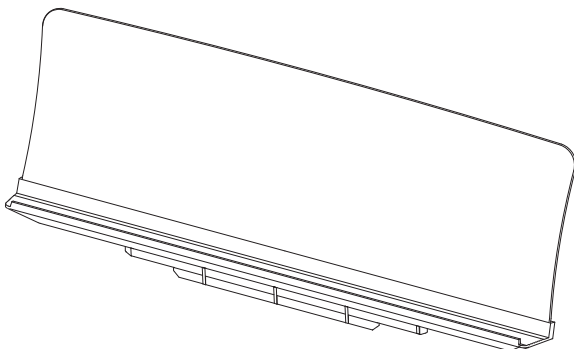

### ■ Owner's manual

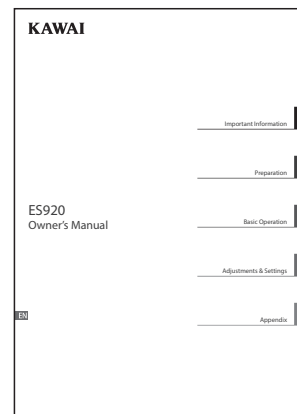

## 2 Feature Highlights

### **“Responsive Hammer III” weighted-key action, with Ivory Touch key surfaces and Let-off simulation**

The new *Responsive Hammer III (RHIII)* action recreates the distinctive touch of an acoustic grand piano, with its realistic movement and accurate 3-sensor technology providing a smooth, natural, and highly responsive piano playing experience. The weight of the keyboard is appropriately graded to mirror the heavier bass hammers and lighter treble hammers of an acoustic piano, while structural reinforcements within the action assembly ensure greater stability during fortissimo and staccato passages.

The ES920 digital piano also features Kawai’s *Ivory Touch* key surfaces that gently absorb finger moisture to assist the player’s performance, while, *let-off* simulation recreates the subtle “notch” sensation felt when softly playing the keys of a grand piano, satisfying the expectations of the most discerning pianists.

### **Shigeru Kawai SK-EX, SK-5, and Kawai EX instruments reproduced with Harmonic Imaging sound technology**

The ES920 digital piano captures the rich, expressive sound of the Kawai SK-EX, SK-5, and EX grand pianos, with all 88 keys of these exceptional instruments meticulously recorded, analysed and faithfully reproduced using *Harmonic Imaging™* sound technology. This unique process accurately recreates the broad dynamic range of the original grand pianos, affording pianists an extraordinary level of expressiveness ranging from the softest pianissimo to the strongest, boldest fortissimo.

The instrument’s built-in *Virtual Technician* feature allows various characteristics of these acoustic piano sounds to be shaped at the touch of a button, with settings to adjust string and damper resonance, in addition to subtle hammer, damper, and key release noises. This personalised piano sound is further enhanced with atmospheric reverberation effects, delivering a rich, vibrant piano tone with breathtaking realism and authenticity.

### **Strong selection of additional instrument sounds**

Supplementing the realistic acoustic piano voices, the ES920 digital piano also features a strong selection of additional instrument sounds, ranging from electric pianos and drawbar and church organs, to string, choir, and mallet instruments, inviting musicians to add greater variety to their performances.

Furthermore, the *Dual* playing mode also allows two different sounds, such as grand piano and strings, to be layered together, while the *Split* and *Four Hands* modes divide the keyboard into two independent sections. The volume balances for each playing mode can also be adjusted quickly and easily using the real-time panel controls.

### **USB to Device functionality, with MP3/WAV file recording and playback**

The ES920 digital piano is equipped with USB connectors that not only allow the instrument to be connected to a computer for MIDI use, but also to load and save data to USB memory devices directly. This *USB to Device* feature allows registration memories and songs recorded and stored in internal memory to be saved to USB for posterity, or standard MIDI files (SMF) downloaded from the internet to be conveniently played back without additional hardware.

USB memory devices can also be used to play back MP3 or WAV audio files, allowing musicians to learn the chords or melody for a new piece, or to simply play along with their favourite songs. It is even possible to save performances as MP3 or WAV files for emailing to friends and family, listening to on a smartphone, or for further editing using an audio workstation.

### **Wide range of connectivity options**

The ES920 digital piano features a variety of standard connectivity options, with Line-level output jacks that allow the instrument to be enjoyed in larger settings such as churches and schools. Standard MIDI and *USB to Host* connectors ensure flexibility when using computers and other electronic instruments, while the Line-in stereo jack provides a convenient method of mixing in audio from a laptop, tablet, or other digital device.

### **Integrated Bluetooth® MIDI connectivity**

In addition to standard MIDI jacks for connecting to other instruments, the ES920 digital piano also boasts integrated Bluetooth MIDI and Audio technology that allows the instrument to communicate with supported smart devices wirelessly. Once connected to a phone, tablet, or laptop, ES920 digital piano owners can enjoy a wide variety of exciting music-related apps that enhance their learning and playing experience, or stream audio from songs and videos through the instrument’s speakers without additional cables.

\* Availability of Bluetooth function dependent on market location.

# Part Names and Functions

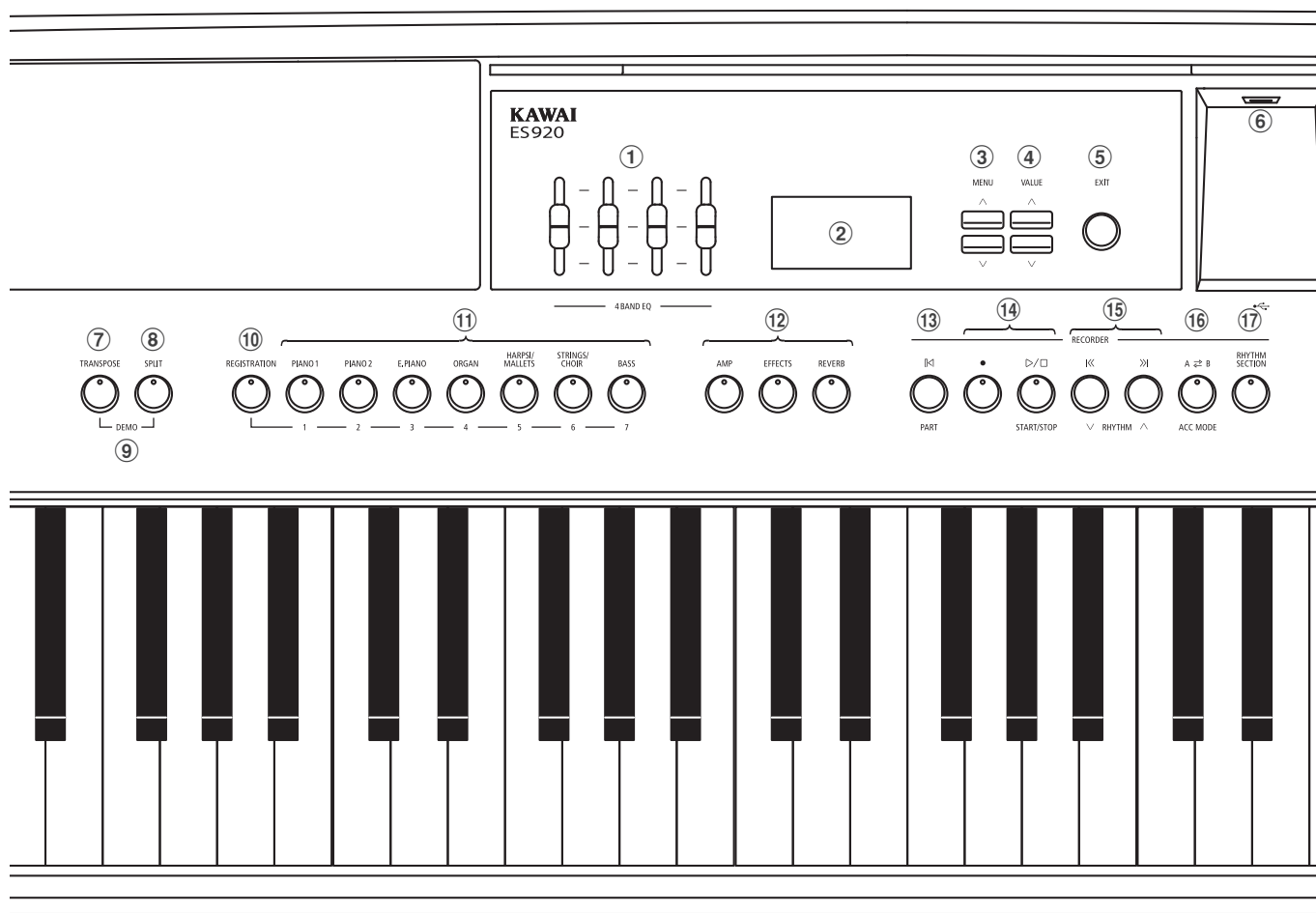

## ① 4-band equaliser

The equaliser is used to adjust the volume of the low, mid-low, mid-high, and high frequency bands.

## ② Display

The display provides important information relating to the currently selected sound, style, function, and setting.

\* A protective plastic film is attached to the display during production. Please remove this film before attempting to play the instrument.

## ③ MENU buttons

These buttons are used to navigate through the instrument's various function and settings menus.

## ④ VALUE buttons

These buttons are used to adjust values, and change settings etc.

## ⑤ EXIT button

This button is used to exit the current function, or return to the previous screen.

## ⑥ USB to Device port (Type A)

This port is used to connect a FAT or FAT32 formatted USB memory device to the instrument in order to load/save recorded song data, registration memories, and MP3/WAV/SMF files etc.

\* Use this port for connecting USB memory devices only.

\* Connect the USB memory device directly, without using a USB extension cable.

## ⑦ TRANSPOSE button

This button is used to adjust the pitch of the instrument's keyboard in semi-tone steps.

## ⑧ SPLIT button

This button is used to select and adjust the instrument's Split/Four Hands mode functions.

## ⑨ DEMO button

When pressed simultaneously, the TRANSPOSE and SPLIT buttons are also used to select the instrument's Demo mode.

## ⑩ REGISTRATION button

This button is used to store and recall one of the 28 different Registration memories. Each Registration can store sound, Rhythm Section, reverb/effects, and Virtual Technician settings, as well as various other panel and menu options.

## ⑪ SOUND buttons

These buttons are used to select the sound(s) that will be heard when playing the instrument's keyboard.

These buttons are also used to select Registration memories.

## ⑫ AMP/EFFECTS/REVERB buttons

These buttons are used to turn the instrument's amp, reverb, and effects functions on/off, and to adjust their various settings.

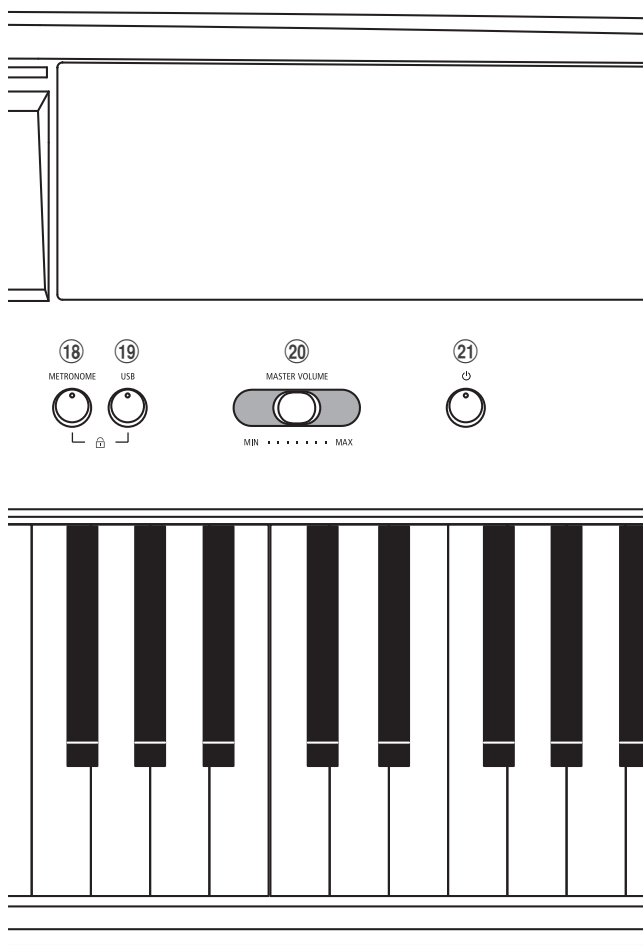

### 13 (RESET/PART) button

This button is used to reset the instrument's song recorder, and to rewind songs and MP3/WAV/SMF files to the beginning.

This button is also used to select the Rhythm Section part.

### 14 (REC) and (PLAYBACK / START/STOP) buttons

These buttons are used to record and playback songs stored in the instrument's internal memory, or MP3/WAV/SMF files saved to a USB memory device.

### 15 (REW) and (FWD) buttons

These buttons are used to move the playing position of the current recorder song or MP3/WAV/SMF backward or forward.

These buttons are also used to select the recorder song and Rhythm Section style.

### 16 A B (LOOP) button

This button is used to enable the instrument's A-B Loop function, allowing passages of a recorder song or MP3/WAV/SMF file to be played back repeatedly.

This button is also used to select the Rhythm Section ACC mode.

### 17 RHYTHM SECTION button

This button is used to select the instrument's Rhythm Section function, featuring drum rhythms and accompaniment styles.

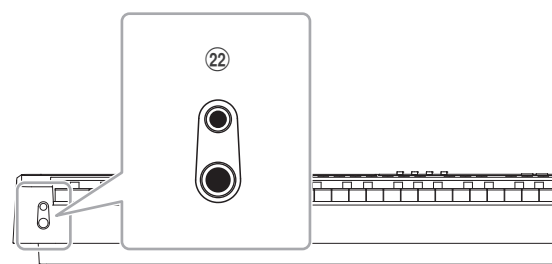

### 18 METRONOME button

This button is used to turn the instrument's metronome function on/off, and to adjust metronome settings.

### 19 USB button

This button is used to access the instrument's USB functions.

When pressed simultaneously, the METRONOME and USB buttons are used to toggle the instrument's Panel Lock feature.

### 20 MASTER VOLUME slider

This slider controls the master volume level of the instrument's built-in speakers or headphones, if connected.

\* This slider affects the LINE OUT level. For information about adjusting the LINE OUT level, please refer to page 78.

### 21 POWER button

This button is used to turn the instrument on and off. Be sure to turn off the instrument after use.

\* The ES920 digital piano features a power saving mode that can turn off the instrument automatically after a specified period of inactivity. For more information, please refer to the Auto Power Off setting on page 85.

### 22 PHONES jacks

These jacks are used to connect stereo headphones to the instrument. Two pairs of headphones can be connected and used simultaneously.

\* For more information about connectors/jacks, please refer to page 128.

# Setting Up the Piano

Upon unboxing the instrument, please follow the instructions below which explain how to attach the music rest, connect the F-10H (or optional GFP-3) foot pedal, and if desired, connect a pair of headphones.

## ■ Attaching the music rest

Insert the base of the music rest into the groove located at the rear of the ES920 digital piano, taking care not to scratch the rear of the instrument.

To prevent possible damage, avoid applying excessive force when attaching/detaching the music rest from the instrument.

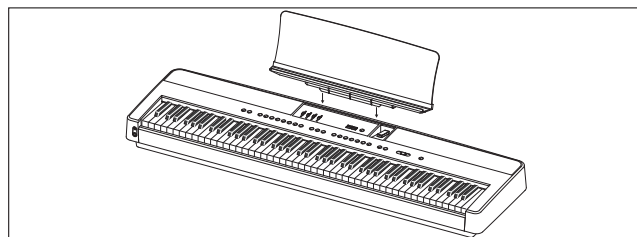

## ■ Connecting the F-10H foot pedal

Connect the included Kawai F-10H foot pedal to the DAMPER pedal jack located on the rear panel of the instrument.

The foot pedal will function as a damper pedal, sustaining the sound after hands are lifted from the keyboard. This pedal is capable of responding to “half pedaling”.

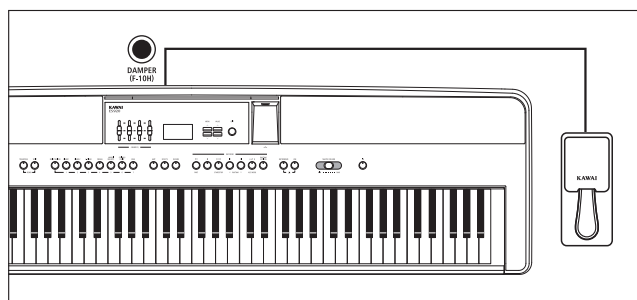

## ■ Connecting the optional GFP-3 triple pedal

Connect the optional Kawai GFP-3 triple pedal to the DAMPER/SOFT pedal jack located on the rear panel of the instrument.

The right pedal will function as a damper pedal, sustaining the sound after hands are lifted from the keyboard. This pedal is also capable of responding to “half pedaling”.

The centre pedal will function as a sostenuto pedal, and the left pedal will function as a soft pedal.

\* When “Jazz Organ”, “Drawbar Organ” or “Ballad Organ” sounds are selected, the soft pedal can also be used to alternate the speed of the rotary speaker effect between “Slow” and “Fast” modes.

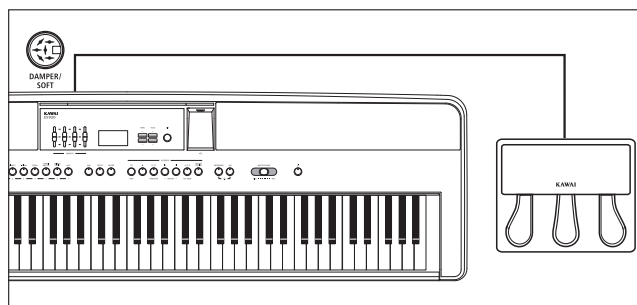

## ■ Connecting headphones

Use the jacks located on either side of the keyboard to connect stereo headphones to the ES920 digital piano.

There are one standard jack and one mini jack so up to two pairs of headphones can be connected. When a pair of headphones is connected, sound will not be produced by the built-in speakers.

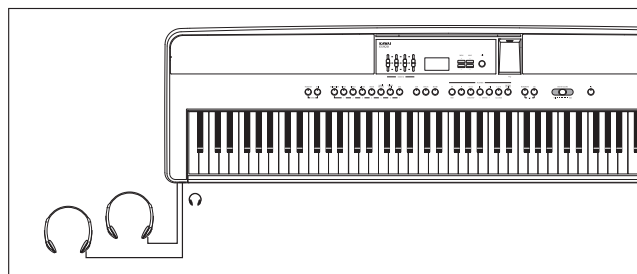

## ■ Turning built-in speakers on/off

Set the SPEAKER switch located on the rear panel to the Off position to disable the instrument’s built-in speakers. Set the switch to the On position to enable the speakers.

\* When a pair of headphones is connected, sound will not be produced from the built-in speakers regardless of the status of the SPEAKER switch.

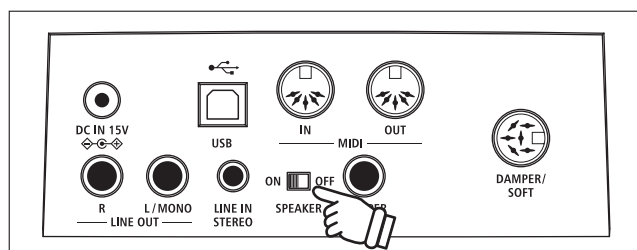

# Basic Operation

The following instructions explain how to connect the instrument to the power outlet, turn on the power, adjust the volume to a comfortable level, and begin playing the piano.

## 1. Connecting the power adaptor

Connect the included AC power adaptor to the "DC IN" jack located on the rear panel of the instrument, indicated below.

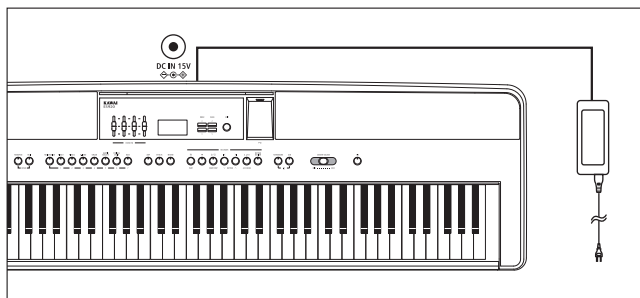

Connect the AC power adaptor to an AC outlet.

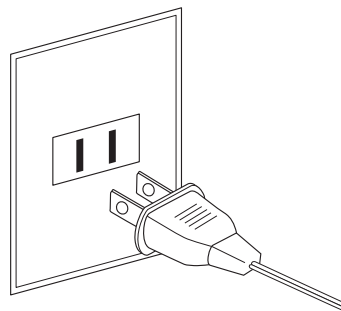

## 2. Turning on the instrument's power

Press the POWER button located on the right side of the instrument's control panel.

The instrument will turn on, and the words "SK ConcertGrand" will be shown in the display, indicating that the SK ConcertGrand sound is selected. The LED indicator for the PIANO 1 button will also turn on.



**LED indicator on:**  
Sound category is selected.

\* The ES920 digital piano features a power saving mode that can turn off the instrument automatically after a specified period of inactivity. For more information, please refer to the Auto Power Off setting on page 85.

## 3. Adjusting the volume

The MASTER VOLUME slider controls the volume level of the instrument's speakers, or headphones if connected.

Move the slider to the right to increase the volume, and to the left to decrease the volume.

Use this slider to set the volume to a comfortable listening level - the middle is often a good starting point.

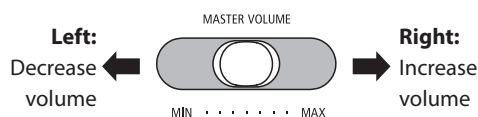

\* This slider affects the LINE OUT level. For information about adjusting the LINE OUT level, please refer to page 78.

## 4. Play the piano

Begin playing the piano.

The rich sound of a Kawai SK-EX Concert Grand Piano will be heard as the keys are pressed.

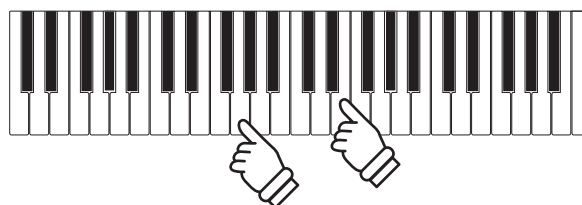

# Selecting Sounds

The ES920 digital piano features a wide selection of realistic instrument sounds suitable for various musical styles. Sounds are arranged into seven categories, with multiple sounds assigned to each category button.

By default, the “SK ConcertGrand” sound will be selected automatically when the instrument is turned on.

## ■ Sound categories and variations

PIANO 1		PIANO 2		E. PIANO		ORGAN	
1	SK ConcertGrand	1	SK-5 GrandPiano	1	Classic E.Piano	1	Jazz Organ
2	EX ConcertGrand	2	Upright Piano	2	Classic E.P. 2	2	Drawbar Organ
3	Jazz Clean	3	Pop Grand 2	3	Classic E.P. 3	3	Ballad Organ
4	Warm Grand	4	Modern Piano	4	60's E.Piano	4	Principal Oct.
5	Pop Grand	5	Rock Piano	5	60's E.Piano 2	5	Church Organ
				6	Modern E.Piano		

  

HARPSI / MALLETS		STRINGS / CHOIR		BASS			
1	Harpichord	1	String Ensemble	5	Choir Ooh/Aah	1	Electric Bass
2	Vibraphone	2	Slow Strings	6	Pop Ensemble	2	Electric Bass 2
3	Clavi	3	String Pad	7	Square Pad	3	Electric Bass 3
4	Marimba	4	Warm Strings	8	New Age Pad	4	Wood Bass
						5	W. Bass & Ride

### 1. Selecting a sound category

Press the desired SOUND button.

The LED indicator for the button will turn on to indicate that this category has been selected, and the name of the sound will be shown in the display.

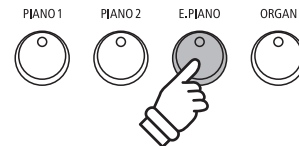

**Example:** To select the E.PIANO category, press the E.PIANO button.

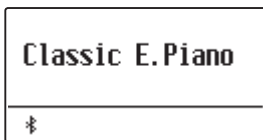

### 2. Changing the selected sound variation

Several sound variations are assigned to each category button.

Press a SOUND button repeatedly to cycle through the different sound variations.

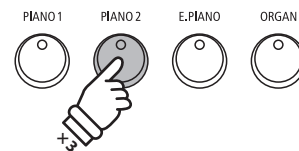

**Example:** To select the “Pop Grand 2” sound, press the PIANO2 button three times.

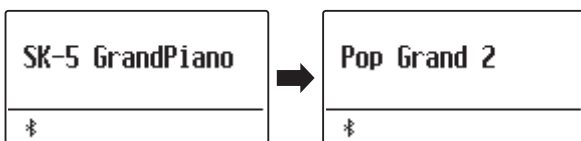

The ∨ or ∧ VALUE buttons can also be used to select sounds, and cycle through the different sound variations.

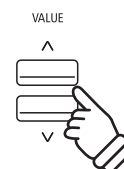

# Demo Songs

The Demo function provides an excellent introduction to the varied capabilities of the ES920 digital piano. There are 25 different demonstration songs available, highlighting the instrument's rich selection of high quality sounds, convenient Rhythm Section feature, and powerful speaker system.

For a complete listing of the available demonstration songs, please refer to page 133 of this owner's manual.

\* Kawai regrets that sheet music for Kawai original demo songs is not available.

## 1. Entering demo mode

Press the TRANSPOSE and SPLIT buttons simultaneously.

The LED indicators for both buttons will start to flash to indicate that demo mode is in use, and the Main Demo song will start to play.

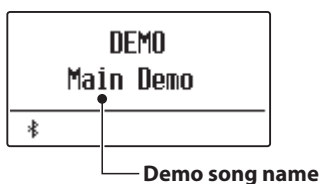
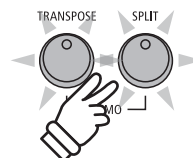

\* When the Main Demo song has finished, a sound demo song will be selected at random, and will start to play.

\* During demo mode, pedals connected to the ES920 will not be effective.

## 2. Selecting a demo song

While Demo mode is selected and the demo songs are playing:

Press the desired SOUND button.

The LED indicator for the button will start to flash, and the first demo in the selected sound category will start to play.

Press the selected sound category button repeatedly to cycle through the different demo songs in that category.

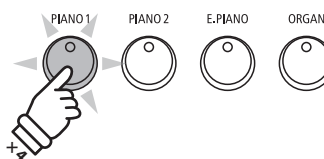

**Example:** To select the Warm Grand demo song, press the PIANO1 button four times.



In addition, press the RHYTHM SECTION button to play the Rhythm Section demo song.

\* When the Rhythm Section song has finished, the Main Demo song will be re-selected, and will start to play.

The √ or ^ VALUE buttons can also be used to cycle through all of the different demo songs.

The √ or ^ MENU buttons can be used to switch for each group.

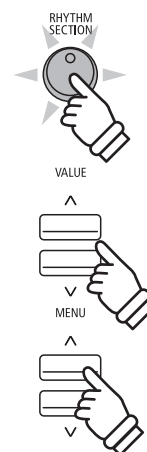

## 3. Stopping the demo song and exiting demo mode

While Demo mode is selected and the demo songs are playing:

Press the EXIT button.

The LED indicators will stop flashing, the demo songs will stop playing, and the instrument will return to normal playing mode.

EXIT



# Dual Mode

The Dual Mode function allows two sounds to be layered together, creating a more complex sound. For example, a piano sound layered with strings, or a church organ combined with a choir, etc.

## 1. Entering Dual mode

Press and hold a SOUND button to select the main sound, then press another SOUND button to select the layered sound.

The LED indicators for both SOUND buttons will turn on to indicate that Dual mode is in use, and the respective sound names will be shown in the display.

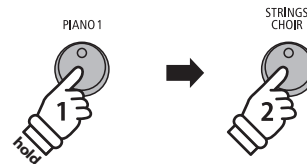
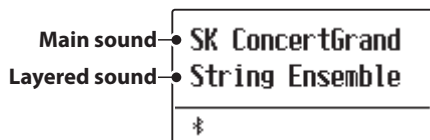

**Example:** To layer the "Slow Strings" sound with the "SK ConcertGrand" sound, press and hold the PIANO1 button, then press the STRINGS/CHOIR button.

## 2. Changing the main/layered sounds

To select a different variation for the layered sound:

Press and hold the main SOUND button, then press the layered SOUND button repeatedly to cycle through the different sound variations.

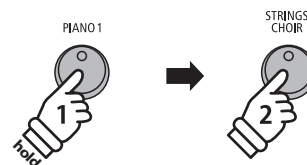
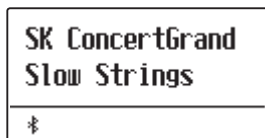

**Example:** To change the layered "String Ensemble" sound to the "Slow Strings" sound, press and hold the PIANO1 button, then press the STRINGS/CHOIR button.

To select a different variation for the main sound:

Press and hold the layered SOUND button, then press the main SOUND button repeatedly to cycle through the different sound variations.

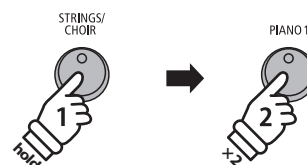
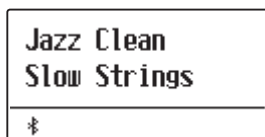

**Example:** To change the main "SK ConcertGrand" sound to the "Jazz Clean" sound, press and hold the STRINGS/CHOIR button, then press the PIANO1 button twice.

To layer two variations assigned to the same SOUND button:

Press and hold a SOUND button, then press the  $\vee$  or  $\wedge$  VALUE buttons to select the layered sound variation.

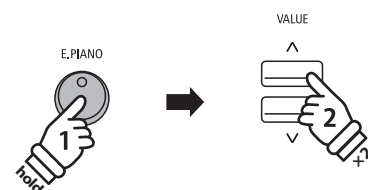
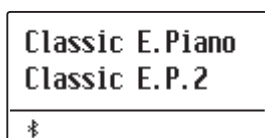

**Example:** To layer the "Classic E.P." and "60's E.Piano" sounds together, press and hold the E.PIANO button, then press the VALUE  $\wedge$  button twice.

\* Preferred Dual mode sound combinations can be stored to a Registration memory for convenient recall. Please refer to page 36 for more information.

### 3. Adjusting the main/layered sound volume balance

While Dual mode is in use:

Press the  $\nabla$  or  $\wedge$  VALUE buttons to adjust the volume balance between the main and layered sounds.

The volume balance will briefly be shown in the display.

\* The default Dual mode volume balance is 9-9.

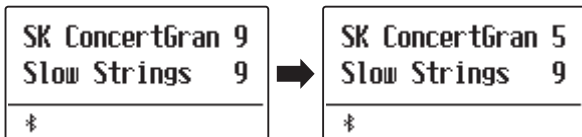

\* The preferred Dual mode volume balance can also be stored to a Registration memory for convenient recall. Please refer to page 36 for more information.

\* The Layer Octave Shift setting can be used to adjust the octave range of the layered sound. Please refer to page 111 for more information.

\* The Layer Dynamics setting can be used to adjust the dynamic sensitivity of the layered sound. Please refer to page 112 for more information.

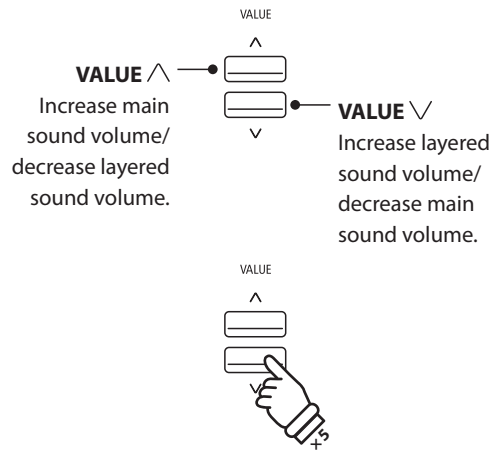

**Example:** To decrease the volume of the main sound to 5, press the VALUE  $\nabla$  button five times.

### 4. Exiting Dual mode

While Dual mode is in use:

Press a single SOUND button.

The LED indicator for the button will turn on, the name of the selected sound will be shown in the display, and the instrument will return to normal (single voice mode) operation.

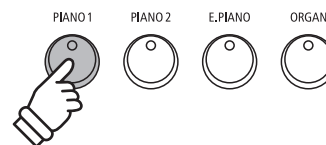

# Split Mode

The Split Mode function divides the keyboard into two sections, allowing each section to be played with a different sound. For example, a bass sound in the lower section, and a piano sound in the upper section.

## 1. Entering Split mode

Press the SPLIT button.

The LED indicator for the SPLIT button will turn on and the keyboard is split at the point between F#3 and G3. G3 where the upper section begins, is called the split point.

The default split point is G3.

The LED indicator for the upper section sound button will turn on, and the LED indicator for the lower section sound button will start to flash. The respective sound names will also be shown in the display.

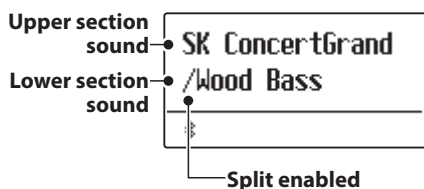
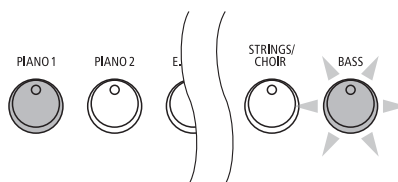

### Default Split mode:

The previously selected sound is used for the upper section, and the "Wood Bass" sound is selected for the lower section.

## 2. Changing the upper/lower section sounds

To select a different sound for the upper section:

Press the desired SOUND button.

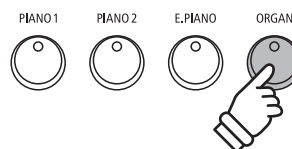
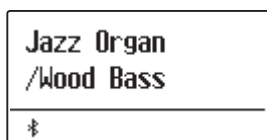

**Example:** To select the "Jazz Organ" sound for the upper section, press the ORGAN button.

To select a different sound for the lower section:

Press and hold the SPLIT button, then press the desired SOUND button.

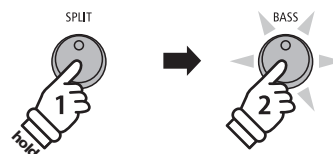
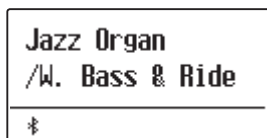

**Example:** To select the "W. Bass & Ride" sound for the lower section, press and hold the SPLIT button, then press the BASS button.

\* The Lower Octave Shift setting can be used to adjust the octave range of the lower section. Please refer to page 109 for more information.

\* The Lower Pedal setting can be used to enable/disable the damper pedal for the lower section. Please refer to page 110 for more information.

\* Preferred Split mode upper/lower sound combinations can be stored to a Registration memory for convenient recall. Please refer to page 36 for more information.

### 3. Changing the split point

Press and hold the SPLIT button, then press the desired split key on the keyboard.

The name of the pressed key will briefly be shown in the display, and will become the new split point.

\* Split Mode and the Rhythm Section share the same split point.

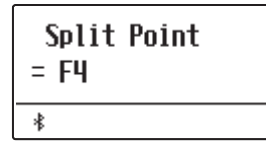

*Example: To set the split point to key F4, press and hold the SPLIT button, then press the F4 key.*

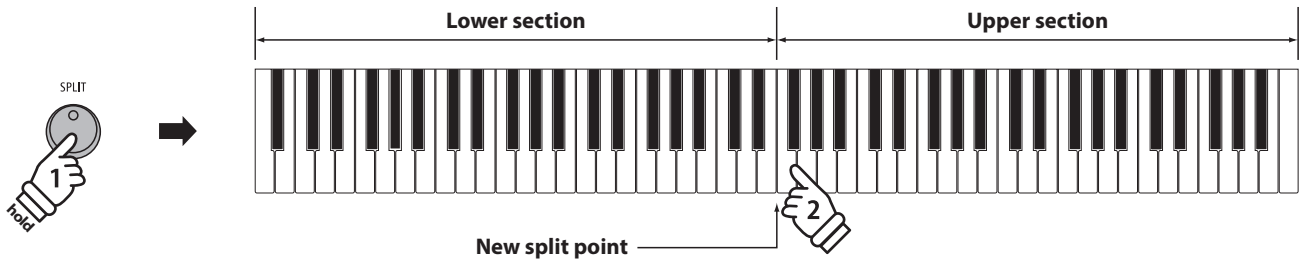

### 4. Adjusting the upper/lower sound volume balance

While Split mode is in use:

Press the  $\nabla$  or  $\wedge$  VALUE buttons to adjust the volume balance between the upper and lower sections.

The volume balance will briefly be shown in the display.

\* The default Split mode volume balance is 9-9.

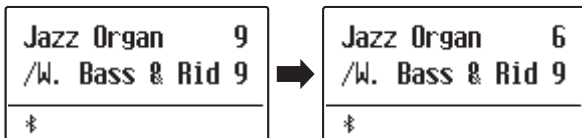

\* The preferred Split mode upper/lower volume balance can also be stored to a Registration memory for convenient recall. Please refer to page 36 for more information.

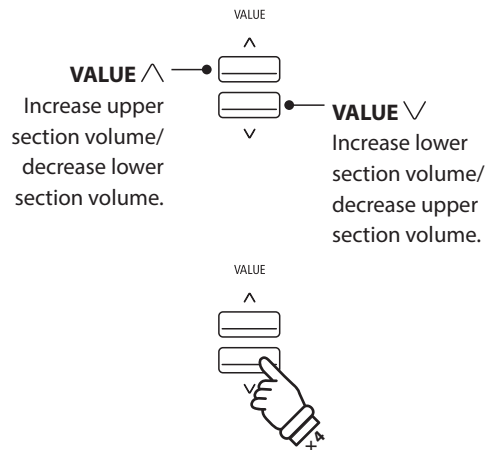

*Example: To decrease the volume of the upper section sound to 6, press the VALUE  $\nabla$  button four times.*

### 5. Exiting Split mode

While Split mode is in use:

Press the SPLIT button.

The LED indicator for the SPLIT button will turn off, and the instrument will return to normal (full keyboard) operation.

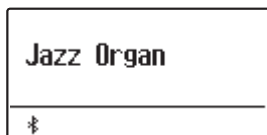

# Four Hands Mode

The Four Hands Mode function divides the keyboard into two sections in a similar way to that of the Split Mode function. However, with Four Hands Mode enabled, the octave/pitch of each section is automatically adjusted to create two separate 44-key instruments with the same playing range. This function is intended to allow two people to practise together or perform piano duets using a single instrument.

## 1. Entering Four Hands mode

Press and hold the SPLIT button, then press the damper pedal.

The LED indicator for the SPLIT button will start to flash to indicate that Four Hands mode is in use.

\* The default four hands mode split point is set between keys E4 and F4.

The LED indicator for the PIANO1 button will turn on, and the "SK ConcertGrand" sound will automatically be selected for both the upper and lower sections.

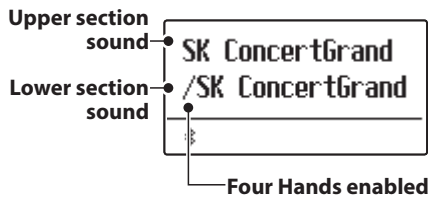
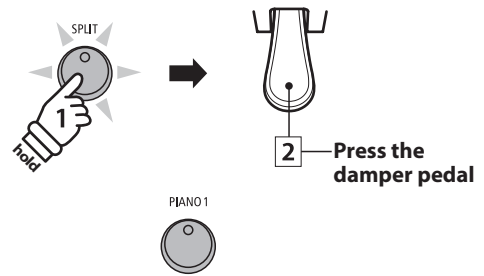

**Default Four Hands mode:**  
The "SK ConcertGrand" sound is selected for both the upper and lower sections.

## 2. Changing the upper/lower section sounds

To select a different sound for the upper section:

Press the desired SOUND button.

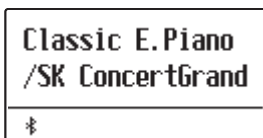
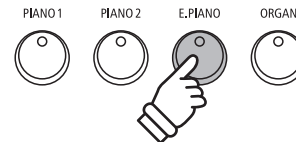

**Example:** To select the "Classic E.P." sound for the upper section, press the E.PIANO button.

To select a different sound for the lower section:

Press and hold the SPLIT button, then press the desired SOUND button.

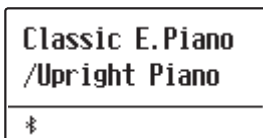
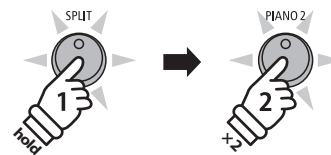

**Example:** To select the "Upright Piano" sound for the lower section, press and hold the SPLIT button, then press the PIANO2 button twice.

\* If the included F-10H foot pedal is connected to the instrument, the pedal will function as a damper pedal for the upper section only. However, if the optional GFP-3 or F-302 triple pedal is connected, the right (sustain) and left (soft) pedals will function as independent damper pedals for the upper and lower sections respectively.

\* Preferred Four Hands mode upper/lower sound combinations can be stored to a Registration memory for convenient recall. Please refer to page 36 for more information.

### 3. Changing the Four Hands mode split point

Press and hold the SPLIT button, then press the desired split key on the keyboard.

The name of the pressed key will briefly be shown in the display, and will become the new Four Hands mode split point.

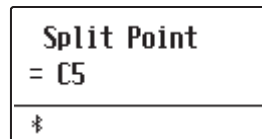

*Example:* To set the split point to key C5, press and hold the SPLIT button, then press the C5 key.

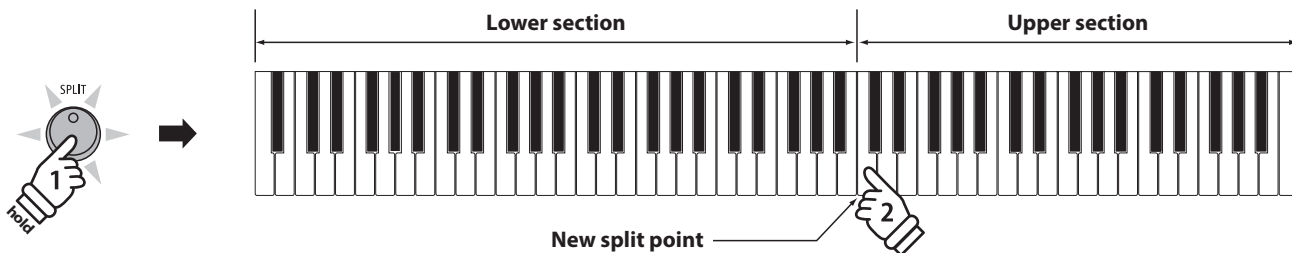

### 4. Adjusting the upper/lower sound volume balance

While Four Hands mode is in use:

Press the  $\nabla$  or  $\blacktriangle$  VALUE buttons to adjust the volume balance between the upper and lower sections.

The volume balance will briefly be shown in the display.

\* The default Four Hands mode volume balance is 9-9.

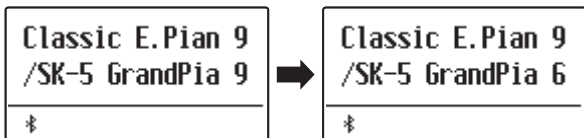
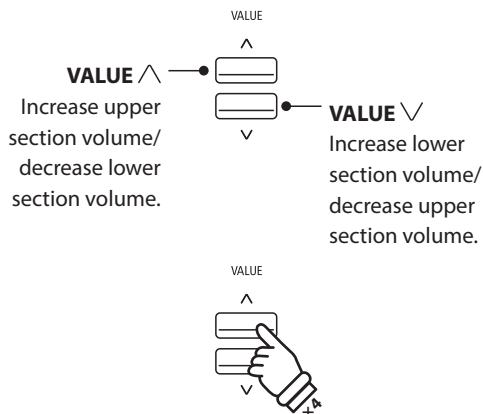

\* The preferred Four Hands mode upper/lower volume balance can also be stored to a Registration memory for convenient recall. Please refer to page 36 for more information.

*Example:* To decrease the volume of the lower section sound to 6, press the VALUE  $\blacktriangle$  button four times.

### 5. Exiting Four Hands mode

While Four Hands mode is in use:

Press the SPLIT button.

The LED indicator for the SPLIT button will stop flashing, and the instrument will return to normal (full keyboard) operation.

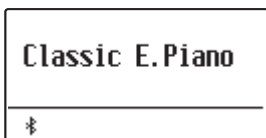

# Enhancing the Sound

The ES920 digital piano offers a variety of features to adjust and enhance the character of a particular sound. Some of these features (e.g. Reverb), are enabled automatically when a sound is selected, however players may also wish to change the strength or type of enhancement to suit their personal preferences or different styles of music.

## 1 Reverb

Reverb adds reverberation to the sound, simulating the acoustic environment of a recital room, stage, or concert hall. Some sound types, such as acoustic piano, enable reverb automatically in order to improve acoustic realism. The ES920 digital piano features six different reverb types.

### ■ Reverb types

Reverb type	Description
Room	Simulates the ambience of a small rehearsal room.
Lounge	Simulates the ambience of piano lounge.
Small Hall	Simulates the ambience of a small hall.
Concert Hall	Simulates the ambience of a concert hall or theater.
Live Hall	Simulates the ambience of a live hall or stage.
Cathedral	Simulates the ambience of a large cathedral.

### 1. Turning Reverb on/off

Press the REVERB button to turn reverb on/off.

The LED indicator for the REVERB button will turn on to indicate when reverb is in use, and the current status will briefly be shown in the display.

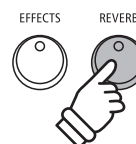

### 2. Entering the Reverb settings menu

Press and hold the REVERB button.

The reverb settings menu will be shown in the display.

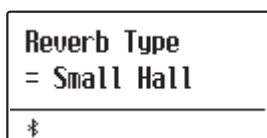
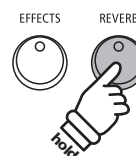

### ■ Reverb settings

Reverb setting	Description	Range
Type	Changes the type of environment.	–
Depth	Adjusts the depth of the environment (i.e. amount of reverberation to apply).	1~10
Time	Adjusts the decay length/speed of the reverberation.	1~10

### 3. Adjusting the Reverb settings (type/depth/time)

While the reverb settings menu is shown, to change the reverb type:

Press the  $\nabla$  or  $\wedge$  VALUE buttons to cycle through the different reverb types.

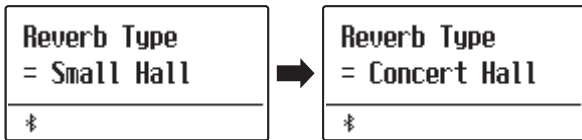

**Example:** To change the reverb type from “Small Hall” to “Concert Hall”, press the VALUE  $\wedge$  button.

To change the reverb depth:

Press the  $\nabla$  or  $\wedge$  MENU buttons to select the “Reverb Depth” page, then press the  $\nabla$  or  $\wedge$  VALUE buttons to decrease or increase the reverb depth setting.

\* The reverb depth setting can be adjusted within the range of 1~10.

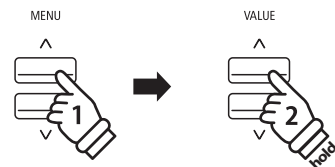
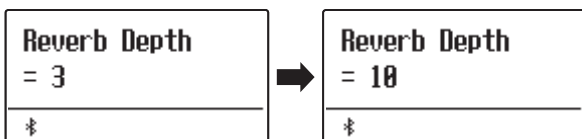

**Example:** To increase the reverb depth, press the MENU  $\wedge$  button to select the “Reverb Depth” page, then press and hold the VALUE  $\wedge$  button.

To change the reverb time:

Press the  $\nabla$  or  $\wedge$  MENU buttons to select the “Reverb Time” page, then press the  $\nabla$  or  $\wedge$  VALUE buttons to decrease or increase the reverb time setting.

\* The reverb time setting can be adjusted within the range of 1~10.

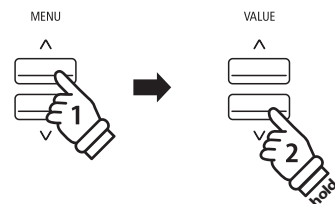
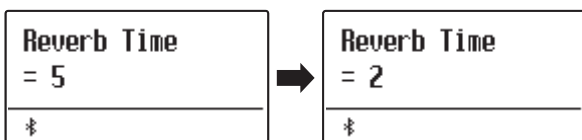

**Example:** To reduce the reverb time, press the MENU  $\wedge$  button to select the “Reverb Time” page, then press and hold the VALUE  $\nabla$  button.

To exit the reverb settings menu and return to normal playing mode, press the EXIT button or wait 10 seconds.



- \* Reverb settings are independent for each sound variation.
- \* Any changes made to the reverb type, settings, or on/off status will remain until the power is turned off.
- \* Preferred reverb settings can be stored to a Registration memory for convenient recall. Please refer to page 36 for more information.

## 2 Effects

In addition to reverb, various other effects can be applied to the selected sound, altering the tonal character and feeling of the instrument. As with reverb, some sound types enable certain effects automatically in order to enhance tonal quality. The ES920 digital piano features 16 different effect types.

### ■ Effect types

Effect type	Description
Mono Delay	Adds an echo effect to the sound, playing through both speakers (stereo) simultaneously.
Ping Delay	Adds a "ping pong" echo effect to the sound, giving the impression that it is "bouncing" from left to right.
Triple Delay	Similar in principle to Ping Delay, but with an additional centre echo.
Chorus	Layers a slightly detuned version of the sound over the original, thus enriching its tonal character.
Classic Chorus	Similar in principle to Chorus, but intended for vintage electric piano sounds.
Ensemble	Enriches the sound by adding three voiced chorus.
Tremolo	Adds a tremor to the sound by varying the volume constantly.
Classic Tremolo	Similar in principle to Tremolo, but intended for vintage electric piano sounds.
Vibrato Tremolo	Adds vibrato to tremolo.
Auto Pan	Alternates the sound output from left to right across the stereo field using a sine wave.
Classic Auto Pan	Similar in principle to Auto Pan, but intended for vintage electric piano sounds.
Phaser	Applies a cyclic phase change to the sound, giving the impression that the sound is moving.
Classic Phaser	Adds an effect produced by digital signal processing of classic chorus.
Compressor	Increases the acoustic pressure.
Rotary 1	Simulates the sound of a rotary speaker commonly used with vintage electronic organs. * Pressing the ∨ and ∧ MENU buttons simultaneously alternates the speed of the rotary simulation between "Slow" and "Fast" effect modes. If the optional GFP-3 or F-302 pedal is connected, the left (soft) pedal can also be used.
Rotary2	Adds vibrato to the rotary speaker effect.

### 1. Turning Effects on/off

Press the EFFECTS button to turn effects on/off.

The LED indicator for the EFFECTS button will turn on to indicate when effects are in use, and the current status will briefly be shown in the display.

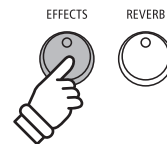

## 2. Entering the Effects settings menu, selecting the Effect type

Press and hold the EFFECTS button.

The first page of the effects settings menu will be shown in the display.

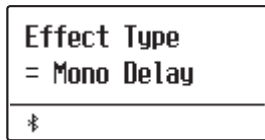

Press the  $\nabla$  or  $\blacktriangle$  VALUE buttons to cycle through the different effect types.

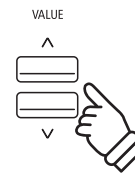
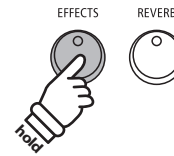

### ■ Effect settings

Effect type	Setting 1	Setting 2	Setting 3	Setting 4
Mono Delay / Ping Delay / Triple Delay	Dry / Wet	Time	Feedback	High Damp
Chorus	Dry / Wet	Speed	Feedback	Depth
Classic Chorus	Mono / Stereo	Speed	–	–
Ensemble	Dry / Wet	Speed	–	–
Tremolo	Dry / Wet	Speed	–	–
Classic Tremolo	Dry / Wet	Speed	–	–
Vibrato Tremolo	Dry / Wet	Speed	–	–
Auto Pan	Dry / Wet	Speed	–	–
Classic Auto Pan	Dry / Wet	Speed	–	–
Phaser	Dry / Wet	Speed	Feedback	Depth
Classic Phaser	Dry / Wet	Speed	Feedback	Depth
Compressor	Gain	Ratio	Threshold	Attack
Rotary 1	Accel. Speed	Rotary Speed	Lower Slow Speed	Upper Slow Speed
Rotary 2	Accel. Speed	Rotary Speed	Vibrato/Chorus	Spread

## 3. Selecting and adjusting the Effect settings

While the effects settings menu is shown in the display:

Press the  $\nabla$  or  $\wedge$  MENU buttons to cycle through the different effects settings pages.

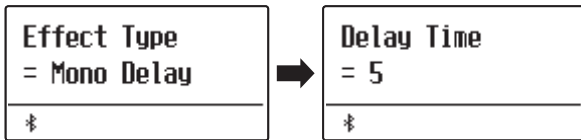

Press the  $\nabla$  or  $\wedge$  VALUE buttons to adjust the value of the selected effects setting.

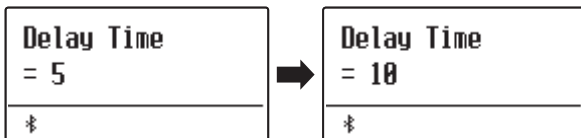

\* Effect settings can be adjusted within the range from 1 to 10 except Compressor and Rotary 2(Vibrato/Chorus).

\* Compressor settings are as follows.

- Gain (1 - 128)
- Ratio (1:1 - 64.5:1)
- Threshold (1 - 128)
- Attack (1 - 128)

\* Rotary 2(Vibrato/Chorus) settings are as follows.

- Vibrato (V-1 ~ V-3)
- Chorus (C-1 ~ C-3)

To exit the effects settings menu and return to normal playing mode, press the EXIT button or wait 4 seconds.

\* Effects settings are independent for each sound variation.

\* Any changes made to the effect type, settings, or on/off status will remain until the power is turned off.

\* Preferred effects settings can be stored to a Registration memory for convenient recall. Please refer to page 36 for more information.



*Example:* To select the "Delay Time" effects setting, press the MENU  $\wedge$  button twice.



*Example:* To increase the "Delay Time" effects setting, press and hold the VALUE  $\wedge$  button.



# 3 Amp Simulator

The ES920's Amp Simulator (Amp Sim) attempts to reproduce the sound, response, and overdrive characteristics of a typical amp/speaker combination, giving electric piano and drawbar organ sounds an authentic vintage quality. Once enabled, the amplifier type can be selected, with adjustable drive, level, and Low/Hi EQ settings. As with the Reverb and Effects functions, selecting certain sounds will enable the Amp Sim automatically.

## 1. Turning the Amp Sim on/off

Press the AMP button to turn the Amp Sim on/off.

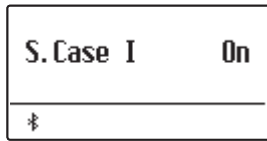

\* If Dual or Split/Four Hands modes are selected, the Amp Sim will not affect the layered or lower section sounds.

## ■ Amp Sim settings

Amp Sim setting	Description	Range
Type	Selects the amplifier/speaker type.	See below
Drive	Adjusts the drive (overdrive) level of the selected amplifier.	1~10
Level	Adjusts the volume level of the selected amplifier.	1~10
EQ Low	Adjusts the low frequency EQ level of the selected amplifier.	-6 dB~+6 dB
EQ High	Adjusts the high frequency EQ level of the selected amplifier.	-6 dB~+6 dB

## 2. Changing the Amp Sim type

While the Amp Sim settings menu is shown in the display:

Press and hold the AMP button. The Amp Sim settings menu will be shown in the display.

Press the  $\checkmark$  or  $\wedge$  VALUE buttons to cycle through the different Amp Sim types.

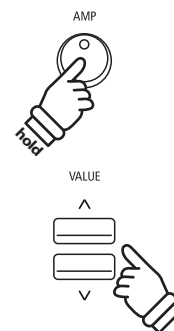
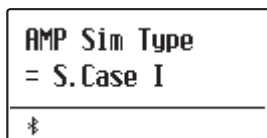

## ■ Amp Sim types

Amp Sim type	Description
S. Case I	A distantly miked suitcase type speaker, suitable for vintage electric piano sounds.
S. Case II	A closely miked suitcase type speaker, suitable for vintage electric piano sounds.
L. Cabinet	A speaker enclosed within a wooden cabinet, suitable for vintage drawbar organ sounds.

# Enhancing the Sound

## 3. Adjusting the Amp Sim settings (drive/level/eq low/eq high)

While the Amp Sim settings menu is shown in the display:

Press the  $\nabla$  or  $\wedge$  MENU buttons to cycle through the different Amp Sim settings pages, then press the  $\nabla$  or  $\wedge$  VALUE buttons to adjust the value of the selected Amp Sim setting.

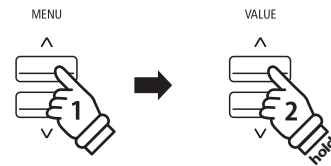
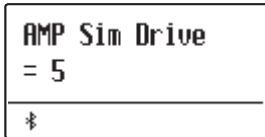

**Example:** To increase the drive of the Amp Sim, press the MENU  $\wedge$  button to select the "Amp Sim Drive" page, then press and hold the VALUE  $\wedge$  button.

To exit the Amp Sim settings menu and return to normal playing mode, press the EXIT button or wait 4 seconds.

- \* Amp Sim settings are independent for each sound variation.
- \* Any changes made to the Amp Sim type, settings, or on/off status will remain until the power is turned off.
- \* Preferred Amp Sim settings can be stored to a Registration memory for convenient recall. Please refer to page 36 for more information.

## 4 Equaliser

The Equaliser allows the volume of Low, Mid-low, Mid-high, and High frequency bands to be adjusted in real-time.

From the leftmost slider, volume of "Low", "Mid-low", "Mid-high", and "High" frequencies can be adjusted.

The 4-band equalizer can be set by Tone Control. (page 74)

Tone Control offers 8 preset types and user EQ. Settings made in Tone Control have effects on 4 sliders on the panel.

The volume range is from -6dB to +6dB; therefore, the volume may not change even when the slider is moved in some cases depending on the Tone Control settings.

For example, if the volume is set to +6dB in Tone Control, the volume does not increase when the slider is moved above the middle. Meanwhile, the volume decreases if the slider is moved below the middle.

The volume set in Tone Control applies when the slider is at the middle.

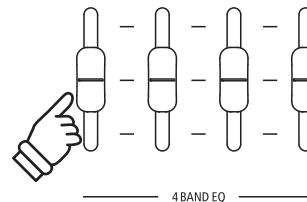

# Panel Lock

The Panel Lock function allows the state of all panel buttons to be temporarily locked, preventing sounds and other settings from being changed. This function may prove useful in teaching environments, ensuring that students are not distracted by changing sounds etc.

## 1. Activating the Panel Lock

Press the METRONOME and USB buttons simultaneously.

The Panel Lock screen will be shown in the display, and the instrument will stop responding to panel button presses.

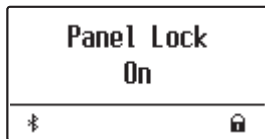
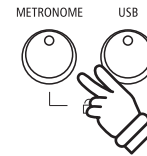

If panel buttons are pressed while the Panel Lock is activated, a reminder message will briefly be shown in the display.

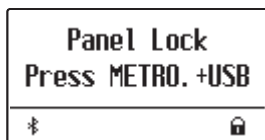

\* When activated, the Panel Lock will remain even after the power is turned off/on.

## 2. Deactivating the Panel Lock

Press the METRONOME and USB buttons simultaneously again.

A message will be shown in the display to indicate that the Panel Lock has been deactivated, and the instrument will resume responding to panel button presses as normal.

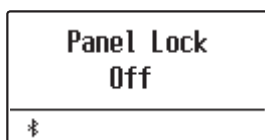
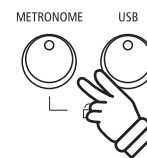

# Transpose

The Transpose function allows the pitch of the ES920 digital piano's keyboard to be raised or lowered in semi-tone intervals. This is particularly useful when accompanying instruments tuned for different keys, or when a song learned in one key must be played in another key.

- \* Changes are applied to all built-in sounds.
- \* Any changes made by this operation will remain until the power is turned off. Preferred settings can be stored in a Registration memory or Startup Setting. Please refer to page 36 and 82 for more information.

## ■ Adjusting the Key Transpose value: Method 1

Press and hold the TRANSPOSE button, then press the  $\nabla$  or  $\wedge$  VALUE buttons to adjust the key transpose value.

The LED indicator for the TRANSPOSE button will turn on to indicate that the transpose function is in use, and the key transpose value will briefly be shown in the display.

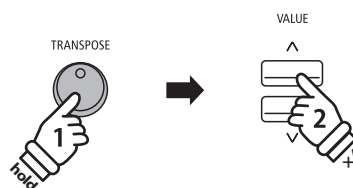
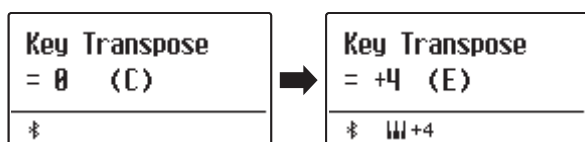

*Example:* To increase the key transpose value from 0 (off) to +4 (i.e. raise the keyboard pitch by 4 semi-tones), press and hold the TRANSPOSE button, then press the VALUE  $\wedge$  button four times.

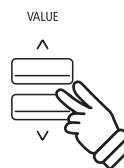

- \* The keyboard pitch can be raised or lowered by up to 12 semi-tones.
- \* To reset the key transpose value to 0, press and hold the TRANSPOSE button, then press the  $\nabla$  and  $\wedge$  VALUE buttons simultaneously.

## ■ Adjusting the Key Transpose value: Method 2

Press and hold the TRANSPOSE button, then press a key within the range of C3 to C5 to specify the value between -12 and +12.

The LED indicator for the TRANSPOSE button will turn on to indicate that the transpose function is in use, and the key transpose value will briefly be shown in the display.

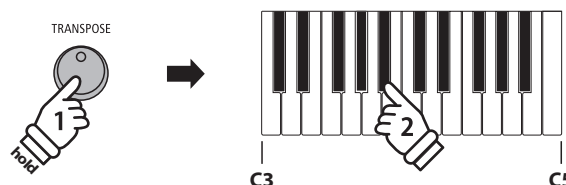
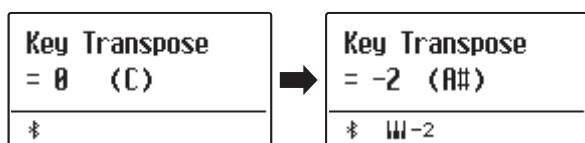

*Example:* To change the key transpose from C (off) to A (i.e. lower the keyboard pitch by three semi-tones), press and hold the TRANSPOSE button, then press the A# key.

## ■ Turning Key Transpose on/off

Press the TRANSPOSE button to turn the key transpose function on/off.



- \* The specified key transpose setting will be retained even after the key transpose function is turned off. This allows the key transpose function to be turned on and off freely, without the need to adjust the value each time.
- \* The specified key transpose setting will return to the default value of 0 after the power is turned off.
- \* Preferred key transpose settings can be stored to a Registration memory for convenient recall. Please refer to page 36 for more information.

Using the Song Transpose function it is also possible to transpose recorder songs stored in internal memory, and SMF song files stored on a USB memory device. This allows the pitch of the song to be adjusted without affecting the pitch of the keyboard.

## ■ Selecting the Song Transpose/Key Transpose settings

Press and hold the TRANSPOSE button, then press the  $\nabla$  or  $\wedge$  MENU buttons to alternate between the key transpose and song transpose settings.

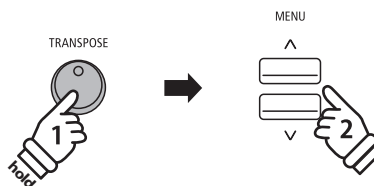

## ■ Adjusting the Song Transpose value

While the Song Transpose screen is shown in the display:

Press the  $\nabla$  or  $\wedge$  VALUE buttons to adjust the song transpose value.

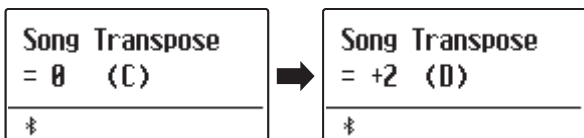

*Example: To increase the song transpose value from 0 (off) to +2 (i.e. raise the song pitch by 2 semi-tones), press and hold the TRANSPOSE button, then press the VALUE  $\wedge$  button twice.*

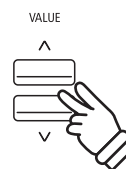

- \* The song pitch can be raised or lowered by up to 12 semi-tones.
- \* To reset the song transpose value to 0, press the  $\nabla$  and  $\wedge$  VALUE buttons simultaneously.
- \* The song transpose value will automatically reset to 0 when a different song is selected.

# Metronome

The Metronome function provides a steady beat to aid practicing the piano at a consistent tempo. The time signature, volume, and tempo of the metronome can all be freely adjusted.

## 1. Turning the Metronome on/off

Press the METRONOME button.

The LED indicator for the METRONOME button will turn on to indicate that the metronome function is in use, and a 4/4 beat will start to count.



The current metronome tempo in beats per minute (BPM) and beat of the bar will also be shown in the display.

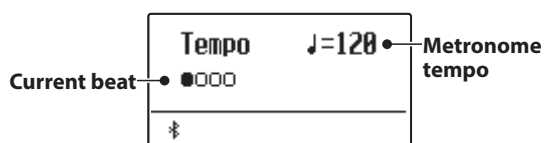

Press the EXIT or METRONOME button again to stop the metronome.

The LED indicator for the METRONOME button will turn off, the beat will stop counting, and the display will return to the normal playing mode screen.



## 2. Adjusting the Metronome settings (tempo/beat)

While the Metronome tempo screen is shown in the display, to adjust the metronome tempo:

Press the  $\nabla$  or  $\blacktriangle$  VALUE buttons to adjust the value of the metronome tempo.

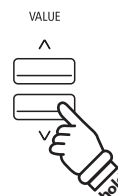
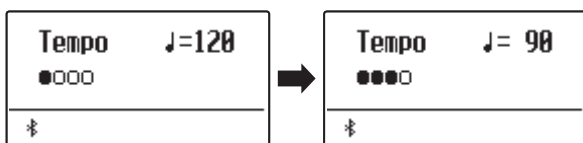

**Example:** To decrease the tempo of the metronome, press and hold the VALUE  $\nabla$  button.

\* The metronome tempo can be adjusted within the range of 10~400 beats per minute (BPM).

\* To reset the metronome tempo to 120, press the  $\nabla$  and  $\blacktriangle$  VALUE buttons simultaneously.

To adjust the metronome beat (time signature):

Press the  $\nabla$  or  $\blacktriangle$  MENU buttons to select the "Beat" page, then press the  $\nabla$  or  $\blacktriangle$  VALUE buttons to cycle through the different metronome beat (time signature) types.

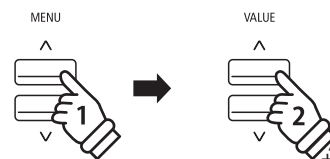

\* There are ten different types of beat (time signature) available: 1/4, 2/4, 3/4, 4/4, 5/4, 3/8, 6/8, 7/8, 9/8, and 12/8.

\* To reset the metronome beat to 4/4, press the  $\nabla$  and  $\blacktriangle$  VALUE buttons simultaneously.

**Example:** To change the beat (time signature) from 1/4 to 3/4, press the MENU  $\blacktriangle$  button to select the "Beat" page, then press the VALUE  $\blacktriangle$  button twice.

## 2. Adjusting the Metronome settings (volume)

To adjust the metronome volume:

Press the  $\nabla$  or  $\wedge$  MENU buttons to select the "Volume" page, then press the  $\nabla$  or  $\wedge$  VALUE buttons to adjust the value of the metronome volume.

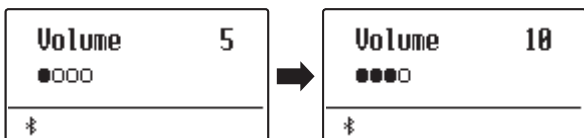

- \* The metronome volume can be adjusted within the range of 0~10.
- \* To reset the metronome volume to 5, press the  $\nabla$  and  $\wedge$  VALUE buttons simultaneously.

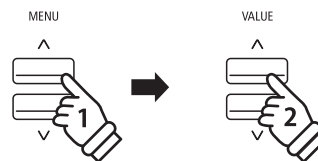

**Example:** To increase the volume of the tempo, press the MENU  $\wedge$  button to select the "Volume" page, then press the VALUE  $\wedge$  button.

### ■ Jump to Recorder shortcut

While the Metronome function is in use:

Press the ● (REC) button.

The Recorder standby screen will be shown in the display, and the metronome will count. A one bar count-in will also be played before the recording begins.

- \* Please refer to page 42 for more information about the instrument's Recorder functions.

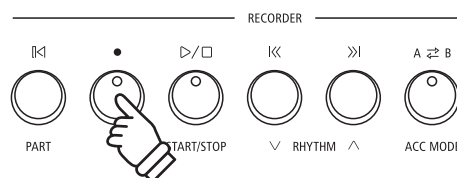

# Registration Memories

The Registration function allows the current instrument setup (sound/style selection, all settings, etc.) to be stored to a registration memory, and conveniently recalled at the touch of a button. Each of the seven registration buttons contain four banks (A, B, C, and D), allowing up to 28 different registration memories to be stored.

Registrations can also be loaded from/saved to USB memory devices. Please refer to page 61 for more information.

## Settings stored in Registration memories

General	Settings
Selected sound	Basic Settings*
Dual Mode / Split Mode (sounds, volume balance, split point)	Virtual Technician
Reverb, Effects, Amp Simulator (type, settings)	Rhythm Settings
Transpose (Key Transpose only)	Key Settings
Metronome (Beat, Tempo, Volume)	MIDI Settings

\* Wall EQ, Speaker Volume, Low Volume Balance, Line Out Volume, Audio Recorder Gain, Auto Display Off, and Auto Power Off will not be stored to Registration memories.

## Selecting a Registration memory

Press the REGISTRATION button.

The LED indicator for the REGISTRATION button will turn on to indicate that the registration function is in use, and the registration selection screen will be shown in the display.

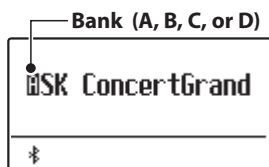

Press the SOUND buttons to select the desired registration memory. Press the same SOUND button repeatedly to cycle through the four banks (A, B, C, and D).

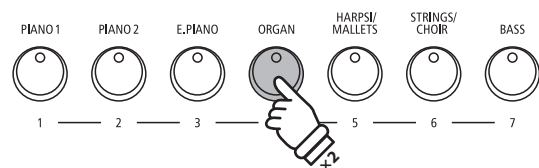

**Example:** To select registration memory 4B, press the ORGAN button (memory #4) twice.

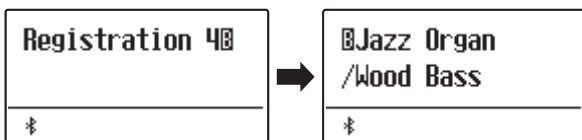

Alternatively, press the  $\nabla$  or  $\wedge$  VALUE buttons to cycle through all 28 different registration memories.

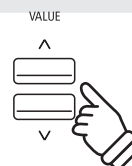

## Exiting Registration mode (restore previous settings)

To return to normal playing mode without selecting the registration (i.e. restore the previous panel settings):

Press the REGISTRATION button.

The LED indicator for the REGISTRATION button will turn off, and the instrument will return to normal playing mode.



## ■ Exiting Registration mode (retain new settings)

To return to normal playing mode with the current registration memory settings selected:

Press the EXIT button.

The LED indicator for the REGISTRATION button will turn off, and the instrument will return to normal playing mode.



## ■ Storing a Registration memory

To store a registration memory to the current banks (e.g. bank A):

Press and hold the REGISTRATION button, then press and hold a SOUND button.

The current instrument setup will be stored to the registration memory assigned to the pressed SOUND button, and a confirmation message will briefly be shown in the display.

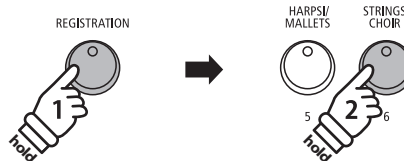

**Example:** To store the current instrument setup to memory 6A, press and hold the REGISTRATION button, then press and hold the STRINGS/CHOIR button.

To store a registration memory to a different banks (e.g. bank D):

Press and hold the REGISTRATION button, press the same SOUND button repeatedly to cycle through the four banks (A, B, C, and D), then press and hold the SOUND button.

\* The  $\vee$  or  $\wedge$  VALUE buttons can also be used to change the bank.

The current instrument setup will be stored to the registration memory and bank specified, and a confirmation message will be briefly shown in the display.

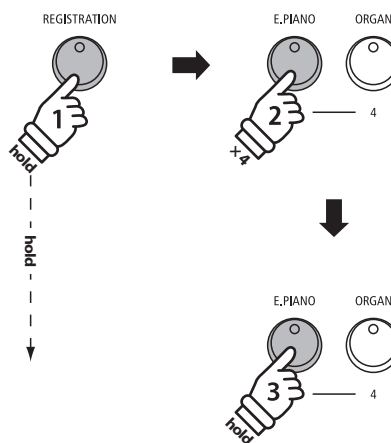
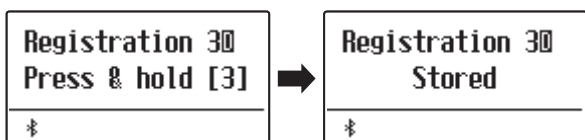

**Example:** To store the current instrument setup to memory 3D, press and hold the REGISTRATION button, press the E.PIANO button four times, then press and hold the same E.PIANO button.

## ■ Resetting all Registration memories

Press and hold the SPLIT and REGISTRATION buttons, then turn the instrument's power off/on.

All registration memories will be reset to the factory default settings.

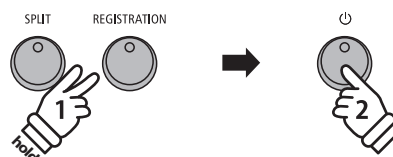

# Rhythm Section Basic Operation

The ES920's Rhythm Section feature contains 100 built-in accompaniment styles, covering a wide range of musical genres. Each style can be used simply as a drum or percussion track, or as a full musical accompaniment with bass, guitar, organ, brass, etc. parts. In addition, each style includes separate introduction, fill-in, variation, and ending passages, allowing musicians to enliven their performances at the touch of a button.

For a complete listing of the available Rhythm Section styles, please refer to page 134 of this owner's manual.

## Rhythm Section pattern types

Pattern type	Description	No. of bars
Count-in (drums only)	A short introduction pattern used to count-in the Basic/Variation pattern.	1 or 2
Basic	A simple, unobtrusive backing accompaniment pattern.	4 or 8
Variation	A more complicated version of the basic pattern, with additional phrases etc.	4 or 8
Fill-in	A short pattern that can be used when repeating phrases or as a bridge between the Basic and Variation patterns.	1
Ending	A short pattern used to bring the currently playing accompaniment style to an end.	1

## 1. Entering the Rhythm Section

Press the RHYTHM SECTION button.

The LED indicator for the RHYTHM SECTION button will turn on to indicate that the Rhythm Section is in use.



Information about the currently selected style will also be shown in the display.

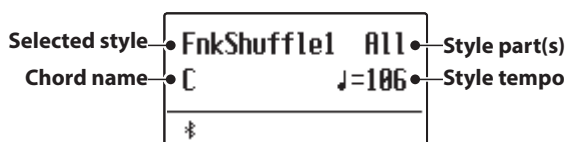

The entire keyboard can be used to play the melody, with the ES920 detecting and changing the Rhythm Section chord/key automatically.

### Full keyboard:

Used to control the accompaniment, and play the melody.

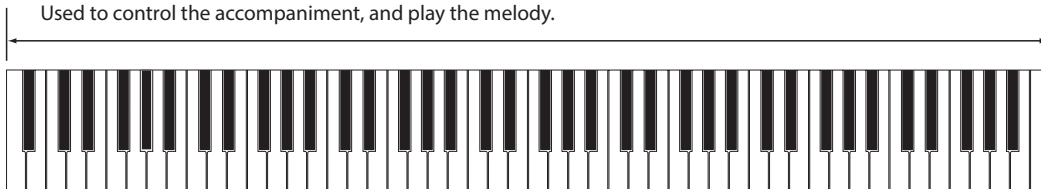

## 2. Playing with the Rhythm Section

Press the PLAY/STOP button.

The LED indicator for the PLAY/STOP button will turn on, and the count-in drum pattern will start to play.

After the Count-in, the Rhythm Section will change to the Basic pattern. During this time, playing full fingered chords will also change the accompaniment's chords, while single notes play the melody.

After 8 bars of the Basic pattern have been played, the Rhythm Section will automatically play the Fill-in pattern.

\* Please refer to page 114 for more information about the Rhythm Section's Auto Fill-in function.

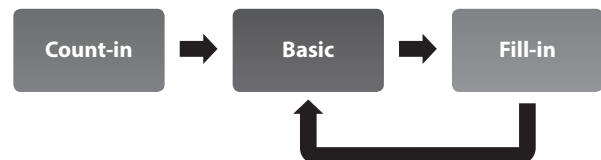
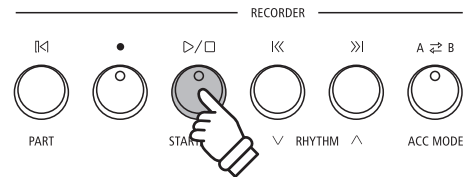

## 3. Adding the full backing accompaniment

The full backing accompaniment will begin to play in the key specified, and the name of the chord will be shown in the display.

\* The Rhythm Section recognises 15 different chords types, including most inversions. Please refer to page 135 for more information.

\* When the Bass Inv. setting is set to "On", the On-Bass chord can be recognised when playing bass notes with the left hand. Please refer to page 118.

\* When the ACC Mode setting is set to "1 Finger Chord", the Rhythm Section accompaniment can be changed by playing single notes's. Please refer to page 116.

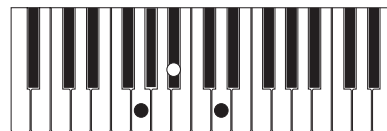

*Example: To play the backing accompaniment in the key of G minor, press the G, B<sup>b</sup> and D keys in the lower section simultaneously.*

## 4. Stopping and exiting the Rhythm Section

Press the PLAY/STOP button again.

The Rhythm Section will play the ending pattern, the backing accompaniment will stop, and the LED indicator for the PLAY/STOP button will turn off.

Press the RHYTHM SECTION button again to return to normal playing mode.



# Rhythm Section Basic Operation

## Rhythm Section Style

The ES920 digital piano features 100 different accompaniment styles, ranging from Pop, Rock, Ballads, and Jazz, to Funk, Dance, Latin, and World Music styles.

For a complete listing of the available Rhythm Section styles, please refer to page 134 of this owner's manual.

### ■ Selecting the Rhythm Section style

While the main Rhythm Section screen is shown in the display:

Press the  $\nabla$  or  $\blacktriangle$  RHYTHM (REW or FWD) buttons to cycle through the different Rhythm Section styles.

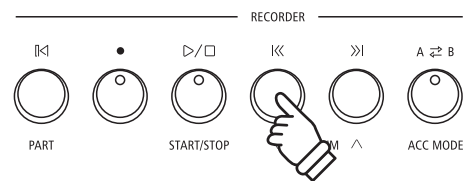
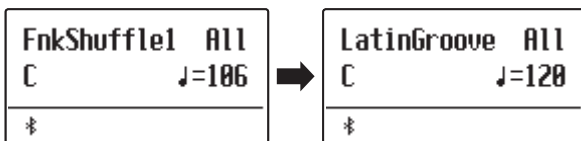

Each style features both a “basic” and “variation” pattern. If the “variation” pattern is selected, a  $\square$  symbol will be shown in the display.

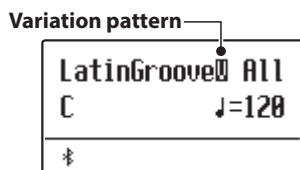

- \* The selected Rhythm Section style setting will remain until the power is turned off.
- \* The preferred Rhythm Section style can be stored to a Registration memory for convenient recall. Please refer to page 36 for more information.

### ■ Jump to Rhythm Section genre

It is also possible to cycle through the different Rhythm Section genres, instead of individual styles.

Press and hold the RHYTHM SECTION button, then press the  $\nabla$  or  $\blacktriangle$  RHYTHM (REW or FWD) buttons to cycle through the different Rhythm Section genres.

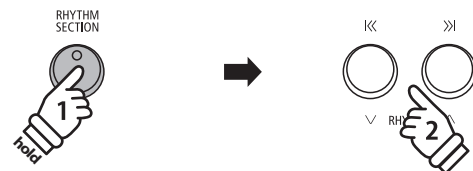
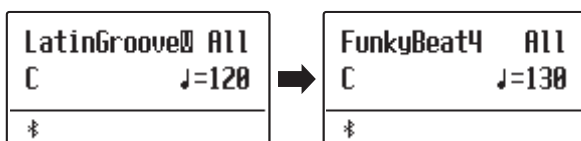

# Rhythm Section Parts

Each Rhythm Section style consists of several different instrument parts. It is possible to specify whether the Rhythm Section should play drums only, bass and drums, or a full backing accompaniment.

## Rhythm Section parts

R.S. Parts	display	Description
Drums	Drum	The Rhythm Section will play a drum track only.
Bass & Drums	B+Dr	The Rhythm Section will play both bass and drum tracks.
All Parts (default)	All	The Rhythm Section will play a full backing accompaniment (drums, bass, guitar, etc.)

## Changing the Rhythm Section parts

While the main Rhythm Section screen is shown in the display:

Press the PART (RESET) button to cycle through the different Rhythm Section part settings.

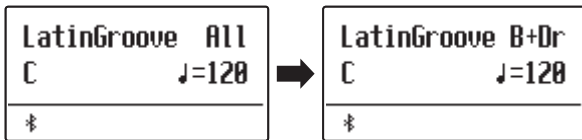
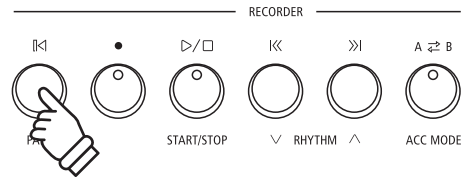

## Adjusting the Rhythm Section tempo

While the main Rhythm Section screen is shown in the display:

Press the ∨ or ∧ VALUE buttons to decrease or increase the tempo of the Rhythm Section.

\* The Rhythm Section and Metronome share the same tempo setting.

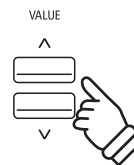

# Song Recorder (Internal memory)

The ES920 digital piano allows up to 10 different songs to be recorded, stored in internal memory, and played back at the touch of a button. Each song consists of two separate tracks - referred to as "parts" - that can be recorded and played back independently. This allows the left-hand part of a song to be recorded first on one track, and the right-hand part to be recorded later on the other track.

## 1 Recording a Song

### 1. Entering song recorder mode

Press the ● (REC) button.

The LED indicator for the ● (REC) button will start to flash, and the Internal Song Recorder screen will be shown in the display.

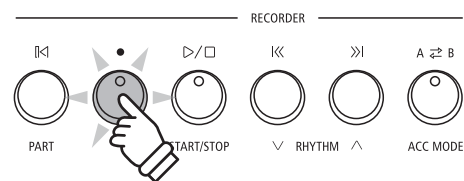
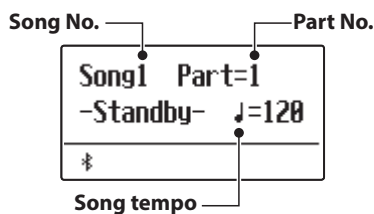

\* If a USB memory device is connected, press the MENU / button to select the "Int. Recorder" function.

\* The Recorder shares the song tempo setting with the Metronome and Rhythm Section functions.

### 2. Selecting the song/part to be recorded

Press the REW or FWD buttons to select the internal song memory (1~10) to be recorded to.

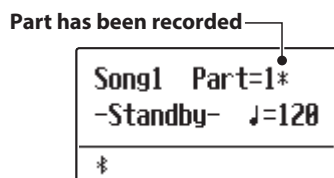

Then press the √ or ^ VALUE buttons to select the part number (1 or 2) to be recorded.

\* If a part has already been recorded, a ⌘ symbol will be shown.

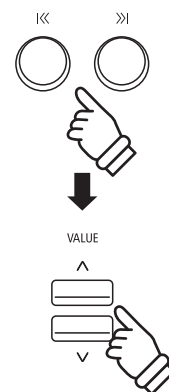

**When recording part 1 and part 2 separately, select the song and part number carefully in order to prevent accidentally overwriting a previously recorded part.**

### 3. Starting the song recorder

Recording starts when the instrument is played.

The LED indicators for the ● (REC) and PLAY/STOP buttons will turn on, and recording will start.

The current bar and beat will also be shown in the display.

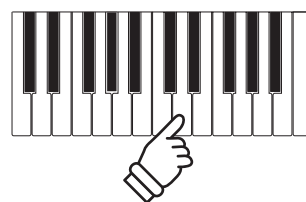
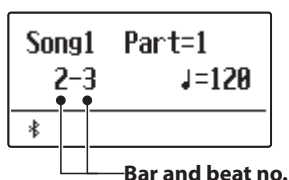

or



\* Recording can also be started by pressing the PLAY/STOP button, allowing a rest period or empty bar to be inserted at the beginning of the song.

## 4. Stopping the song recorder

Press the PLAY/STOP button.

The LED indicators for the PLAY/STOP and ● (REC) buttons will turn off, the recorder will stop, and the part/song will be stored in internal memory.

After a few seconds, the Internal Song Player screen will be shown in the display, indicating that the song is ready for playback.

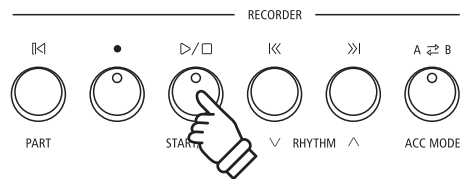
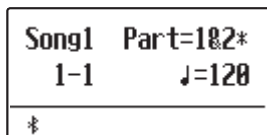

- \* The maximum recording capacity is approximately 90,000 notes, with button and pedal presses also counted as one note.
- \* If the maximum recording capacity is reached during recording, the recorder will stop automatically.
- \* Recorder songs will remain in memory after the power is turned off.

### ■ Recording a second part

To record a second part, repeat the above instructions, selecting the part that has not been recorded to.

### ■ Recording with the metronome

It is also possible to record songs with the metronome activated. This is useful when recording parts separately, or wishing to maintain correct timing throughout complex passages. Note that the metronome will not be heard when the song is played back.

\* Please refer to page 34 for more information about using the instrument's Metronome function with the Recorder.

### ■ Changing panel settings while recording

In some cases, it may be desirable to make changes to the selected sound or style while recording a song. The tables below list the various functions which will and will not be remembered during recording.

#### Panel operations remembered during recording

- Changes made to the sound type. (SOUND buttons etc.)
- Switching between dual/split modes.

#### Panel operations NOT remembered during recording\*

- Changes made to the reverb settings.
- Changes made to the effects settings.
- Changes made to the tempo.
- Changes made to the volume balance in dual/split mode.
- Changes made to transpose, tuning, touch, etc.

\* Make changes to desired effects, reverb, and tempo settings etc. before recording a new song.

## 5. Exiting song recorder mode

Press the EXIT button to exit the Internal Song Recorder.

The instrument will return to normal playing mode.

EXIT



## 2 Playing a Song

This function is used to playback songs stored in the internal recorder. To playback a song/part immediately after recording, start this process from step 2.

### 1. Entering song play mode

Press the PLAY/STOP button.

The LED indicator for the PLAY/STOP button will turn on, and the Internal Song Player screen will be shown in the display.

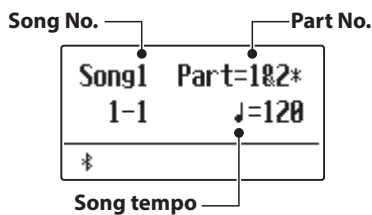
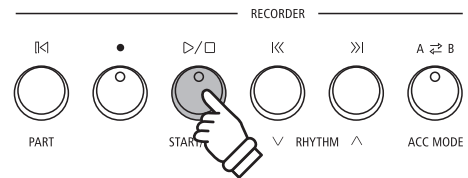

\* If a USB memory device is connected, press the MENU ^ button to select the "Int. Recorder" function.

### 2. Selecting the song/part to be played back

Press the REW or FWD buttons to select the internal song memory (1~10) to be played back.

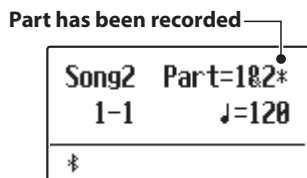
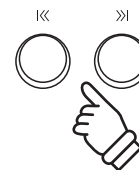

\* If a part has already been recorded, a \* symbol will be shown.

To select the part(s) of the song to be played back:

Press the ∇ or ▲ MENU buttons to select the Song Part setting, then press the ∇ or ▲ VALUE buttons to select the desired part(s).

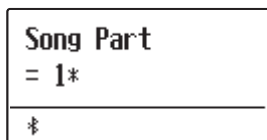
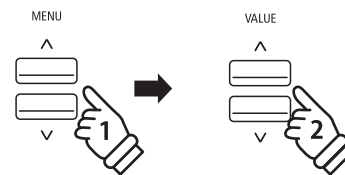

### 3. Starting song playback

Press the PLAY/STOP button.

The selected song/part(s) will start to play, and the current bar and beat will also be shown in the display.

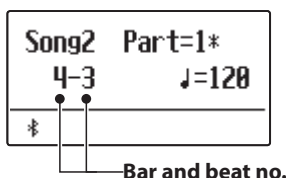
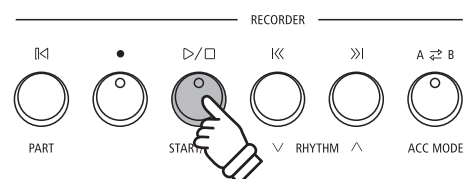

## ■ Controlling song playback

While the song is playing:

Press the REW or FWD buttons to rewind or advance the playing position of the song. When the playing position is reset, these buttons allow the song memory to be selected.

Press the A-B LOOP button twice to set the start and end points of the loop.

\* Pressing the A-B LOOP button for a third time will turn off the loop.

Press the PLAY/STOP button to pause and resume song playback.

Press the RESET button to return to the beginning of the song.

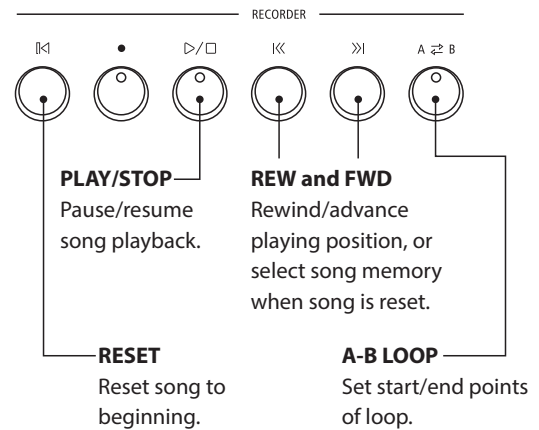

## ■ Adjusting the playback tempo

While the song is playing:

Press the ∨ or ∧ VALUE buttons to adjust the playback tempo.

\* The playback tempo can be adjusted within the range of 10~400 beats per minute (BPM).

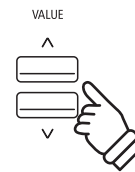

## ■ Adjusting playback settings (playback menu)

The playback menu features settings to adjust the song volume, and pitch (transpose), and change the selected playing part(s).

While the song is playing:

Press the ∨ or ∧ MENU buttons to enter the playback menu and select the desired setting, then press the ∨ or ∧ VALUE buttons to adjust the setting value.

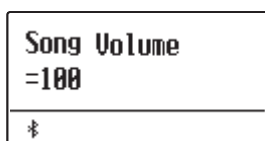
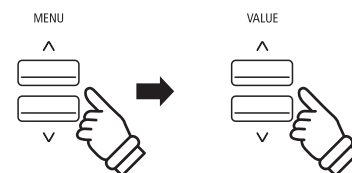

\* The song volume setting can be adjusted within the range of 1~100.

\* The song pitch can be raised or lowered by up to 12 semi-tones.

\* The song part setting cycles through part 1, part 2, and parts 1&2.

Press the EXIT button to return to the Internal Song Play screen.



## 4. Exiting song play mode

Press the EXIT button to exit the Internal Song Player.

The instrument will return to normal playing mode.

\* Press the EXIT button twice if a USB memory device is connected.



## 3 Recording a Song with the Rhythm Section

It is also possible to record songs while using the Rhythm Section. This feature can be used to record backing accompaniments (including chord changes) for favourite songs, allowing the player to concentrate on the melody or improvised solos using the full keyboard.

The Rhythm Section can only be recorded to Part 1 of each song memory.

### 1. Entering the Rhythm Section

Press the RHYTHM SECTION button.

The LED indicator for the RHYTHM SECTION button will turn on to indicate that the Rhythm Section is in use.

Make any changes to the Rhythm Section settings (style, volume, tempo, parts, ACC mode etc.)

\* Please refer to page 113 for more information.



### 2. Entering song recorder mode

Press the ● (REC) button.

The LED indicator for the ● (REC) button will start to flash, and the Internal Song Recorder screen will be shown in the display.

\* If a USB memory device is connected, press the MENU ^ button to select the "Int. Recorder" function.

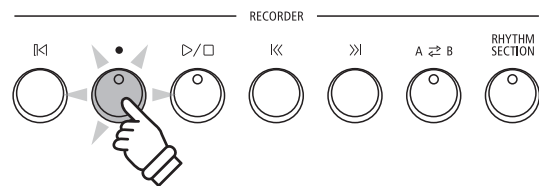

### 3. Selecting the song to be recorded

Press the REW or FWD buttons to select the internal song memory (1~10) to be recorded to.

\* Part 1 must be selected in order to record the Rhythm Section. The Rhythm Section will not be recorded if Part 2 is selected.

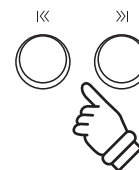

### 4. Starting the song recorder

Press a key on the keyboard, or press the PLAY/STOP button.

The LED indicators for the ● (REC) and PLAY/STOP buttons will turn on, and recording will start with the Rhythm Section playing.

Press the PLAY/STOP button to stop the recording.

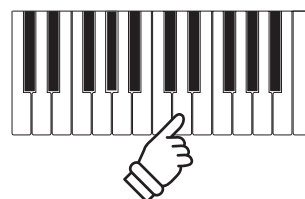

or



# 4 Erasing a Part/Song

This function is used to erase recorder parts that have been recorded incorrectly or songs that are no longer listened to. Once a part/song has been erased from memory it cannot be recovered.

## 1. Entering song erase mode

Press the ● (REC) and PLAY/STOP buttons simultaneously.

The LED indicators for the ● (REC) and PLAY/STOP buttons will start to flash, and the Erase Song screen with the currently selected song and part number will be shown in the display.

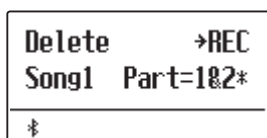
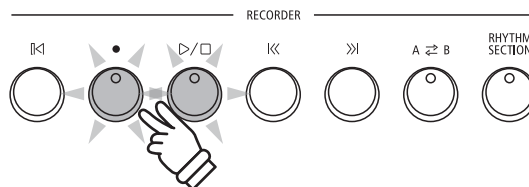

## 2. Selecting a song and part(s) to be erased

Press the REW or FWD buttons to select the internal song memory (1~10) to be erased.

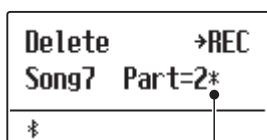

Parts have been recorded

Then press the ∨ or ^ VALUE buttons to select the part number(s) (1, 2, or 1&2) of the selected song to be erased.

\* If a part has already been recorded, a \* symbol will be shown.

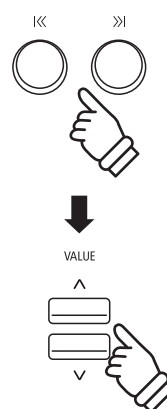

## 3. Erasing the selected song and part(s)

Press the ● (REC) button.

A confirmation message will be shown in the display, prompting to confirm or cancel the erase operation.

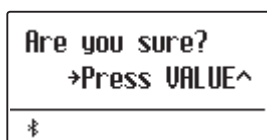

Press the VALUE ^ button to confirm the erase operation and return to the Internal Song Player screen.

Press the EXIT button to cancel the erase operation.

\* If cancelled, press the PLAY/STOP button to return to the Play Internal screen, or ● (REC) button to return to the Record Internal screen.

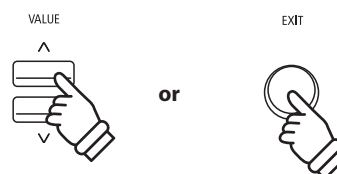
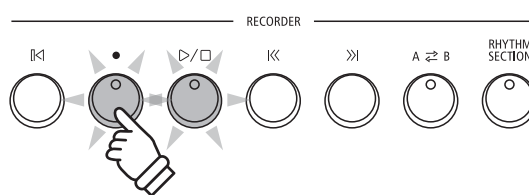

## Erasing all recorder songs from memory

Press and hold the PLAY/STOP and ● (REC) buttons, then turn the instrument's power off/on.

All recorder songs stored in memory will be erased.

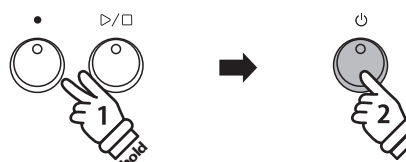

# Audio Record/Playback (USB memory)

The ES920 digital piano is also capable of recording performances as digital audio - saving the data to a USB memory device in either MP3 or WAV format. This useful function allows professional quality recordings to be produced directly on the instrument - without the need for additional sound equipment - then emailed to band members, listened to away from the instrument, or edited and remixed further using an audio workstation.

\* USB devices should be formatted to use the FAT or FAT32 file systems.

## ■ Audio Recorder format specifications

Audio Format	Specifications	Bitrate
MP3	44.1 kHz, 16 bit, Stereo	256 kbit/s (fixed)
WAV	44.1 kHz, 16 bit, Stereo	1,411 kbit/s (uncompressed)

## 1 Recording an Audio file

### 1. Entering USB recorder mode

Connect a USB memory device to the USB port.

Press the ● (REC) button, then press the MENU ∨ button to select the "USB Recorder" function.

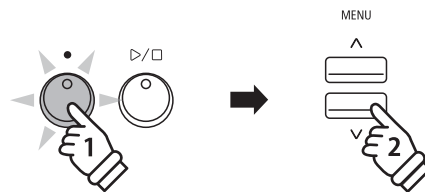

The LED indicator for the ● (REC) button will start to flash, and the USB Recorder screen will be shown in the display.

### 2. Selecting the audio recorder file format

Press the ∨ or ^ VALUE buttons to select the desired audio recorder file format (MP3 or WAV).

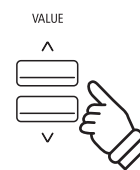

\* MP3 audio files require less storage space than WAV audio files.

\* A 1 GB USB memory device can store over 12 hours of MP3 audio data.

### 3. Starting the audio recorder

Press a key on the keyboard.

The LED indicators for the ● (REC) and PLAY/STOP buttons will turn on, and recording will start.

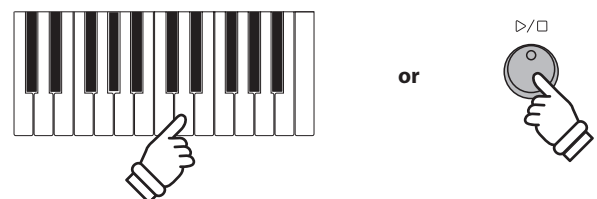

The recording status will also be shown in the display.

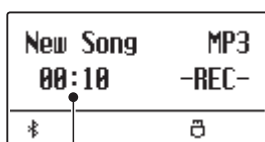

Recording time

\* Recording can also be started by pressing the PLAY/STOP button, allowing a rest period or empty bar to be inserted at the beginning of the song.

## 4. Stopping the audio recorder, saving to USB

Press the PLAY/STOP button.

The LED indicators for the PLAY/STOP and ● (REC) buttons will turn off, and recording will stop.

A confirmation message will be shown in the display, prompting to save the recorded audio file.

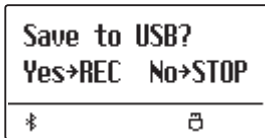

Press the ● (REC) button to continue, or the PLAY/STOP button to cancel the save operation.

\* If cancelled, the audio recorder will return to the previous screen.

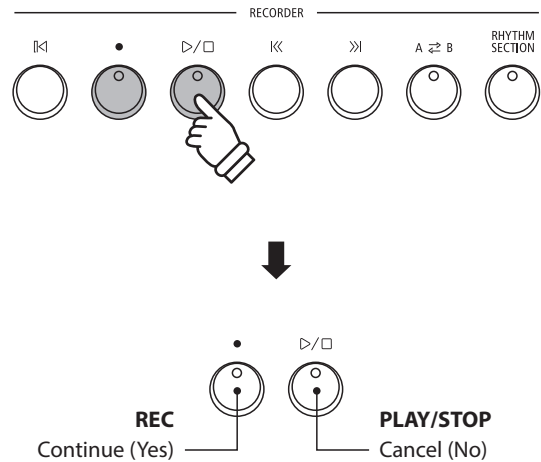

## 5. Naming the recorded audio file, confirming save

After pressing the ● (REC) button to continue the save:

The filename entry screen will be shown in the display.

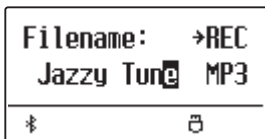

Press the ∨ or ∧ VALUE buttons to cycle through the characters, and the ∨ or ∧ MENU buttons to move the cursor.

Press the ● (REC) button again to save the recorded audio file with the specified filename.

After a few seconds, the Audio Player screen will be shown in the display, indicating that the song is ready for playback.

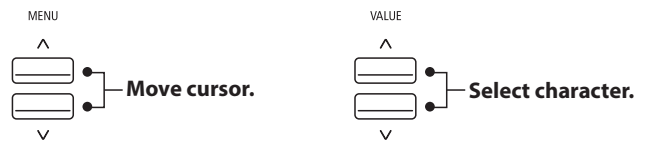
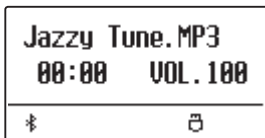

- \* "Audio-000.MP3" or "Audio-000.WAV" will be used as the default name for the recorded audio files, with the number increasing automatically.
- \* Saved files are limited to a maximum name length of 11 characters.
- \* The saved audio file will be stored in the root folder of the USB memory device. It is not possible to store the file in a different folder.
- \* The audio recorder will only record sounds produced by the instrument. Devices connected via the LINE IN jacks will not be recorded.

### Overwriting a file

If the specified filename already exists:

A confirmation message will be shown in the display, prompting to confirm or cancel the overwrite operation.

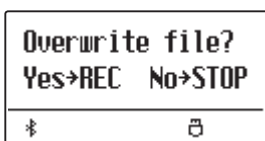

Press the ● (REC) button to confirm the overwrite, or the PLAY/STOP button to cancel.

\* If cancelled, the audio recorder will return to the saving screen (step 4).

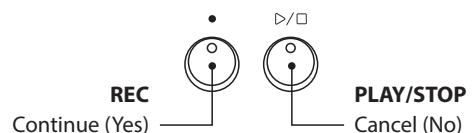

## 2 Playing an Audio file

The ES920 digital piano is also capable of playing MP3 and WAV audio files stored on a USB memory device directly through the instrument's speaker system. This function is particularly useful when attempting to learn the chords or melody to a new piece, or to simply play along with one's favourite song.

### ■ Audio Player supported format specifications

Audio Format	Specifications	Bitrate
MP3	32 kHz/44.1 kHz/48 kHz, Mono/Stereo	8~320 kbit/s (fixed & variable)
WAV	32 kHz/44.1 kHz/48 kHz, Mono/Stereo, 16 bit	-

### ■ Preparing the USB memory device

First, prepare a selection of MP3 or WAV audio files, copying the data to a USB memory device.



#### 1. Entering USB playback mode

Connect a USB memory device to the USB port.

Press the PLAY/STOP button, then press the MENU  $\nabla$  button to select the "USB Recorder" function.

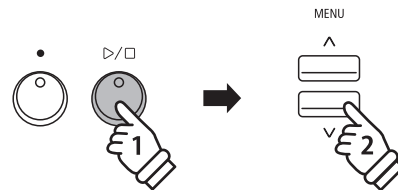

The LED indicator for the PLAY/STOP button will turn on, and the file selection screen will be shown in the display.

### ■ File selection screen

The file selection screen provides a listing of relevant files and folders stored on the connected USB device.

The  $\blacktriangleright$  symbol is used to indicate the selected file/folder. The  $\triangleleft$   $\triangleright$  symbols are used to indicate a folder.

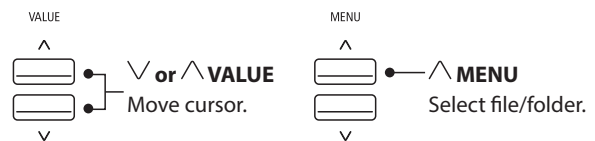

An example of a typical file/folder listing screen is shown below. The visible screen height has been extended for the purpose of this illustration.

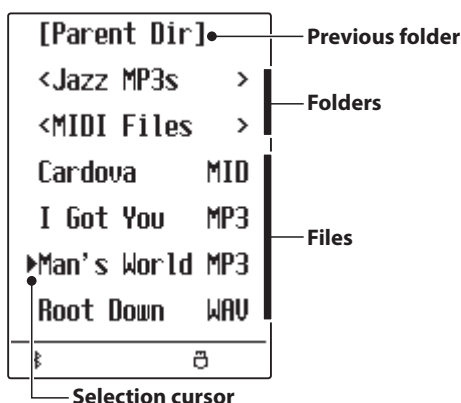

- \* Files and folders will be listed in alphabetical order, with folders shown at the top of the screen.
- \* When the USB Recorder function is selected, MP3, WAV, MID, and KSO files will be shown.
- \* The display is capable of showing filenames with a maximum length of 11 characters (+3 character suffix). Filenames longer than 11 characters will be truncated automatically.

## 2. Selecting and playing an audio file

Press the  $\nabla$  or  $\wedge$  VALUE buttons to move the selection cursor, then press the MENU  $\wedge$  button to select the file.

The audio play screen will be shown in the display.



Press the PLAY/STOP button.

The LED indicator for the PLAY/STOP button will turn on and the selected audio file will start to play.

\* To activate the "Chain Play" mode, press and hold the PLAY/STOP button when selecting the file. The contents of the current folder will be played in alphabetical order after the initial file has finished playing.

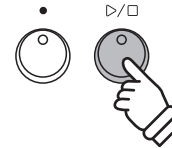
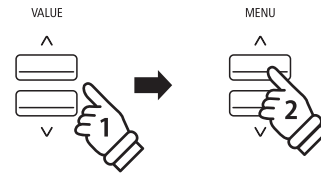

\* If the selected audio file contains embedded metadata (e.g. ID3 tags) such as artist name and song title, this information will be shown beside the filename, on the top line of the display.

## ■ Controlling audio file playback

While the audio file is playing:

Press the REW or FWD buttons to rewind or advance the playing position of the audio file. When the playing position is reset, these button allow the file/folder to be selected.

Press the A-B LOOP button twice to set the start and end points of the loop.

\* Pressing the A-B LOOP button for a third time will turn off the loop.

Press the PLAY/STOP button to pause and resume playback.

Press the RESET button to return to the beginning of the audio file.

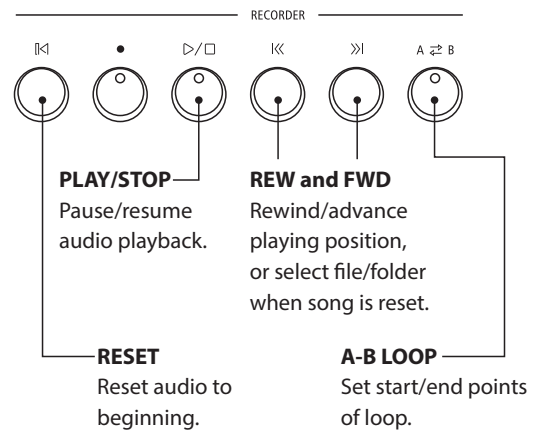

## ■ Adjusting the audio file playback volume

Press the  $\nabla$  or  $\wedge$  VALUE buttons to adjust the playback volume.

\* The playback volume can be adjusted within the range of 1~100.

\* There may be a noticeable difference in volume between audio file playback and the ES920 keyboard sound. When playing back MP3/WAV audio data, please adjust the volume of the audio file as desired.

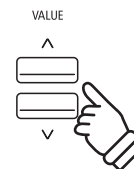

## 3. Exiting USB playback mode

Press the EXIT button to exit the USB Recorder.

The instrument will return to normal playing mode.



## 3 Overdubbing an Audio file

This function allows the sound of the ES920 to be recorded (overdubbed) to an existing MP3 or WAV audio file.

### 1. Entering USB recorder mode

Connect a USB memory device to the USB port.

Press the PLAY/STOP button, then press the MENU  $\nabla$  button to select the "USB Recorder" function.

The LED indicator for the PLAY/STOP button will turn on, and the file selection screen will be shown in the display.

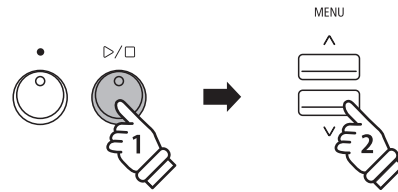

### 2. Selecting an audio file

Press the  $\nabla$  or  $\wedge$  VALUE buttons to move the selection cursor, then press the MENU  $\wedge$  button to select the file.

The audio play screen will be shown in the display.

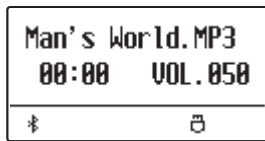
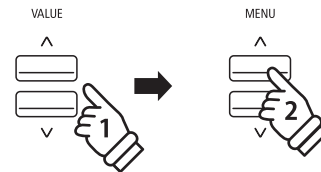

### 3. Selecting Overdubbing mode

Press the  $\bullet$  (REC) button.

Overdubbing mode will be selected automatically.

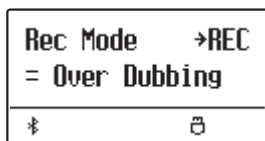
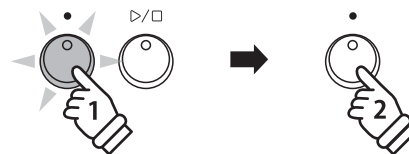

\* To record a new song, press the  $\nabla$  or  $\wedge$  VALUE buttons to select New Song mode.

Press the  $\bullet$  (REC) button again.

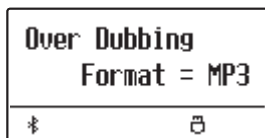

## 4. Selecting the audio recorder file format

Press the  $\vee$  or  $\wedge$  VALUE buttons to select the desired audio recorder file format (MP3 or WAV).

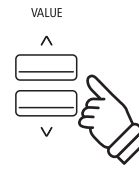

## 5. Starting the audio recorder

Press a key on the keyboard, or press the PLAY/STOP button.

The LED indicators for the ● (REC) and PLAY/STOP buttons will turn on, the selected audio file will begin to play, and overdubbing will start.

\* The name of the selected audio file will be used as the default name for the overdubbed audio file.

\* Saved files are limited to a maximum name length of 11 characters.

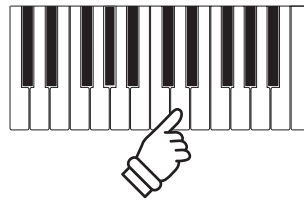

or



## 4 Playing a MIDI file

The ES920 digital piano also supports the playback of Standard MIDI File (SMF) song files stored on a USB memory device, allowing a vast selection of widely accessible music to be heard through the instrument's exquisite Harmonic Imaging XL sound engine.

### ■ Song Player supported format specifications

Song Format	Specifications
MID	Format 0, Format 1

### ■ Preparing the USB memory device

First, prepare a selection of MID (SMF) song files, copying the data to a USB memory device.



#### 1. Entering USB playback mode

Connect a USB memory device to the USB port.

Press the PLAY/STOP button, then press the MENU  $\nabla$  button to select the "USB Recorder" function.

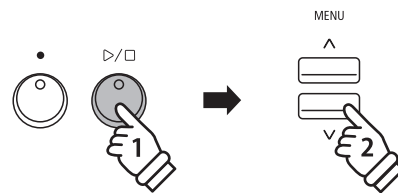

The LED indicator for the PLAY/STOP button will turn on, and the file selection screen will be shown in the display.

\* Please refer to page 50 for information about the file selection screen.

#### 2. Selecting and playing a MIDI file.

Press the  $\nabla$  or  $\wedge$  VALUE buttons to move the selection cursor, then press the MENU  $\wedge$  button to select the MIDI file.

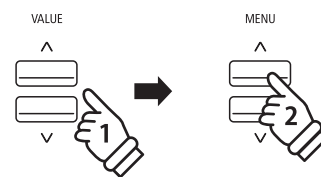

The MIDI player screen will be shown in the display.

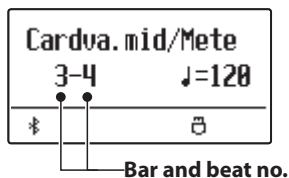

Press the PLAY/STOP button.

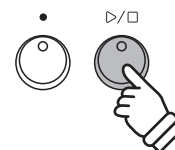

The LED indicator for the PLAY/STOP button will turn on and the selected MIDI file will start to play.

\* To activate the "Chain Play" mode, press and hold the PLAY/STOP button when selecting the file. The contents of the current folder will be played in alphabetical order after the initial file has finished playing.

\* The ES920 digital piano does not contain the full General MIDI/GM2 sound bank selection. Consequently, some SMF song files may not be reproduced entirely accurately when played through the instrument.

## ■ Controlling MIDI file playback

While the MIDI file is playing:

Press the REW or FWD buttons to rewind or advance the playing position of the MIDI file. When the playing position is reset, these button allow the file/folder to be selected.

Press the A-B LOOP button twice to set the start and end points of the loop.

\* Pressing the A-B LOOP button for a third time will turn off the loop.

Press the PLAY/STOP button to pause and resume playback.

Press the RESET button to return to the beginning of the MIDI file.

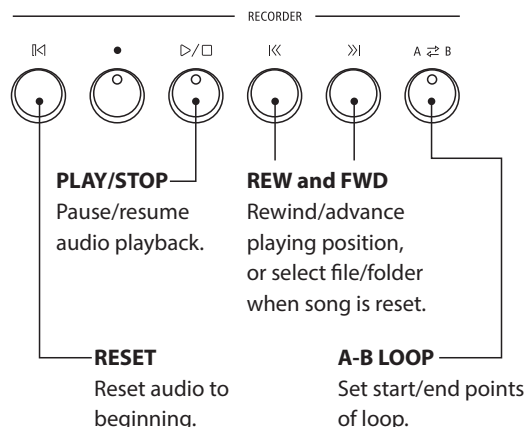

## ■ Adjusting the MIDI file playback tempo

Press the ∨ or ∧ VALUE buttons to adjust the playback tempo.

\* The playback tempo can be adjusted within the range of 10~400.

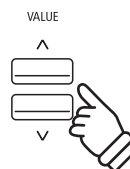

## ■ Adjusting playback settings (playback menu)

The playback menu features settings to adjust the MIDI file's volume, and pitch (transpose), and select the "Minus One" part.

While the MIDI file is playing:

Press the ∨ or ∧ MENU buttons to enter the playback menu and select the desired setting, then press the ∨ or ∧ VALUE buttons to adjust the setting value.

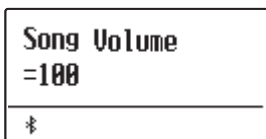

\* The song volume setting can be adjusted within the range of 1~100.

\* The song pitch can be raised or lowered by up to 12 semi-tones.

\* The minus one part setting can be set to channels 1~16 or set to Off.

Press the EXIT button to return to the song player screen.

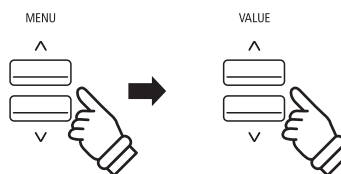

## 3. Exiting USB playback mode

Press the EXIT button to exit the USB Recorder.

The instrument will return to normal playing mode.



## 5 Converting a MIDI file to an Audio file

This function allows MIDI files or ES920 recorder songs stored on a USB memory device to be played back and saved (converted) as an audio file (to the USB device) in either MP3 or WAV format.

### 1. Entering USB recorder mode

Connect a USB memory device to the USB port.

Press the PLAY/STOP button, then press the MENU  $\nabla$  button to select the "USB Recorder" function.

The file selection screen will be shown in the display.

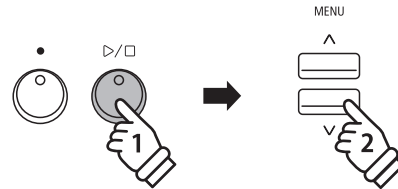

### 2. Selecting a MIDI file

Press the  $\nabla$  or  $\wedge$  VALUE buttons to move the selection cursor, then press the MENU  $\wedge$  button to select the MIDI file.

The MIDI player screen will be shown in the display.

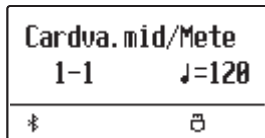
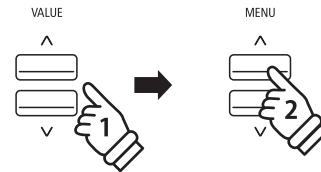

### 3. Selecting Convert To Audio mode

Press the ● (REC) button.

ConvertToAudio mode will be selected automatically.

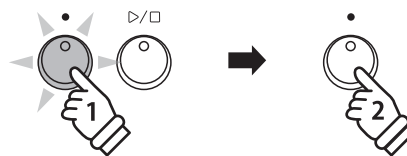

\* To record a new song, press the  $\nabla$  or  $\wedge$  VALUE buttons to select New Song mode.

Press the ● (REC) button again.

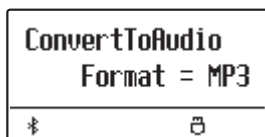

## 4. Selecting the audio recorder file format

Press the  $\vee$  or  $\wedge$  VALUE buttons to select the desired audio recorder file format (MP3 or WAV).

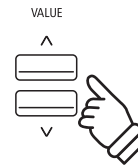
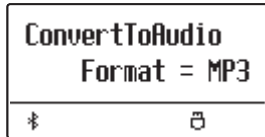

## 5. Starting the Conversion

Press the PLAY/STOP button.

The LED indicators for the ● (REC) and PLAY/STOP buttons will turn on, and conversion will start.

The conversion status will also be shown in the display.



- \* Notes played on the keyboard will also be recorded to the audio file.
- \* When the end of the song is reached, the conversion will stop and the save confirmation screen will be shown automatically.
- \* The name of the selected MIDI file will be used as the default name for the recorded audio file.
- \* Saved files are limited to a maximum name length of 11 characters.

## 6 Recording an Audio file with the Rhythm Section

The ES920 digital piano also allows MP3 or WAV audio files to be recorded while using the Rhythm Section. This feature can be used to produce high quality digital audio recordings with full accompaniment backing, which can then be shared with friends and family.

### 1. Entering the Rhythm Section

Press the RHYTHM SECTION button.

The LED indicator for the RHYTHM SECTION button will turn on to indicate that the Rhythm Section is in use.

Make any changes to the Rhythm Section settings (style, volume, tempo, parts, ACC mode etc.)

\* Please refer to page 113 for more information.



### 2. Entering USB recorder mode, selecting the audio file format

Connect a USB memory device to the USB port.

Press the ● (REC) button, then press the MENU ∨ button to select the "USB Recorder" function.

The USB Recorder screen will be shown in the display.

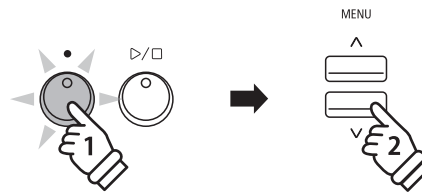

Press the ∨ or ^ VALUE buttons to select the desired audio recorder file format (MP3 or WAV).

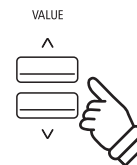

### 3. Starting the audio recorder

Press a key on the keyboard, or press the PLAY/STOP button.

The LED indicators for the ● (REC) and PLAY/STOP buttons will turn on, and recording will start with the Rhythm Section playing.

Press the PLAY/STOP button to stop the recording.

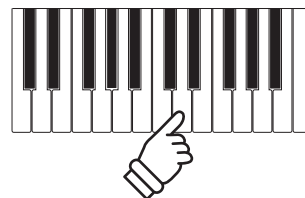

or



### 4. Naming and saving the recorded audio file

Please follow the "Recording an Audio File" instructions on page 49 from step 4.

# 7 Converting a Song to an Audio file

The ES920 digital piano allows recorder songs stored in internal memory to be played back and saved (converted) as an audio file to a USB device in either MP3 or WAV format.

## 1. Selecting a song

After recording a song to internal memory:

Connect a USB memory device to the USB port.

Press the PLAY/STOP button, then press the MENU  $\wedge$  button to select the "Int. Recorder" function.

The LED indicator for the PLAY/STOP button will turn on and the Internal Song Player screen will be shown in the display.

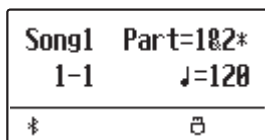

Press the REW or FWD buttons to select the desired internal song memory, and the  $\vee$  or  $\wedge$  VALUE buttons to select the desired part(s).

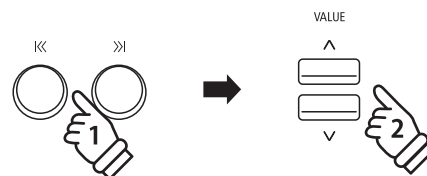
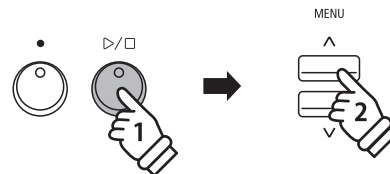

## 2. Selecting the Convert to Audio function

Press the USB button.

The Convert to Audio function will be shown in the display.

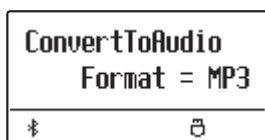

Press the  $\vee$  or  $\wedge$  VALUE buttons to select the desired audio file format for the converted song.

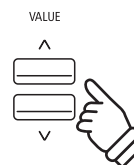

## 3. Starting the conversion

Press the PLAY/STOP button.

The LED indicators for the  $\bullet$  (REC) and PLAY/STOP buttons will turn on, and conversion will start.

The conversion status will also be shown in the display.

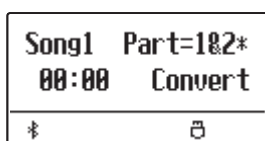

- \* Notes played on the keyboard will also be recorded to the audio file.
- \* When the end of the song is reached, the conversion will stop and the save confirmation screen will be shown automatically.

## 4. Naming and saving the converted audio file

Please follow the "Recording an Audio File" instructions on page 49 from step 4.

## 8 Deleting an Audio/MIDI file

This function is used to delete MP3/WAV audio files or MIDI song files stored on a USB device. Once a file has been deleted from the USB device it cannot be recovered.

### 1. Entering USB playback mode

Connect a USB memory device to the USB port.

Press the PLAY/STOP button, then press the MENU  $\nabla$  button to select the "USB Recorder" function.

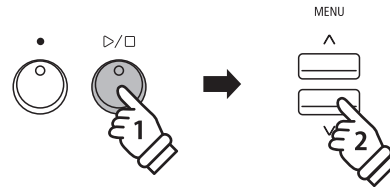

The LED indicator for the PLAY/STOP button will turn on, and the file selection screen will be shown in the display.

\* Please refer to page 50 for information about the file selection screen.

### 2. Selecting the audio/MIDI file to be deleted.

Press the  $\nabla$  or  $\wedge$  VALUE buttons to move the selection cursor, then press the MENU  $\wedge$  button to select the audio/MIDI file.

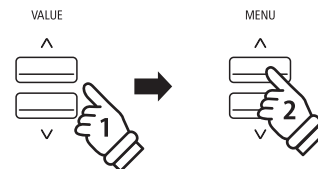

The USB player screen will be shown in the display.



### 3. Deleting the selected audio/MIDI file

Press the  $\bullet$  (REC) button and PLAY/STOP buttons simultaneously.

The LED indicators for the  $\bullet$  (REC) and PLAY/STOP buttons will start to flash, and the Delete screen will be shown in the display.

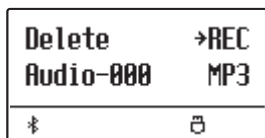
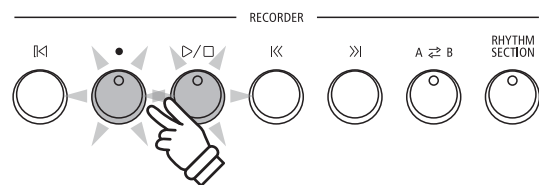

Press the  $\bullet$  (REC) button.



A confirmation message will be shown in the display, prompting to confirm or cancel the erase operation.



Press the VALUE  $\wedge$  button to confirm the erase operation and return to the Internal Song Player screen.

Press the EXIT button to cancel the erase operation.

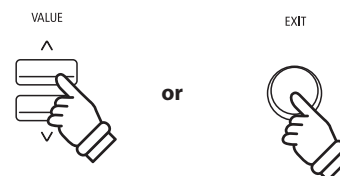

\* If cancelled, press the PLAY/STOP button to return to the Play Internal screen, or  $\bullet$  (REC) button to return to the Record Internal screen.

# USB Menu

The USB Menu contains functions to load/save registration memories and recorder songs from/to a USB memory device. This menu also allows files to be renamed and deleted, and for the USB memory device to be formatted.

## ■ USB Menu functions

Page no.	Function	Description
1	Load Int. Song	Load a song file (KSO file) from a USB memory device into the instrument's internal memory.
2	Load Regist	Load the registration file from a USB memory device into the instrument.
3	Load Startup Setting	Load a startup setting file (KM1 file) from a USB memory device into the instrument's internal memory.
4	Save SMF Song	Save the song recorded in the instrument's internal memory to a USB memory device in SMF file format.
5	Save INT Song	Save the song recorded in the instrument's internal memory to a USB memory device in KSO file format.
6	Save Regist	Save the registration set on the instrument to a USB memory device.
7	Save Startup Setting	Save the startup setting set on the instrument to a USB memory device in KM1 file format.
8	Rename File	Rename the name of a file stored in a USB memory device.
9	Delete File	Delete a file in a USB memory device.
10	Format USB	Format a USB memory device.

## 1. Entering the USB Menu

Connect a USB memory device to the USB port.

Press the USB button.

The LED indicator for the USB button will turn on, and the first page of the USB Menu will be shown in the display.



## 2. Selecting the desired USB Menu function

Press the  $\vee$  or  $\wedge$  MENU buttons to cycle through the different USB Menu function pages.

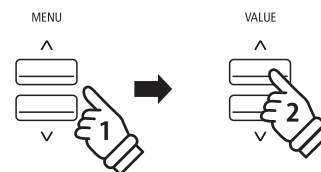

Press the VALUE  $\wedge$  button to select the function.

## 3. Exiting the USB Menu

Press the EXIT or USB button to exit the USB Menu.

The LED indicator for the USB button will turn off, and the instrument will return to normal playing mode.

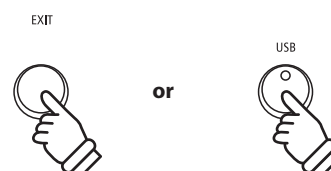

## 1 Load Internal Song

The Load Internal Song function is used to load recorder songs stored on a USB memory device into the instrument's internal memory.

### 1. Selecting the Load Int. Song function

Connect a USB memory device, then press the USB button to enter the USB Menu.

Press the  $\nabla$  or  $\wedge$  MENU buttons then the VALUE  $\wedge$  button to select the Load Int. Song function.

The file selection screen will be shown in the display, listing song files stored on the USB memory device.

\* Please refer to page 50 for information about the file selection screen.

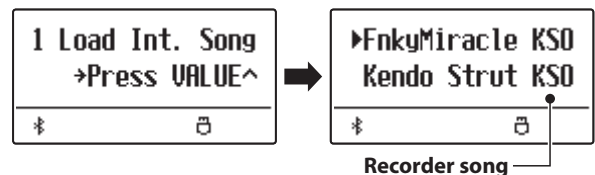

### 2. Selecting the song file to be loaded

Press the  $\nabla$  or  $\wedge$  VALUE buttons to move the selection cursor, then press the MENU  $\wedge$  button to select the song file.

The memory selection screen will be shown in the display.



### 3. Selecting the song memory

Press the  $\nabla$  or  $\wedge$  VALUE buttons to select the internal song memory for the song to be loaded into.

\* If a song memory contains song data, a \* symbol will be shown.

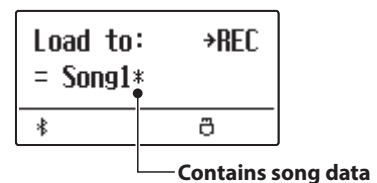

### 4. Loading the selected song

Press the ● (REC) button to load the selected song.

A confirmation message will be shown in the display.

Press the VALUE  $\wedge$  button to confirm the load operation. Press the EXIT button to cancel the load operation.

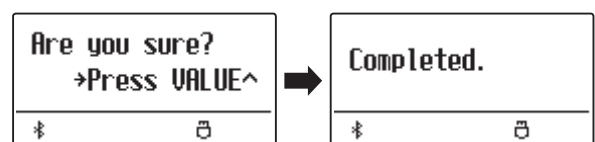

To play back the loaded song, please refer to the "Playing a Song" instructions on page 44.

# 2 Load Registration

The Load Registration function is used to load registration memories stored on a USB memory device into the instrument's internal memory. There are two types of registration file: "Single" and "All".

## Registration file types

Registration type	Description	File extension
Single	A file containing a single registration memory.	KM6
All	A file containing all 28 registration memories.	KM3

### 1. Selecting the Load Regist function

Connect a USB memory device, then press the USB button to enter the USB Menu.

Press the  $\nabla$  or  $\wedge$  MENU buttons then the VALUE  $\wedge$  button to select the Load Regist function.

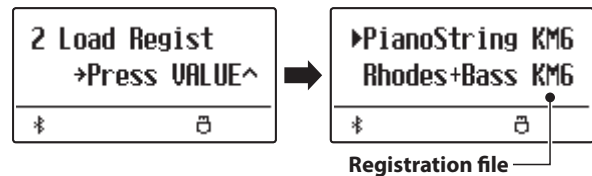

The file selection screen will be shown in the display, listing the registration files stored on the USB memory device.

\* Please refer to page 50 for information about the file selection screen.

### 2. Selecting the registration file to be loaded

Press the  $\nabla$  or  $\wedge$  VALUE buttons to move the selection cursor, then press the MENU  $\wedge$  button to select the registration file.



The memory selection screen will be shown in the display.

### 3. Selecting the registration memory

Press the  $\nabla$  or  $\wedge$  VALUE buttons to select the registration memory for the registration to be loaded into.

\* If an "All Registration" file is selected, this step will be skipped.

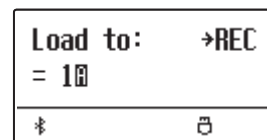

### 4. Loading the selected registration

Press the ● (REC) button to load the selected registration.

A confirmation message will be shown in the display.

Press the VALUE  $\wedge$  button to confirm the load operation.  
Press the EXIT button to cancel the load operation.

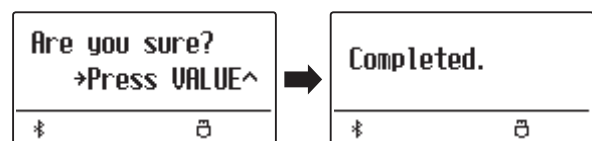

To use the loaded registration, please refer to the Registration instructions on page 36.

# 3 Load Startup Setting

The Load Startup Setting function is used to load a ES920 startup setting file stored on a USB memory device into the instrument's startup memory. The loaded settings will be used as the default settings every time the ES920 digital piano is turned on.

\* This function will overwrite the previously stored Startup Settings memory.

## 1. Selecting the Load Startup Setting function

Connect a USB memory device, then press the USB button to enter the USB Menu.

Press the  $\nabla$  or  $\wedge$  MENU buttons then the VALUE  $\wedge$  button to select the Load Startup Setting function.

The file selection screen will be shown in the display, listing the startup setting files stored on the USB memory device.

\* Please refer to page 50 for information about the file selection screen.

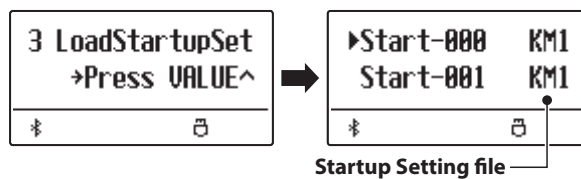

## 2. Selecting the startup setting file to be loaded

Press the  $\nabla$  or  $\wedge$  VALUE buttons to move the selection cursor, then press the MENU  $\wedge$  button to select the startup setting file.

The memory selection screen will be shown in the display.



## 3. Loading the selected startup setting

Press the  $\bullet$  (REC) button to load the selected startup setting.

A confirmation message will be shown in the display.

Press the VALUE  $\wedge$  button to confirm the load operation.  
Press the EXIT button to cancel the load operation.

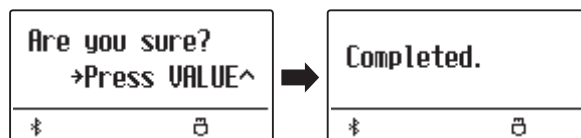

# 4 Save SMF Song

The Save SMF Song function is used to save recorder songs stored in the instrument's internal memory to a USB memory device as a Standard MIDI File (SMF).

## 1. Selecting the Save SMF Song function

Connect a USB memory device, then press the USB button to enter the USB Menu.

Press the  $\nabla$  or  $\wedge$  MENU buttons then the VALUE  $\wedge$  button to select the Save SMF Song function.

The song selection screen will be shown in the display.

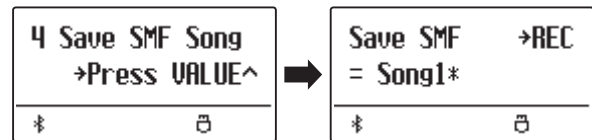

## 2. Selecting the song to be saved

Press the  $\nabla$  or  $\wedge$  VALUE buttons to select the internal song memory to be saved.

Press the ● (REC) button to continue.

The filename entry screen will be shown in the display.

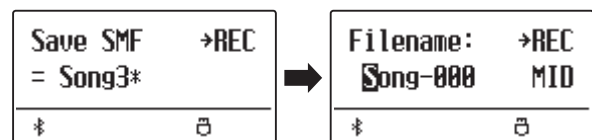

## 3. Naming the SMF song

Press the  $\nabla$  or  $\wedge$  VALUE buttons to cycle through the characters, and the  $\nabla$  or  $\wedge$  MENU buttons to move the cursor.

- \* Saved files are limited to a maximum name length of 11 characters.
- \* The saved SMF file will be stored in the root folder of the USB memory device. It is not possible to store the file in a different folder.



## 4. Saving the SMF song

Press the ● (REC) button again to save the SMF song with the specified filename.

A confirmation message will be shown in the display.

Press the VALUE  $\wedge$  button to confirm the save operation.  
Press the EXIT button to cancel the save operation.

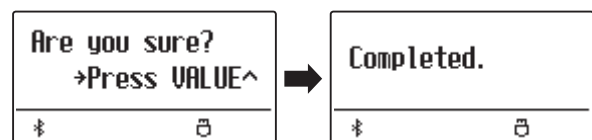

## 5 Save Internal Song

The Save Internal Song function is used to save recorder songs stored in the instrument's internal memory to a USB memory device in the ES920's native song format.

### 1. Selecting the Save Int. Song function

Connect a USB memory device, then press the USB button to enter the USB Menu.

Press the  $\vee$  or  $\wedge$  MENU buttons then the VALUE  $\wedge$  button to select the Save Int. Song function.

The song selection screen will be shown in the display.

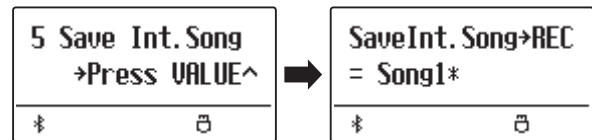

### 2. Selecting the song to be saved

Press the  $\vee$  or  $\wedge$  VALUE buttons to select the internal song memory to be saved.

Press the ● (REC) button to continue.

The filename entry screen will be shown in the display.

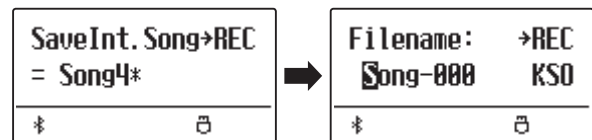

### 3. Naming the song

Press the  $\vee$  or  $\wedge$  VALUE buttons to cycle through the characters, and the  $\vee$  or  $\wedge$  MENU buttons to move the cursor.

- \* Saved files are limited to a maximum name length of 11 characters.
- \* The saved song will be stored in the root folder of the USB memory device. It is not possible to store the file in a different folder.



### 4. Saving the song

Press the ● (REC) button again to save the recorded song with the specified filename.

A confirmation message will be shown in the display.

Press the VALUE  $\wedge$  button to confirm the save operation.  
Press the EXIT button to cancel the save operation.

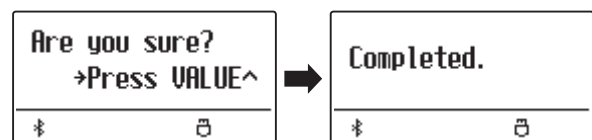

# 6 Save Registration

The Save Registration function is used to save registration memories stored in the instrument to a USB memory device. There are two types of registration file: "Single" and "All".

## Registration file types

Registration type	Description	File extension
Single	A file containing a single registration memory.	KM6
All	A file containing all 28 registration memories.	KM3

### 1. Selecting the Save Regist function

Connect a USB memory device, then press the USB button to enter the USB Menu.

Press the  $\nabla$  or  $\wedge$  MENU buttons then the VALUE  $\wedge$  button to select the Save Regist function.

The memory selection screen will be shown in the display.

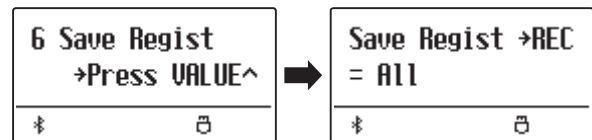

### 2. Selecting the registration memory to be saved

Press the  $\nabla$  or  $\wedge$  VALUE buttons to select the registration memory to be saved.

\* The "All" option will save all registration memories to a single file.

Press the ● (REC) button to continue.

The filename entry screen will be shown in the display.

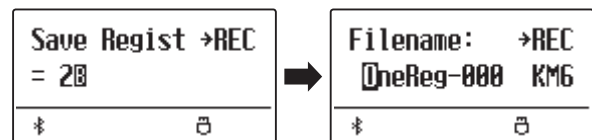

### 3. Naming the registration file

Press the  $\nabla$  or  $\wedge$  VALUE buttons to cycle through the characters, and the  $\nabla$  or  $\wedge$  MENU buttons to move the cursor.

\* Saved files are limited to a maximum name length of 11 characters.

\* The saved registration will be stored in the root folder of the USB memory device. It is not possible to store the file in a different folder.



### 4. Saving the registration file

Press the ● (REC) button again to save the recorded registration with the specified filename.

A confirmation message will be shown in the display.

Press the VALUE  $\wedge$  button to confirm the save operation.  
Press the EXIT button to cancel the save operation.

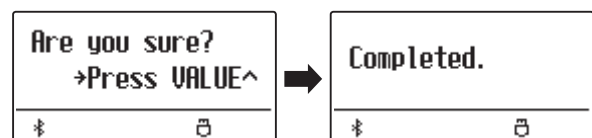

## 7 Save Startup Setting

The Save Startup Setting function is used to save the current ES920 Startup Settings to a USB memory device.

\* For more information about the instrument's "Startup Setting" feature, please refer to page 82.

### 1. Selecting the Save Startup Setting function

Connect a USB memory device, then press the USB button to enter the USB Menu.

Press the  $\nabla$  or  $\wedge$  MENU buttons then the VALUE  $\wedge$  button to select the Save Startup Setting function.

The memory selection screen will be shown in the display.

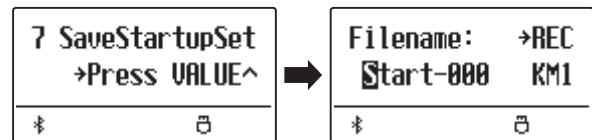

### 2. Naming the startup setting file

Press the  $\nabla$  or  $\wedge$  VALUE buttons to cycle through the characters, and the  $\nabla$  or  $\wedge$  MENU buttons to move the cursor.

\* Saved files are limited to a maximum name length of 11 characters.

\* The saved startup setting will be stored in the root folder of the USB memory device. It is not possible to store the file in a different folder.



### 3. Saving the startup setting file

Press the ● (REC) button again to save the recorded startup setting with the specified filename.

A confirmation message will be shown in the display.

Press the VALUE  $\wedge$  button to confirm the save operation.  
Press the EXIT button to cancel the save operation.

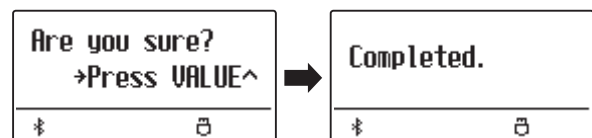

# 8 Rename File

The Rename File function is used to rename song, audio, and registration files stored on a USB memory device.

## 1. Selecting the Rename File function

Connect a USB memory device, then press the USB button to enter the USB Menu.

Press the  $\nabla$  or  $\wedge$  MENU buttons then the VALUE  $\wedge$  button to select the Rename File function.

The file selection screen will be shown in the display, listing song, audio, and registration files stored on the USB memory device.

\* Please refer to page 50 for information about the file selection screen.

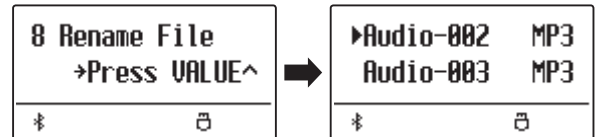

## 2. Selecting the file to be renamed

Press the  $\nabla$  or  $\wedge$  VALUE buttons to move the selection cursor, then press the MENU  $\wedge$  button to select the file.

The filename entry screen will be shown in the display.



## 3. Renaming the selected file

Press the  $\nabla$  or  $\wedge$  VALUE buttons to cycle through the characters, and the  $\nabla$  or  $\wedge$  MENU buttons to move the cursor.

\* Files are limited to a maximum name length of 11 characters.

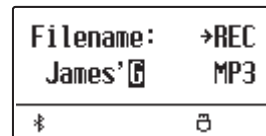

## 4. Confirming the rename

Press the ● (REC) button to rename the file.

A confirmation message will be shown in the display.

Press the VALUE  $\wedge$  button to confirm the rename operation.  
Press the EXIT button to cancel the rename operation.

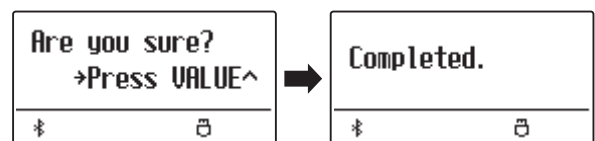

## 5. Exiting the Rename File function

Press the EXIT button to exit the Rename File function.

The LED indicator for the USB button will turn off, and the instrument will return to normal playing mode.

## 9 Delete File

The Delete File function is used to delete song, audio, and registration files stored on a USB memory device. Once a file has been deleted from the USB device it cannot be recovered.

### 1. Selecting the Delete File function

Connect a USB memory device, then press the USB button to enter the USB Menu.

Press the  $\nabla$  or  $\wedge$  MENU buttons then the VALUE  $\wedge$  button to select the Delete File function.

The file selection screen will be shown in the display, listing song, audio, and registration files stored on the USB memory device.

\* Please refer to page 50 for information about the file selection screen.

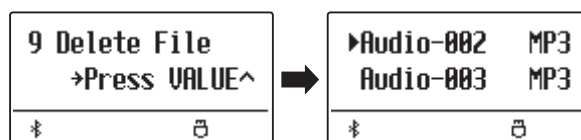

### 2. Selecting the file to be deleted

Press the  $\nabla$  or  $\wedge$  VALUE buttons to move the selection cursor, then press the MENU  $\wedge$  button to select the file.



### 3. Confirming the delete

A confirmation message will be shown in the display.

Press the VALUE  $\wedge$  button to confirm the delete operation. Press the EXIT button to cancel the delete operation.

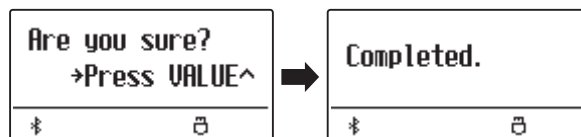

### 4. Exiting the Delete File function

Press the EXIT button to exit the Delete File function.

The LED indicator for the USB button will turn off, and the instrument will return to normal playing mode.

# 10 Format USB

The Format USB function is used to format the connected USB memory device, erasing all stored data.



**The USB Format function will erase all data stored on the connected USB memory device. Exercise caution when using this function in order to prevent accidental data loss.**

## 1. Selecting the Format USB function

Connect a USB memory device, then press the USB button to enter the USB Menu.

Press the  $\nabla$  or  $\wedge$  MENU buttons then the VALUE  $\wedge$  button to select the Format USB function.

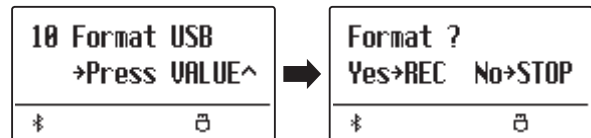

An initial confirmation message will be shown in the display.

## 2. Confirming the format operation (initial confirmation)

Press the ● (REC) button to confirm the format operation.  
Press the PLAY/STOP button to cancel the format operation.

If the ● (REC) button is pressed, a final confirmation message will be shown in the display.

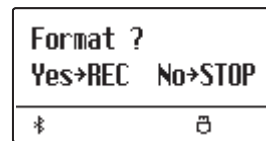

## 3. Confirming the format operation (final confirmation)

Press the VALUE  $\wedge$  button to confirm the format operation.  
Press the EXIT button to cancel the format operation.

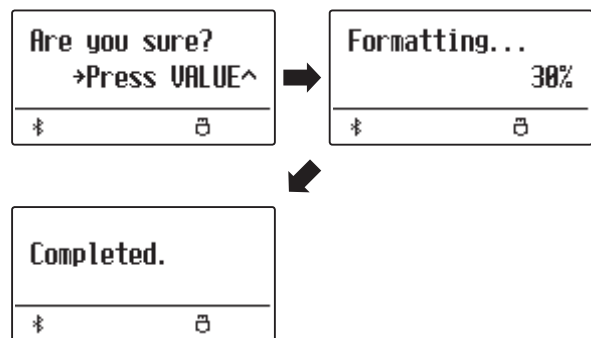

## 4. Exiting the Format USB function

Press the EXIT button to exit the Format USB function.

The LED indicator for the USB button will turn off, and the instrument will return to normal playing mode.

# Settings Menu

The Settings menus contain a variety of options to adjust the ES920's operation and sound. Settings are grouped by category, providing convenient access to relevant controls. Once adjusted, settings can be stored to one of the instrument's 28 registration memories, or selected as the default power-on settings with the Startup Setting function.

## ■ Entering the Settings menus

While the normal playing mode screen is shown in the display:

Press the √ or ^ MENU buttons.

The first settings menu (Basic Settings) will be shown in the display.



Press the √ or ^ MENU buttons to cycle through the different settings menus, then press the VALUE ^ button to enter the selected menu.

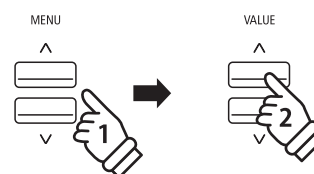
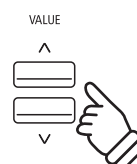

## ■ Exiting the Settings menus

Press the EXIT button to return to the main settings menu.

Press the EXIT button again to return to normal playing mode.



## ■ Overview of Settings menus

### 1. Basic Settings

Tone Control, Wall EQ, Speaker Volume, Low Volume Balance,  
Line Out Volume, Audio Rec Gain, Tuning, Damper Hold, GFP-3 Mode,  
Four Hands, Startup Setting, Factory Reset, Auto Display Off,  
Auto Power Off

### 2. Virtual Technician

Touch Curve, Voicing, User Voicing, Damper Resonance,  
Damper Noise, String Resonance, Undamped String Resonance,  
Cabinet Resonance, Key-off Effect, Fall-back Noise, Hammer Noise,  
Hammer Delay, Topboard, Decay Time, Release Time,  
Minimum Touch, Temperament, Stretch Tuning, Stretch Curve,  
User Tuning, Temperament Key, User Temperament, User Key Volume,  
Half-Pedal Adjust, Soft Pedal Depth

### 3. Key Settings

Lower Octave Shift, Lower Pedal On/Off, Split Balance,  
Layer Octave Shift, Layer Dynamics, Dual Balance

### 4. Rhythm Settings

Rhythm Volume, Auto Fill-in, One Finger Ad-lib, ACC Mode,  
Bass Inversion, Preset Chord

### 5. Phones Settings

SHS Mode, Phones Type, Phones Volume

### 6. MIDI Settings

### 7. Bluetooth Settings

Bluetooth Audio, Bluetooth Audio Volume, Bluetooth MIDI

# Basic Settings

The Basic settings menu contains settings to adjust the pitch, tuning, and general sound of the instrument. This menu also allows favourite panel settings to be stored, or reset back to the original factory configuration.

\* Any changes made by this operation will remain until the power is turned off. Preferred settings can be stored in a Registration memory or Startup Setting. Please refer to page 36 and 82 for more information.

## Basic Settings

Page no.	Setting	Description	Default setting
1-1	Tone Control	Change the EQ settings of the instrument's sound.	Flat
1-2	Wall EQ	Optimise the instrument's speaker system based on instrument placement.	Off
1-3	Speaker Volume	Change the maximum volume level of the speaker output.	Normal
1-4	Low Volume Balance	Change the difference in volume between pianissimo and fortissimo playing.	3
1-5	Line Out Volume	Specify whether the Line Out volume can be adjusted using the Master Volume slider.	Adjust by M.V.
1-6	Audio Rec Gain	Increase or decrease the recording level of the MP3/WAV audio recorder.	+9 dB
1-7	Tuning	Increase or decrease the pitch of the instrument in 0.5 Hz steps.	440.0 Hz
1-8	Damper Hold	Change the effect of pressing the sustain pedal on organ, string, etc. sounds.	Preset
1-9	GFP-3 Mode	Change the function of the optional GFP-3 or F-302 triple pedal.	Sostenuto/Soft
1-10	Four Hands	Enable the "Four Hands Mode" function.	Off
1-11	Startup Setting	Store current panel settings as the default (power-on) configuration.	-
1-12	Factory Reset	Restore all panel settings to the original factory configuration.	-
1-13	Auto Display Off	Turn off the display automatically after a period of time without any operations.	5 min.
1-14	Auto Power Off	Turn off the instrument automatically after a period of time without any operations.	-

## Entering the Basic Settings menu

While the normal playing mode screen is shown in the display:

Press the  $\nabla$  or  $\blacktriangle$  MENU buttons.

The Basic Settings page will be shown in the display.



Press the VALUE  $\blacktriangle$  button to enter the Basic Settings menu.

The first page of the Basic Settings menu will be shown in the display

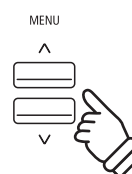

## Selecting the desired setting

After entering the Basic Settings menu:

Press the  $\nabla$  or  $\blacktriangle$  MENU buttons to cycle through the different settings pages.

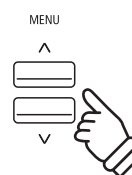
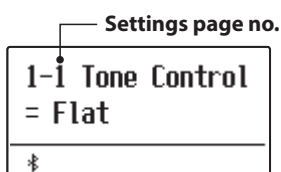

## 1-1 Tone Control

The Tone Control function allows the overall sound character of the ES920 digital piano to be adjusted to ensure the best sound quality within the area that the instrument is located. There are six different preset Tone Control types available, with an additional “User” setting allowing finer control over the different frequency bands.

\* The tone (volume) set in this function is applied to the middle position of the sliders of 4-band equalizer on the panel.

### ■ Tone Control types

Tone Control type	Description
Flat (default)	The Tone Control is turned off, and the sound character is unchanged.
Brilliance	Adjust the overall brightness of the sound, independently of the “Voicing” Virtual Technician setting.
Bass Boost	Emphasises low-range frequencies, creating a deeper sound.
Bass Cut	Reduces bass-range frequencies.
Mid Boost	Emphasises mid-range frequencies, creating a slightly hard sound.
Loudness	Emphasises frequencies to retain the instrument’s sound character when playing at low volume levels.
Bright	Emphasises dazzling brightness of the sound.
Mellow	Emphasises calm softness of the sound.
User EQ	Allows the low, mid, and high-range frequency bands to be adjusted separately.

### ■ Changing the Tone Control type

After entering the Basic Settings menu (page 73):

The Tone Control setting will be selected automatically.

Press the  $\nabla$  or  $\wedge$  VALUE buttons to cycle through the different Tone Control types.

Press the EXIT button to exit the Tone Control setting and return to the main settings menu.

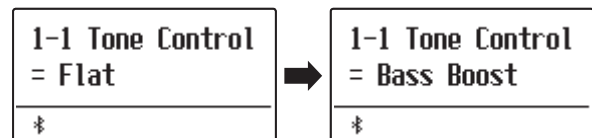

## Brilliance

The Brilliance setting allows the overall brightness of the ES920 digital piano’s sound to be adjusted, independently of the “Voicing” Virtual Technician setting.

### ■ Adjusting the Brilliance setting

After entering the Tone Control menu:

Press the  $\nabla$  or  $\wedge$  VALUE buttons to select the Brilliance setting mode.

Then press the MENU  $\wedge$  button, Brilliance setting screen will be shown in the display.

Press the  $\nabla$  or  $\wedge$  VALUE buttons to adjust the Brilliance setting.

\* Brilliance can be adjusted within the range of -10~+10.

Press the EXIT button to exit the Brilliance setting and return to the main settings menu.

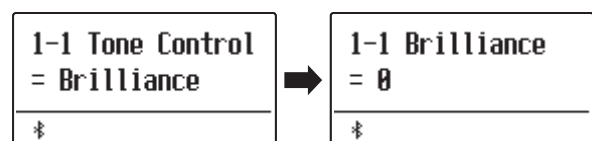

# User EQ

The User EQ option allows finer control over the instrument's sound character, allowing the volume of four frequency bands to be adjusted individually. It is also possible to adjust the frequency range of the mid-low and mid-high frequency bands.

## User EQ setting

User EQ	Description
Low	Adjusts the volume of the low range frequency band (20~100 Hz).
Mid-low Frequency	Adjusts the frequency of the mid-low band (200~8000 Hz).
Mid-high Frequency	Adjusts the frequency of the mid-high band (200~8000 Hz).
High	Adjusts the volume of the high range frequency band (5000~20000 Hz).

## Adjusting the User EQ bands (low/mid/high)

After entering the Tone Control menu:

Press the  $\nabla$  or  $\wedge$  VALUE buttons to select the User EQ setting mode.

Then press the MENU  $\wedge$  button, User EQ setting screen will be shown in the display.

Press the  $\nabla$  or  $\wedge$  MENU buttons to cycle through the different User EQ settings, then press the  $\nabla$  or  $\wedge$  VALUE buttons to adjust the value of the selected setting.

\* Frequencies set for Mid-low and Mid-high bands are applied to the second and third band equalisers from the left on the panel.

\* The volume set in this function is applied to the middle position of the sliders of 4-band equalizer.

The volume settable for each band on this instrument is from -6dB to +6dB.

When the volume is set to +6dB in User EQ, +6dB is applied at the middle of the slider on the panel; therefore, the volume will not increase even if the slider is moved above the middle.

Press the EXIT button to exit the User EQ setting and return to the main settings menu.

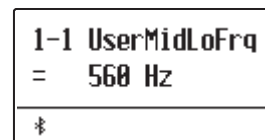
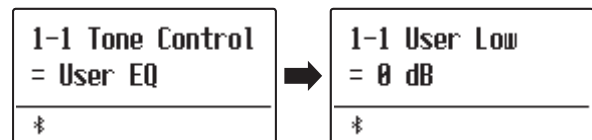

## 1-2 Wall EQ

The Wall EQ setting optimises the ES920 digital piano's speaker system depending on whether the instrument is placed beside a wall, or in an area away from a wall.

\* This setting does not affect the headphones or Line Out output.

### ■ Wall EQ settings

Wall EQ	Description
Off (default)	Optimise the speaker system for placing the ES920 digital piano in an area away from a wall.
On	Optimise the speaker for placing the ES920 digital piano beside a wall.

### ■ Changing the Wall EQ setting

After entering the Basic Settings menu (page 73):

Press the  $\nabla$  or  $\wedge$  MENU buttons to select the Wall EQ setting.

Press the  $\nabla$  or  $\wedge$  VALUE buttons to turn the Wall EQ setting on or off.

Press the EXIT button to exit the Wall EQ setting and return to the main settings menu.

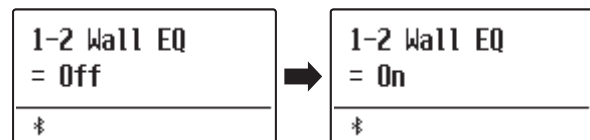

## 1-3 Speaker Volume

The Speaker Volume setting allows the maximum volume level of the ES920 digital piano's speaker output to be reduced, providing finer adjustment control over the master volume. This setting can also function as a volume limiter, preventing the instrument from being played too loudly in the home or classroom etc.

\* This setting does not affect the headphones or Line Out volume.

### ■ Speaker Volume settings

Speaker Volume	Description
Normal (default)	The instrument's speakers will output sound at the normal volume level.
Low	The instrument's speakers will output sound at a reduced volume level.

### ■ Changing the Speaker Volume setting

After entering the Basic Settings menu (page 73):

Press the  $\nabla$  or  $\wedge$  MENU buttons to select the Speaker Volume setting.

Press the  $\nabla$  or  $\wedge$  VALUE buttons to alternate between "Normal" and "Low" speaker volume settings.

Press the EXIT button to exit the Speaker Volume setting and return to the main settings menu.

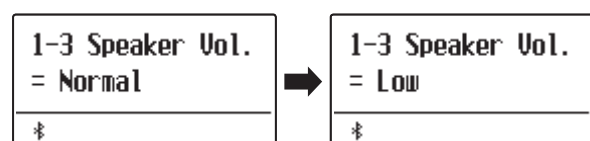

# 1-4 Low Volume Balance

The Low Volume Balance setting reduces the difference in volume between pianissimo and fortissimo touches, allowing the piano to continue to be played at low volume without the sound of pianissimo notes being lost.

## ■ Low Volume Balance settings

Low Volume Balance	Description
Off	Low Volume Balance adjustment is not applied.
1	A small amount of Low Volume Balance adjustment will be applied.
⋮	⋮
5	A large amount of Low Volume Balance adjustment will be applied.

## ■ Changing the Low Volume Balance setting

After entering the Basic Settings menu (page 73):

Press the  $\nabla$  or  $\wedge$  MENU buttons to select the Low Volume Balance setting.

Press the  $\nabla$  or  $\wedge$  VALUE buttons to turn Low Volume Balance off, or select the setting value.

Press the EXIT button to exit the Low Volume Balance setting and return to the main settings menu.

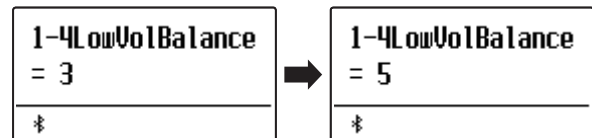

## 1-5 Line Out Volume

The Line Out Volume setting is used to determine whether the Line Out level can be adjusted using the Master Volume slider, or whether the Line Out level should be fixed. This setting may be useful when connecting the ES920 digital piano to a mixing console or PA system, while using the instrument's built-in speakers as local monitors.

\* This setting does not affect the speaker or headphone volume.

### Line Out Volume settings

Line Out Volume	Description
Adjust by M.V. (default)	The Line Out level can be adjusted using the Master Volume slider.
Fixed	The Line Out level is fixed and cannot be adjusted using the Master Volume slider.

### Changing the Line Out Volume setting

After entering the Basic Settings menu (page 73):

Press the  $\nabla$  or  $\wedge$  MENU buttons to select the Line Out Volume setting.

Press the  $\nabla$  or  $\wedge$  VALUE buttons to select from In Adjust by M.V. or Fixed.

Press the EXIT button to exit the Line Out Volume setting and return to the main settings menu.

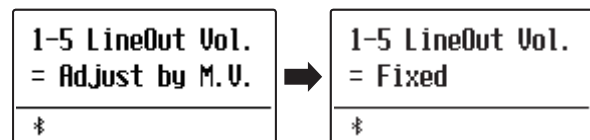

## 1-6 Audio Recorder Gain

The Audio Recorder Gain setting allows the recording level of MP3/WAV audio files to be adjusted. While the instrument's default audio recorder level is optimised to capture the broad dynamic range of a grand piano, there may be occasions where it is desirable to increase or decrease this gain setting for certain types of music.

### Adjusting the Audio Recorder Gain setting

After entering the Basic Settings menu (page 73):

Press the  $\nabla$  or  $\wedge$  MENU buttons to select the Audio Recorder Gain setting.

Press the  $\nabla$  or  $\wedge$  VALUE buttons to adjust the Audio Recorder Gain setting.

\* The Audio Recorder Gain can be adjusted within the range of 0 dB~+15 dB.

\* Increasing the Audio Recorder Gain may result in distorted recordings when playing loud/fortissimo passages.

Press the EXIT button to exit the Audio Recorder Gain setting and return to the main settings menu.

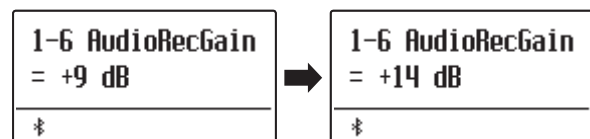

# 1-7 Tuning

The Tuning setting allows the overall pitch of the ES920 digital piano to be raised and lowered in 0.5 Hz steps, and may therefore prove useful when playing with other pitched instruments.

## ■ Adjusting the Tuning setting

After entering the Basic Settings menu (page 73):

Press the  $\nabla$  or  $\wedge$  MENU buttons to select the Tuning setting.

Press the  $\nabla$  or  $\wedge$  VALUE buttons to decrease or increase the value of the Tuning setting in 0.5 Hz steps.

\* The Tuning setting can be adjusted within the range of 427.0 Hz~453.0 Hz.

Press the EXIT button to exit the Tuning setting and return to the main settings menu.

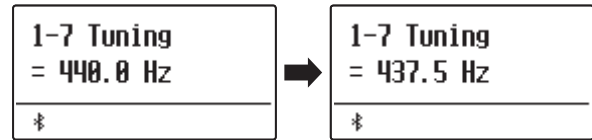

# 1-8 Damper Hold

The Damper Hold setting is used to determine whether sounds such as organ or strings should be sustained continuously when the sustain (damper) pedal is pressed, or whether these sounds should decay, naturally.

## ■ Damper Hold settings

Damper Hold	Description
Preset (default)	Organ sounds will gradually decay, even while the sustain pedal is pressed, but other String, etc. sounds will be sustained continuously while the sustain pedal is pressed.
On	Organ, string, etc. sounds will be sustained continuously while the sustain pedal is pressed.
Off	Organ, string, etc. sounds will gradually decay, even while the sustain pedal is pressed.

## ■ Changing the Damper Hold setting

After entering the Basic Settings menu (page 73):

Press the  $\nabla$  or  $\wedge$  MENU buttons to select the Damper Hold setting.

Press the  $\nabla$  or  $\wedge$  VALUE buttons to cycle through the different Damper Hold types.

Press the EXIT button to exit the Damper Hold setting and return to the main settings menu.

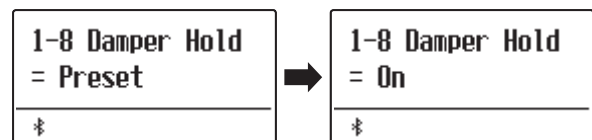

## 1-9 GFP-3 Mode

This function is used to assign a function such as starting and stopping Rhythm Section to the center and left pedals of the optional triple pedal GFP-3 or F-302.

### ■ GFP-3 Mode

GFP-3 Mode	Function assigned to the Sostenuto pedal.	Function assigned to the Soft pedal.
Default setting	Sostenuto	Soft
Fill-in/Rhythm	Fill-in	Rhythm Start/Stop
Part/Rhythm	Part toggle (All→Drum→B+Dr)	Rhythm Start/Stop
Vari./Rhythm	Variation toggle Fill-in when the pedal is pressed, and then toggle the variation of rhythm patterns.	Rhythm Start/Stop

### ■ Changing the GFP-3 mode

After entering the Basic Settings menu (page 73):

Press the  $\nabla$  or  $\wedge$  MENU buttons to select the GFP-3 Mode setting.

Press the  $\nabla$  or  $\wedge$  VALUE buttons to cycle through the different GFP-3 modes.

\* When GFP-3 mode is set to other than Sostenuto/Soft, the rotary speed cannot be switched between slow and fast using the left pedal.

Press the EXIT button to exit the GFP-3 Mode setting and return to the main settings menu.

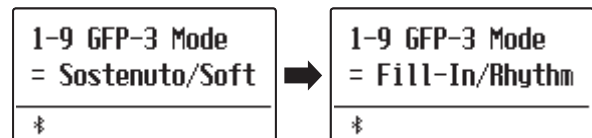

# 1-10 Four Hands

The Four Hands setting provides an alternative method to enabling the Four Hands Mode function, and may prove useful in teaching environments or situations where this function should be enabled automatically every time the ES920 digital piano is turned on.

\* Please refer to page 22 for information about the Four Hands Mode function.

## ■ Four Hands settings

Four Hands	Description
Off (default)	Four Hands Mode will be turned off by default.
On	Four Hands Mode will be turned on by default.

## ■ Changing the Four Hands setting

After entering the Basic Settings menu (page 73):

Press the  $\nabla$  or  $\wedge$  MENU buttons to select the Four Hands setting.

Press the  $\nabla$  or  $\wedge$  VALUE buttons to turn the Four Hands setting on or off.

\* When enabled, the LED indicators for the SPLIT and SOUND buttons will start to flash.

Press the EXIT button to exit the Four Hands setting and return to the main settings menu.

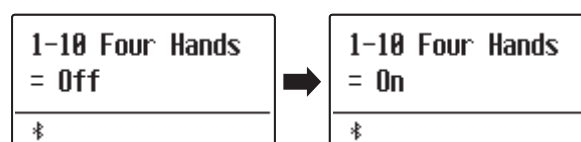

## 1-11 Startup Setting

The Startup Setting function allows preferred panel settings to be stored in the instrument's memory, and automatically recalled as the default settings every time the ES920 digital piano is turned on.

### ■ Settings stored in Startup Setting memory

General	Settings
Selected sound	Basic Settings
Dual Mode / Split Mode (sounds, volume balance, split point)	Virtual Technician
Reverb, Effects, Amp Simulator (type, settings)	Key Settings
Transpose (Key Transpose only)	Rhythm Settings
Metronome (Beat, Tempo, Volume)	MIDI Settings
	Phones Settings

\* Auto Power Off setting and Bluetooth setting are stored to Startup Setting automatically.

### ■ Storing current settings to Startup Setting memory

After entering the Basic Settings menu (page 73):

Press the  $\nabla$  or  $\wedge$  MENU buttons to select the Startup Setting function.

Press the  $\bullet$  (REC) button.

A confirmation message will be shown in the display.

Press the VALUE  $\wedge$  button to confirm the store operation.  
Press the EXIT button to cancel the store operation.

\* After storing the Startup Setting, the instrument will exit the settings menu and return to normal playing mode.

Press the EXIT button to exit the Startup Setting function and return to the main settings menu.

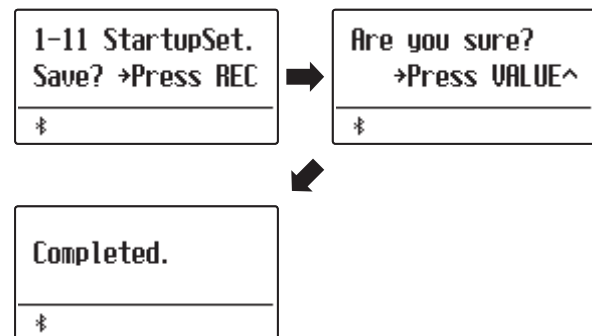

### ■ Recalling individual Startup Setting values

After selecting a setting:

Press the  $\nabla$  and  $\wedge$  VALUE buttons simultaneously.

The selected setting will be restored to the default (power on) value.

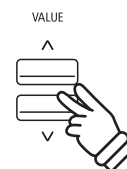

# 1-12 Factory Reset

The Factory Reset function clears any settings stored using the Startup Setting function above, restoring the ES920 digital piano back to its factory default settings.

\* This function does not clear registration memories or recorder songs stored in internal memory.

## ■ Restoring factory settings

After entering the Basic Settings menu (page 73):

Press the  $\vee$  or  $\wedge$  MENU buttons to select the Factory Reset function.

Press the  $\bullet$  (REC) button.

A confirmation message will be shown in the display.

Press the VALUE  $\wedge$  button to confirm the reset operation.

Press the EXIT button to cancel the reset operation.

\* After performing a factory reset, the instrument will exit the settings menu and return to normal playing mode.

Press the EXIT button to exit the Factory Reset function and return to the main settings menu.

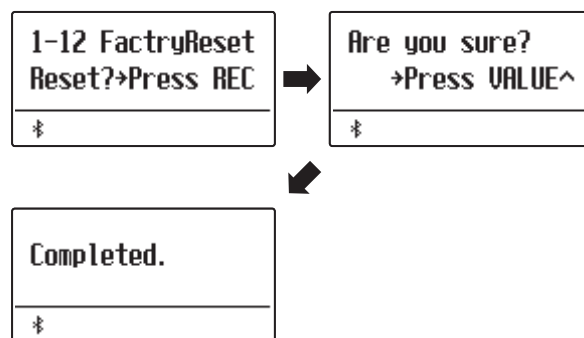

## 1-13 Auto Display Off

The Auto Display Off setting can be used to automatically turn off the display when the control panel is not being operated.

\* To prevent the ES920 digital piano's display from "burn in" as a result of showing the same screen for an extended period of time, this setting is enabled by default.

### ■ Auto Display Off settings

Auto Display Off	Description
15 sec.	The display will turn off automatically after 15 seconds of inactivity.
5 min. (default)	The display will turn off automatically after 5 minutes of inactivity.
30 min.	The display will turn off automatically after 30 minutes of inactivity.

### ■ Changing the Auto Display Off setting

After entering the Basic Settings menu (page 73):

Press the  $\nabla$  or  $\wedge$  MENU buttons to select the Auto Display Off setting.

Press the  $\nabla$  or  $\wedge$  VALUE buttons to change the Auto Display Off setting.

Press the EXIT button to exit the Auto Power Off setting and return to the main settings menu.

\* When the display turns off automatically, pressing any control panel button will turn it on again.

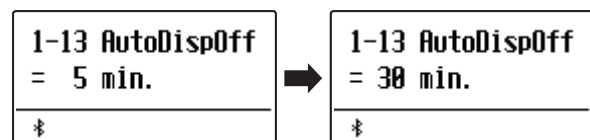

# 1-14 Auto Power Off

The Auto Power Off setting can be used to automatically turn off the instrument after a specified period of inactivity. This function may be enabled by default, depending on the market location.

## ■ Auto Power Off settings

Auto Power Off	Description
Off	The Auto Power Off function is disabled.
15 min.	The instrument will turn off automatically after 15 minutes of inactivity.
60 min.	The instrument will turn off automatically after 60 minutes of inactivity.
120 min.	The instrument will turn off automatically after 120 minutes of inactivity.

\* The default Auto Power Off setting varies depending on market location.

## ■ Changing the Auto Power Off setting

After entering the Basic Settings menu (page 73):

Press the  $\nabla$  or  $\wedge$  MENU to select the Auto Power Off setting.

Press the  $\nabla$  or  $\wedge$  VALUE buttons to change the Auto Power Off setting.

Press the EXIT button to exit the Auto Power Off setting and return to the main settings menu.

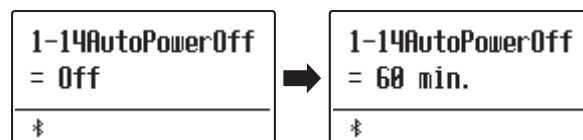

# Virtual Technician

An experienced piano technician is essential to fully realise the potential of a fine acoustic piano. In addition to meticulously tuning each note, the technician also performs numerous regulation and voicing adjustments that allow the instrument to truly sing.

The Virtual Technician settings of the ES920 digital piano simulate these refinements digitally, allowing performers to shape various aspects of the instrument's character to suit their personal preferences.

\* Any changes made by this operation will remain until the power is turned off.

Preferred settings can be stored in a Registration memory or Startup Setting. Please refer to page 36 and 82 for more information.

## Virtual Technician

Page no.	Setting	Description	Default setting
2-1	Touch Curve	Adjust the touch sensitivity of the keyboard.	Normal
2-2	Voicing	Adjust the tonal character of the instrument.	Normal
	User Voicing	Adjust the individual voicing of each of the 88 keys.	0
2-3	Damper Resonance	Adjust the resonance that is heard when pressing the damper pedal.	5
2-4	Damper Noise	Adjust the volume of the sound that is heard when pressing the damper pedal.	5
2-5	String Resonance	Adjust the resonance that is heard when notes are held.	5
2-6	Undamped Str. Res.	Adjust the resonance produced by the topmost undamped strings.	5
2-7	Cabinet Resonance	Adjust the resonance produced by the piano cabinet itself.	1
2-8	Key-off Effect	Adjust the volume of the sound that is heard when keys are released.	5
2-9	Fall-back Noise	Adjust the volume of the sound that is heard when the key action falls back.	5
2-10	Hammer Noise	Adjust the volume of the sound that is heard when hammers strike strings.	5
2-11	Hammer Delay	Adjust the delay of the hammer striking strings when playing pianissimo.	Off
2-12	Topboard	Adjust the position of the grand piano topboard.	Open 3
2-13	Decay Time	Adjust the decay time of the piano sound while the keys are pressed.	5
2-14	Release Time	Adjust the decay time of the piano sound when the keys are released.	5
2-15	Minimum Touch	Adjust the minimum key velocity required to produce a sound.	1
2-16	Temperament	Adjust the tuning system to suit Renaissance and Baroque periods etc.	Equal Temp.
	Stretch Tuning	Select how stretch tuning is applied to piano sounds and other sounds.	Piano Only
	Stretch Curve	Adjust the level of stretch tuning for equal temperaments.	Normal
	User Tuning	Adjust the individual tuning of each of the 88 keys.	0
	Temperament Key	Set the temperament key when not using equal temperament.	C
	User Temperament	Adjust the tuning of each note in the scale to a custom temperament.	0
2-17	User Key Volume	Adjust the individual volume of each of the 88 keys.	Normal
2-18	Half-Pedal Adjust	Adjust the point at which the damper pedal begins to sustain the sounds.	5
2-19	Soft Pedal Depth	Adjust the depth/effectiveness of the soft pedal.	5

## ■ Entering the Virtual Technician menu

While the normal playing mode screen is shown in the display:

Press the  $\nabla$  or  $\wedge$  MENU buttons to select the Virtual Technician menu.



Press the VALUE  $\wedge$  button to enter the Virtual Technician menu.

The first page of the Virtual Technician menu will be shown in the display

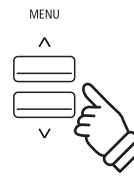

## ■ Selecting the desired setting

After entering the Virtual Technician menu:

Press the  $\nabla$  or  $\wedge$  MENU buttons to cycle through the different settings pages.

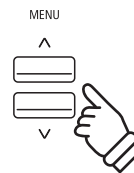
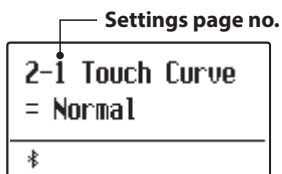

## 2-1 Touch Curve

As with an acoustic piano, the ES920 digital piano produces a louder sound when the keys are struck with force, and a softer sound when the keys are played gently. The volume and tonal character change in relation to the strength and speed of playing – on a digital piano this system is referred to as “touch sensitivity”.

The Touch Curve setting allows the touch sensitivity of the keyboard to be conveniently adjusted. There are six different preset touch curve settings available, with two additional “User” settings allowing performers to customise the instrument’s responsiveness to suit their individual playing style.

### ■ Touch Curve types

Touch Curve	Description
Heavy 4	Soft sound can be produced more evenly.
Heavy 3	Soft sound can be produced evenly.
Heavy 2	Suitable for dynamic performance with accents.
Heavy 1	Suitable for contrasting soft sound from quiet performance and bright sound from strong performance.
Normal (default)	Volume varies like acoustic pianos would responding to the touch.
Light 1	Bright sound can be produced by light touch.
Light 2	Bright sound can be produced by even lighter touch.
Light 3	Even sound can be produced by light touch.
Light 4	Suitable for young children and organ players.
Off	The same volume is sustained regardless of the strength of the touch.
User 1 / User 2	A touch curve is created to suit the user’s touch.

### ■ Changing the Touch Curve type

After entering the Virtual Technician menu (page 87):

The Touch setting will be selected automatically.

Press the  $\nabla$  or  $\wedge$  VALUE buttons to cycle through the different touch curve types.

Press the EXIT button to exit the Touch Curve setting and return to the main settings menu.

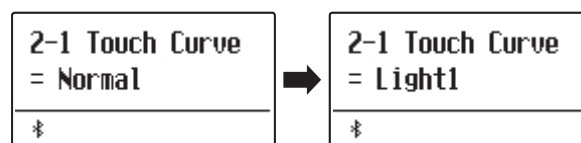

## ■ Jump to Touch Curve setting shortcut

It is also possible to access the Touch Curve setting directly while a piano sound is selected in Single Mode (i.e. not Dual Mode, Split Mode, Four Hands Mode, or Rhythm Section Mode):

Press and hold the MENU  $\vee$  or MENU  $\wedge$  buttons. The Touch Curve setting will be shown in the display.

Press the  $\vee$  or  $\wedge$  VALUE buttons to change the Touch Curve setting.

To exit the Touch Curve setting and return to the previous screen, press the EXIT button twice.

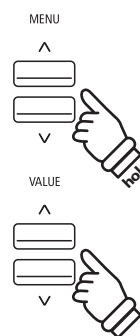

## ■ Creating a User Touch Curve

Press the  $\vee$  or  $\wedge$  VALUE buttons to select the User 1 or User 2 touch curve, then press the  $\bullet$  (REC) button.

A message will be shown in the display, prompting for the keyboard to be played.

Play the piano dynamically from very soft to very loud, allowing the instrument to examine the personal playing technique.

\* More than one attempt may be required in order to create an accurate User Touch Curve.

\* Reducing the master volume fader to the lowest position before creating the User Touch Curve may help to reduce user distractions, thus improving accuracy.

Press the PLAY/STOP button.

A confirmation message will be shown in the display.

Press the  $\bullet$  (REC) button to confirm the store operation. Press the PLAY/STOP button to cancel the store operation.

\* The user touch curve will be stored to the "User1" or "User2" touch types and selected automatically.

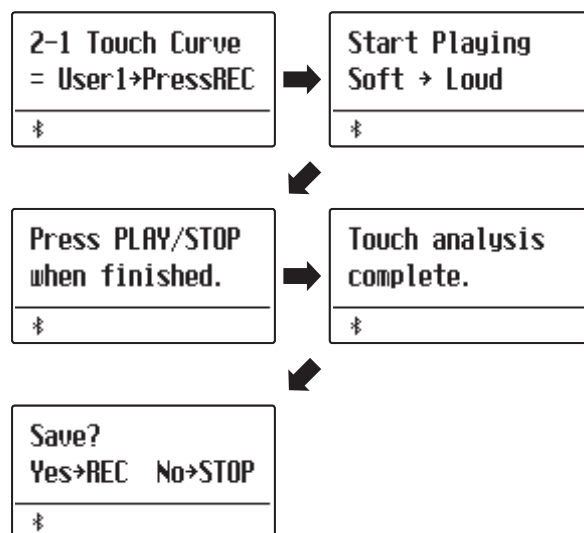

## 2-2 Voicing

On an acoustic piano, the shape, density, and texture of the hammers all influence the tonal character of the instrument's sound. Technicians utilise a variety of tools such as needles, files, and brushes to manipulate these hammer felts, with the ultimate goal of achieving a balanced tonal character across the keyboard.

The Voicing setting recreates various hammer properties, allowing the overall tonal character of the ES920 digital piano to be adjusted. There are six different preset voicing settings available (applied uniformly to all keys), with an additional four "User" settings that allow players to perform custom adjustments on each individual key.

While the default "Normal" voicing setting should be appropriate for a broad range of musical genres, it may be desirable to select a softer, more mellow tonal character for romantic pieces, or a brighter, more aggressive tone for modern styles.

\* This Virtual Technician setting will affect all sounds.

### Voicing types

Voicing type	Description
Normal (default)	The normal tonal character of an acoustic piano throughout the entire dynamic range.
Mellow 1	A softer, more mellow tonal character throughout the entire dynamic range.
Mellow 2	An even softer tonal character than Mellow 1.
Dynamic	A tonal character that changes dramatically from mellow to bright, depending on the strength of key strike.
Bright 1	A bright tonal character throughout the entire dynamic range.
Bright 2	An even brighter tonal character than Bright 1.
User 1~4	A custom tonal character, allowing each key to be individually voiced.

### Changing the Voicing type

After entering the Virtual Technician menu (page 87):

Press the  $\nabla$  or  $\wedge$  MENU buttons to select the Voicing setting.

Press the  $\nabla$  or  $\wedge$  VALUE buttons to cycle through the different voicing types.

Press the EXIT button to exit the Voicing setting and return to the main settings menu.

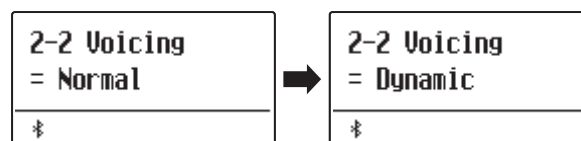

# User Voicing

The User Voicing function allows each of the 88 keys to be voiced individually.

## ■ Selecting the note, adjusting the user voicing value

After selecting the Voicing setting (page 90):

Press the  $\nabla$  or  $\wedge$  VALUE buttons to select one of the User Voicing memories.

\* Up to four different User Voicing memories can be created and stored.

Press the ● (REC) button.

The User Voicing screen will be shown in the display.

Press the desired key to be tuned, then press the  $\nabla$  or  $\wedge$  VALUE buttons to set the desired voicing value.

The desired key can also be selected by pressing the  $\nabla$  or  $\wedge$  MENU buttons.

\* The User Voicing value can be adjusted within the range of -5~+5, with lower values creating a mellower sound and higher values creating a brighter sound.

Press the STOP button to exit the User Voicing setting and return to the Voicing setting.

\* User Voicing settings are automatically saved and the settings are still effective after restarting the instrument.

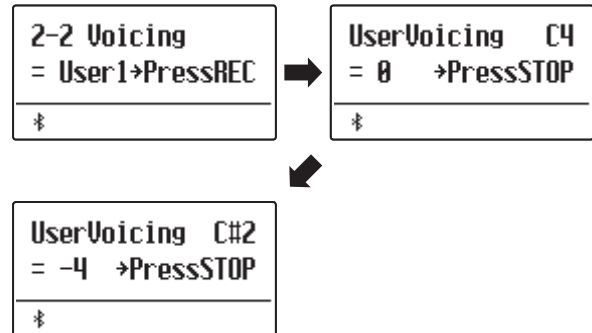

## 2-3 Damper Resonance

Pressing the damper pedal of an acoustic piano raises all dampers, allowing the strings to vibrate freely. When a note or chord is played on the piano with the sustain pedal pressed, not only will the strings of the notes played vibrate, but also the strings of other notes, vibrating in sympathetic resonance.

The ES920 digital piano recreates this phenomenon, with the Damper Resonance setting allowing the volume of this resonance sound to be adjusted.

\* This Virtual Technician setting will affect acoustic piano sounds only.

### ■ Adjusting the Damper Resonance volume

After entering the Virtual Technician menu (page 87):

Press the  $\nabla$  or  $\wedge$  MENU buttons to select the Damper Resonance setting.

Press the  $\nabla$  or  $\wedge$  VALUE buttons to adjust the volume of the Damper Resonance setting.

\* The Damper Resonance volume can be adjusted within the range of Off, 1~10, with higher values resulting in a more pronounced resonance.

Press the EXIT button to exit the Damper Resonance setting and return to the main settings menu.

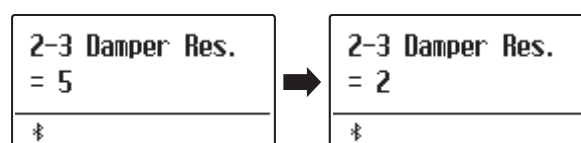

## 2-4 Damper Noise

When the damper pedal of an acoustic piano is pressed and released, it is often possible to hear the sound of the damper head touching and releasing the strings.

The ES920 digital piano reproduces this sound, with the Damper Noise setting allowing the volume of this sound to be adjusted. The speed at which the damper pedal is pressed will also influence the prominence of the damper noise, with fast pedalling creating a very pronounced sound.

\* This Virtual Technician setting will affect acoustic piano sounds only.

### ■ Adjusting the Damper Noise volume

After entering the Virtual Technician menu (page 87):

Press the  $\nabla$  or  $\wedge$  MENU buttons to select the Damper Noise setting.

Press the  $\nabla$  or  $\wedge$  VALUE buttons to adjust the volume of the Damper Noise setting.

\* The Damper Noise volume can be adjusted within the range of Off, 1~10, with higher values resulting in a more pronounced noise.

Press the EXIT button to exit the Damper Noise setting and return to the main settings menu.

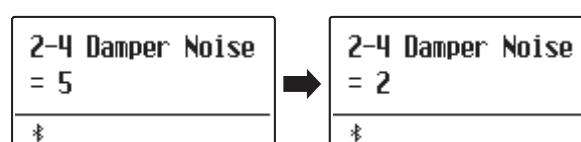

## 2-5 String Resonance

String Resonance refers to a phenomenon that exists in acoustic pianos whereby the strings of held notes resonate “sympathetically” with other notes of the same harmonic overtone series.

The ES920 digital piano recreates this phenomenon, with the String Resonance setting allowing the volume of this resonance to be adjusted.

\* This Virtual Technician setting will affect acoustic piano sounds only.

### ■ Demonstrating String Resonance

To experience the string resonance phenomenon, gently hold down the “C” key as shown in the illustration below, then press any of the keys marked with a ● symbol. In addition to the sound of each note played, it should also be possible to hear the strings of the first “C” key resonating “sympathetically”, thus demonstrating String Resonance.

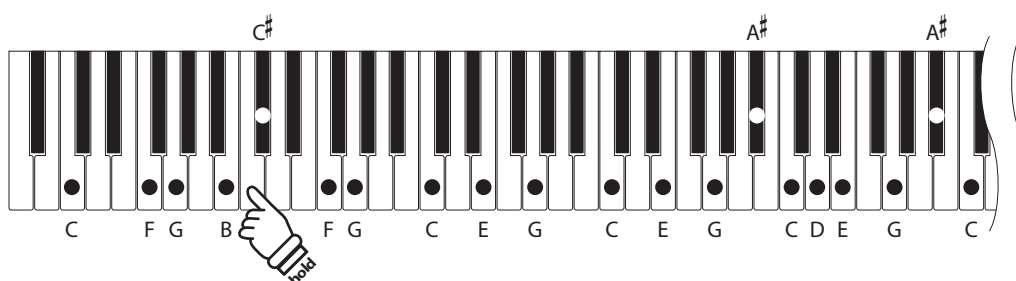

### ■ Adjusting the String Resonance volume

After entering the Virtual Technician menu (page 87):

Press the ∨ or ∧ MENU buttons to select the String Resonance setting.

Press the ∨ or ∧ VALUE buttons to adjust the volume of the String Resonance setting.

\* The String Resonance volume can be adjusted within the range of Off, 1~10, with higher values resulting in a more pronounced resonance.

Press the EXIT button to exit the String Resonance setting and return to the main settings menu.

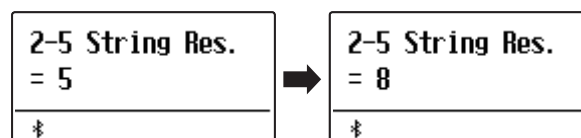

## 2-6 Undamped String Resonance

The dampers of an acoustic piano span almost the full width of the keyboard. However, the topmost 18 keys (approximately 1.5 octaves) do not incorporate dampers, as the shorter strings for these treble notes decay quickly and therefore do not need to be dampened.

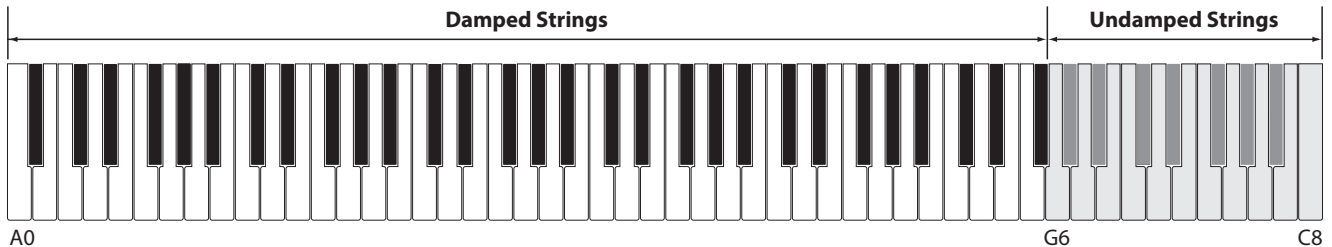

As a result, the strings of these “undamped” treble notes are free to vibrate in sympathetic resonance with those of lower keys – independently of the damper pedal position – helping to enrich the sound with additional harmonics and tonal colour.

The ES920 digital piano recreates this phenomenon, with the Undamped String Resonance setting allowing the volume of this resonance sound to be adjusted.

\* This Virtual Technician setting will affect acoustic piano sounds only.

### ■ Adjusting the Undamped String Resonance volume

After entering the Virtual Technician menu (page 87):

Press the  $\nabla$  or  $\wedge$  MENU buttons to select the Undamped String Resonance setting.

Press the  $\nabla$  or  $\wedge$  VALUE buttons to increase or decrease the volume of the Undamped String Resonance setting.

\* The Undamped String Resonance volume can be adjusted within the range of Off, 1~10, with higher values resulting in a more pronounced resonance.

Press the EXIT button to exit the Undamped String Resonance setting and return to the main settings menu.

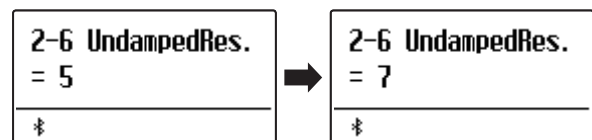

## 2-7 Cabinet Resonance

While the fundamental sound of an acoustic piano is produced by vibrating strings, transmitting energy through a spruce soundboard, the cabinet of the instrument itself also contributes a variety of subtle tonal characteristics that enrich the playing and listening experience. The keybed, inner and outer rim, iron plate, and beams all play a role in disseminating sound energy, which in turn gives the piano a living, breathing quality.

The ES920 digital piano recreates these natural acoustic characteristics, with the Cabinet Resonance setting allowing the volume of this resonance sound to be adjusted.

\* This Virtual Technician setting will affect acoustic piano sounds only.

### ■ Adjusting the Cabinet Resonance volume

After entering the Virtual Technician menu (page 87):

Press the  $\nabla$  or  $\wedge$  MENU buttons to select the Cabinet Resonance setting.

Press the  $\nabla$  or  $\wedge$  VALUE buttons to increase or decrease the volume of the Cabinet Resonance setting.

\* The Cabinet Resonance volume can be adjusted within the range of Off, 1~10, with higher values resulting in a more pronounced resonance.

Press the EXIT button to exit the Cabinet Resonance setting and return to the main settings menu.

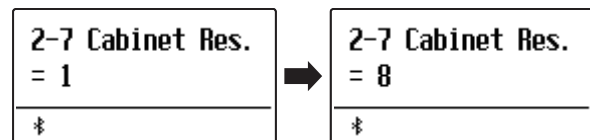

## 2-8 Key-off Effect

When playing an acoustic piano – particularly in the bass region of the keyboard – if a key is played with force and released quickly, it is often possible to hear the faint sound of the damper touching the strings immediately before the vibrations are stopped.

In addition, the speed at which keys are lifted will also affect the character of the sound. For example, when lifting the keys quickly (e.g. staccato playing) the “release” portion of the sound will be noticeably shorter than when lifting the keys slowly (e.g. legato playing).

The ES920 digital piano reproduces both characteristics, with the Key-off Effect setting allowing the volume of the key-off sound to be adjusted, and the key-off release speed detection to be turned on or off.

\* This Virtual Technician setting will affect acoustic piano, Classic E.P., Classic E.P.2, Classic E.P.3, 60's E.P., 60's E.P.2, Harpsichord, Clavi, Wood Bass, and W. Bass & Ride sounds.

### ■ Adjusting the Key-off Effect volume

After entering the Virtual Technician menu (page 87):

Press the  $\nabla$  or  $\wedge$  MENU buttons to select the Key-off Effect setting.

Press the  $\nabla$  or  $\wedge$  VALUE buttons to adjust the volume of the Key-off Effect setting.

\* The Key-off Effect volume can be adjusted within the range of Off, 1~10, with higher values resulting in a more pronounced effect.

\* When the Key-off Effect setting is set to Off, the key-off release speed detection will also be disabled, and the speed at which keys are lifted will not affect the character of the sound.

Press the EXIT button to exit the Key-off Effect setting and return to the main settings menu.

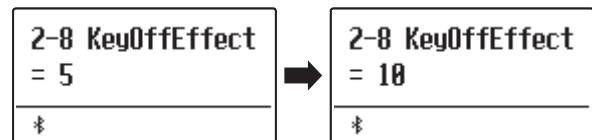

## 2-9 Fall-back Noise

When playing an acoustic piano, it is often possible to hear the faint sound of the keyboard action returning (i.e. “falling back”) to the neutral position after a key is released.

The ES920 digital piano reproduces this sound, with the Fall-back Noise setting allowing the volume of this sound to be adjusted.

While the default value is intended to simulate the natural volume level of the keys as they return to their neutral position, it may occasionally be desirable to adjust the volume of this sound. For example, reducing the volume when playing very soft pieces, where the fall-back noise may become too prominent.

\* This Virtual Technician setting will affect acoustic piano sounds only.

### ■ Adjusting the Fall-back Noise volume

After entering the Virtual Technician menu (page 87):

Press the  $\nabla$  or  $\wedge$  MENU buttons to select the Fall-back Noise setting.

Press the  $\nabla$  or  $\wedge$  VALUE buttons to adjust the volume of the Fall-back Noise setting.

\* The Fall-back Noise volume can be adjusted within the range of Off, 1~10, with higher values resulting in a more pronounced noise.

Press the EXIT button to exit the Fall-back Noise setting and return to the main settings menu.

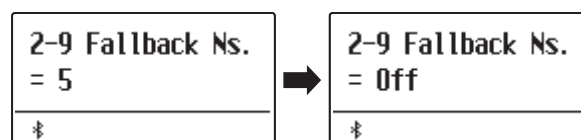

## 2-10 Hammer Noise

Acoustic pianos produce the sound when the hammers are hitting strings and the keys are hitting the key bed. This function is used to adjust the volume of these sounds.

\* This Virtual Technician setting will affect acoustic piano sounds only.

### ■ Adjusting the Hammer Noise volume

After entering the Virtual Technician menu (page 87):

Press the  $\nabla$  or  $\wedge$  MENU buttons to select the Hammer Noise setting.

Press the  $\nabla$  or  $\wedge$  VALUE buttons to adjust the volume of the Hammer Noise setting.

\* The Hammer Noise volume can be adjusted within the range of Off, 1~10, with higher values resulting in a more pronounced noise.

Press the EXIT button to exit the Hammer Noise setting and return to the main settings menu.

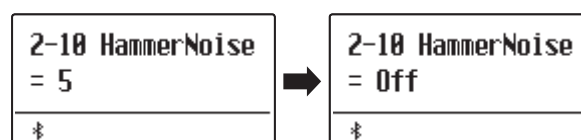

## 2-11 Hammer Delay

When playing pianissimo passages using an acoustic piano, there may be a perceived delay between a key being pressed and the hammer striking the strings.

If desired, the ES920 digital piano can recreate this delay, with the Hammer Delay setting allowing the delay length to be adjusted.

While the default value of "Off" is intended to replicate a well-regulated concert grand piano, with an immediate connection between the keyboard and hammers, some players may find it desirable to introduce a minor delay, in order to mimic different types of piano or instruments with a slightly worn keyboard action.

\* This Virtual Technician setting will affect acoustic piano sounds only.

### ■ Adjusting the Hammer Delay value

After entering the Virtual Technician menu (page 87):

Press the  $\vee$  or  $\wedge$  MENU buttons to select the Hammer Delay setting.

Press the  $\vee$  or  $\wedge$  VALUE buttons to adjust the value of the Hammer Delay setting.

\* The Hammer Delay value can be adjusted within the range of Off, 1~10, with higher values resulting in an increased delay.

Press the EXIT button to exit the Hammer Delay setting and return to the main settings menu.



## 2-12 Topboard

When playing an acoustic grand piano, the position of the instrument's topboard (lid) affects both the volume and "openness" of the tone produced. A fully open topboard allows sound waves to reflect off the polished lid surface and project into the room, while a closed lid has the opposite effect, resulting in a darker, more opaque tone.

The ES920 digital piano attempts to simulate these characteristics, with four different topboard positions.

\* This Virtual Technician setting will affect acoustic piano sounds only.

### ■ Topboard positions

Topboard position	Description
Open3 (default)	Simulates the character of a fully open topboard, with maximum sound projection.
Open2	Simulates the character of a half open topboard, with reduced sound projection.
Open1	Simulates the character of a partially open topboard, with limited sound projection.
Closed1	Simulates the character of a closed rear topboard, but open front topboard, with limited sound projection.
Closed2	Simulates the character of a closed rear topboard and closed front topboard, with minimum sound projection.

### ■ Changing the Topboard position

After entering the Virtual Technician menu (page 87):

Press the  $\nabla$  or  $\wedge$  MENU buttons to select the Topboard setting.

Press the  $\nabla$  or  $\wedge$  VALUE buttons to cycle through the different Topboard types.

Press the EXIT button to exit the Topboard setting and return to the main settings menu.

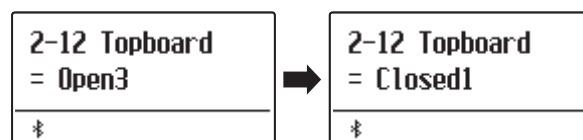

## 2-13 Decay Time

When playing an acoustic grand piano, the length of the instrument influences the speed at which held notes decay, with longer grand pianos (i.e. longer strings) characterised by longer decay times.

The ES920 digital piano attempts to simulate this characteristic, with the Decay Time setting allowing the length of decay while keys are pressed to be adjusted.

\* This Virtual Technician setting will affect all sounds.

### ■ Adjusting the Decay Time volume

After entering the Virtual Technician menu (page 87):

Press the  $\nabla$  or  $\wedge$  MENU buttons to select the Decay Time setting.

Press the  $\nabla$  or  $\wedge$  VALUE buttons to adjust the volume of the Decay Time setting.

\* The Decay Time volume can be adjusted within the range of 1~10, with larger values resulting in increased decay times.

\* The Decay Time setting can be set independently for each sound.

Press the EXIT button to exit the Decay Time setting and return to the main settings menu.

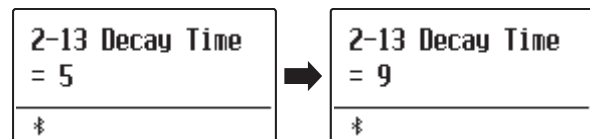

## 2-14 Release Time

When playing an acoustic grand piano, the length of the instrument also influences the speed at which played (and released) notes decay, with longer grand pianos (i.e. longer strings) characterised by longer release times.

The digital piano simulates this characteristic, with the Release Time setting allowing the length of decay after keys are released to be adjusted.

### ■ Adjusting the Release Time volume

After entering the Virtual Technician menu (page 87):

Press the  $\nabla$  or  $\wedge$  MENU buttons to select the Release Time setting.

Press the  $\nabla$  or  $\wedge$  VALUE buttons to adjust the volume of the Release Time setting.

Press the EXIT button to exit the Release Time setting and return to the main settings menu.

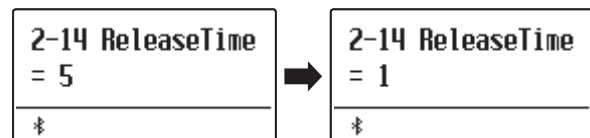

## 2-15 Minimum Touch

The Minimum Touch setting allows the minimum key velocity required to produce a sound to be adjusted. By default, this setting attempts to recreate the extremely fine touch sensitivity of a concert grand piano, allowing a very soft sound to be produced with the slightest of key touches. However, it may be desirable to reduce this sensitivity, when wishing to recreate the feeling of a small grand piano or an upright piano.

\* This Virtual Technician setting will affect acoustic piano sounds and E.PIANO (excluding Modern E.P.)

### ■ Adjusting the Minimum Touch volume

After entering the Virtual Technician menu (page 87):

Press the  $\nabla$  or  $\wedge$  MENU buttons to select the Minimum Touch setting.

Press the  $\nabla$  or  $\wedge$  VALUE buttons to adjust the volume of the Minimum Touch setting.

\* The Minimum Touch volume can be adjusted within the range of 1~20, with larger values requiring greater key force in order to produce a sound. For example, a value of 10 will require the keyboard to be played with a velocity of 10 or above in order to produce a sound.

Press the EXIT button to exit the Minimum Touch setting and return to the main settings menu.

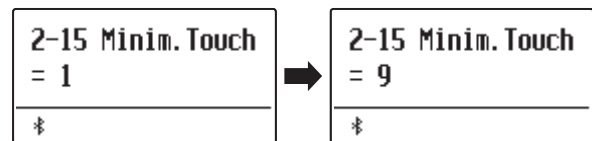

## 2-16 Temperament

The Temperament setting allows the tuning system used by the ES920 digital piano to be changed from the modern “Equal Temperament” standard to one of the various temperaments popularised during the Renaissance and Baroque periods. It is also possible to create customised temperaments using the User Temperaments function.

### ■ Temperament types

Temperament type	Description
Equal Temperament (default) (Equal)	This temperament is the most popular tuning method, and divides the scale into twelve equal semi-tones. This produces the same chordal intervals in all twelve keys, and has the advantage of limitless modulation of the key. However, the tonality of each key becomes less characteristic and no chord is in pure consonance.
Pure Temperament (Pure Major/Pure Minor)	This temperament, which eliminates dissonances for thirds and fifths, is still popular in choral music because of its perfect harmony. Any key modulation will result in dissonances. * The key of the temperament, and major/minor setting must be correctly matched.
Pythagorean Temperament (Pythagorean)	This temperament, which uses mathematical ratios to eliminate dissonance for fifths, is very limited for use with chords, but produces very characteristic melodic lines.
Meantone Temperament (Meantone)	This temperament, which uses a mean between a major and minor whole tone to eliminate dissonance for thirds, was devised to eliminate the lack of consonances experienced with certain fifths for the Mersenne pure temperament. It produces chords that are more beautiful than those played with equal temperament.
Werckmeister Temperament (Werckmeister) Kirnberger Temperament (Kirnberger)	These two temperaments are placed in between Meantone and Pythagorean. For music with few accidentals, this temperament produces the beautiful chords of the mean tone, but as accidentals increase, the temperament produces the characteristic melodies of the Pythagorean temperament. It is used primarily for classical music written in the Baroque era to revive the original characteristics.
User Temperament (User)	A custom temperament, created by raising or lowering the pitch of each note in the scale.

### ■ Changing the Temperament type

After entering the Virtual Technician menu (page 87):

Press the  $\vee$  or  $\wedge$  MENU buttons to select the Temperament setting.

Press the  $\vee$  or  $\wedge$  VALUE buttons to cycle through the different temperament types.

Press the EXIT button to exit the Temperament setting and return to the main settings menu.

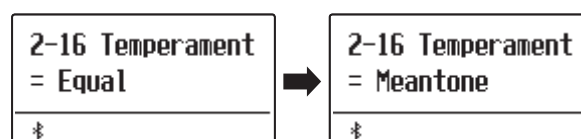

# Stretch Tuning

The Stretch Tuning setting specifies whether stretch tuning should be applied for acoustic piano sounds only, all sounds, or disabled entirely.

Stretch tuning is a piano-specific tuning method used by acoustic piano technicians in which the lower octaves are tuned slightly flatter and the upper octaves are tuned slightly sharper to match the natural harmonics of an acoustic piano.

\* This setting is only effective when Temperament is set to Equal Temperament.

## ■ Stretch Tuning setting

Stretch Tuning	Description
Piano Only (default)	Stretch tuning is applied to acoustic piano sounds only.
Off	Stretch tuning is disabled.
On	Stretch tuning is applied to all sounds.

## ■ Selecting the Stretch Tuning type

After selecting the Equal Temperament type (page 102):

Press the  $\nabla$  or  $\wedge$  MENU buttons to select the Stretch Tuning setting.

Press the  $\nabla$  or  $\wedge$  VALUE buttons to cycle through the Stretch Tuning setting.

Press the EXIT button to exit the Stretch Tuning setting and return to the main settings menu.

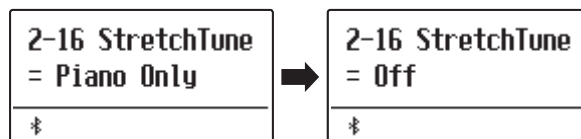

## Stretch Curve

The Stretch Curve setting specifies the degree of stretch tuning to be applied to the sound. It is also possible to create custom tuning methods using one of the four User Tuning types.

\* This setting is only effective when Stretch Tuning is set to On/Piano Only, and Temperament is set to Equal Temperament.

### ■ Stretch Curve setting

Stretch Curve	Description
Normal (default)	Normal stretch tuning.
Wide	Wide stretch tuning.
User 1~4	User defined tuning methods.

### ■ Selecting the Stretch Curve type

After entering the Virtual Technician menu (page 87):

Press the  $\nabla$  or  $\wedge$  MENU buttons to select the Stretch Curve setting.

Press the  $\nabla$  or  $\wedge$  VALUE buttons to cycle through the different Stretch Curve types.

Press the EXIT button to exit the Stretch Curve setting and return to the main settings menu.

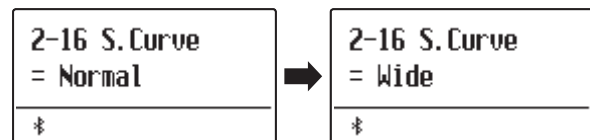

## User Tuning

The User Tuning function allows each of the 88-keys to be tuned individually.

\* This function is only effective when Stretch Tuning is set to On/Piano Only, Temperament is set to Equal Temperament, and Stretch Curve is set to User 1~4.

### ■ Selecting the note, adjusting the user tuning value

After selecting the Stretch Curve setting (page 104):

Press the  $\nabla$  or  $\wedge$  VALUE buttons to select one of the User Tuning memories.

\* Up to four different User Tuning memories can be created and stored.

Press the ● (REC) button.

The User Tuning screen will be shown in the display.

Press the desired key to be tuned, then press the  $\nabla$  or  $\wedge$  VALUE buttons to set the desired tuning value.

The desired key can also be selected by pressing the  $\nabla$  or  $\wedge$  MENU buttons.

\* The User Tuning value can be adjusted within the range of -50~+50.

Press the STOP button to exit the User Tuning setting and return to the Stretch Curve setting.

\* The User Tuning settings are saved automatically.

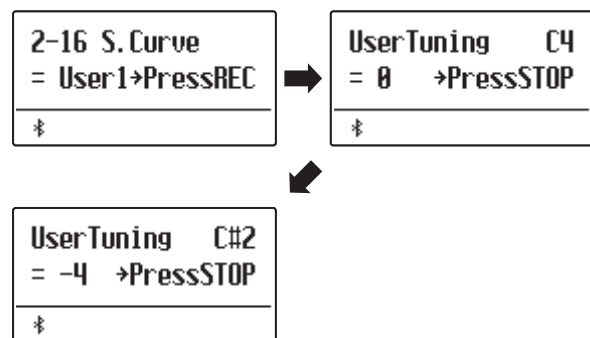

## Temperament Key

The Temperament Key setting allows the key of the selected temperament to be specified. When using a temperament other than Equal temperament, use this setting to specify the key signature of the piece.

\* This setting will only affect the “balance” of the tuning system, the pitch of the keyboard will remain unchanged.

### ■ Changing the Temperament Key setting

After selecting a temperament **other than** Equal temperament types:

Press the  $\vee$  or  $\wedge$  MENU buttons to select Temperament Key setting.

Press the  $\vee$  or  $\wedge$  VALUE buttons to select the desired temperament key.

\* The temperament key can be set within the range of C to B.

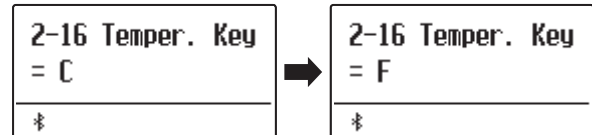

## User Temperament

The User Temperament setting allows custom temperaments to be created.

\* This setting is only available when User Temperament is selected.

### ■ Selecting the note, adjusting the user temperament value

After selecting the User Temperament type (page 104):

Press the MENU  $\wedge$  button.

Press the  $\vee$  or  $\wedge$  MENU buttons to select the desired note to be adjusted.

Press the  $\vee$  or  $\wedge$  VALUE to adjust the cent value for the selected note.

\* The User Temperament value can be adjusted within the range of -50~+50.

Press the EXIT button to exit the User Temperament setting and return to the main settings menu.

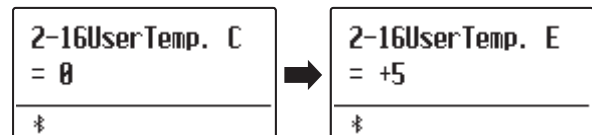

# 2-17 User Key Volume

The User Key Volume settings allows the volume of each of the 88-keys to be adjusted individually.

## ■ Selecting the note, adjusting the User Key Volume

After entering the Virtual Technician menu (page 87):

Press the  $\nabla$  or  $\wedge$  MENU buttons to select the User Key Volume setting.

Press the  $\nabla$  or  $\wedge$  VALUE buttons to select the User Key Volume memories.

\* Up to four different User Key Volume memories can be created and stored.

Press the ● (REC) button to adjust the User Key Volume memory.

Press the desired key to be adjusted, then press the  $\nabla$  or  $\wedge$  VALUE buttons to select the desired volume value.

The desired key can also be selected by pressing the  $\nabla$  or  $\wedge$  MENU buttons.

\* The User Key Volume setting can be set independently for each sound.

Press the STOP button to exit the User Key Volume setting and return to the User Key Volume memories selection.

\* The User Key Volume settings are saved automatically.

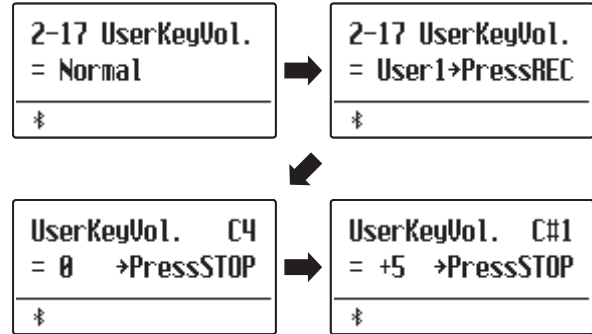

## 2-18 Half-Pedal Adjust

The Half-Pedal Adjust setting allows the point at which the damper/sustain pedal becomes effective (i.e. when the dampers of the piano begin to lift from the strings) to be adjusted. This setting may be useful for pianists that habitually rest their right foot on the damper/sustain pedal, but do not necessarily wish to sustain the sound.

\* This Virtual Technician setting will affect all sounds.

### ■ Half-Pedal Adjust settings

Half-Pedal Adjust	Description
1	This setting allows the half-pedal to start at the earliest point.
⋮	⋮
7	This setting allows the half-pedal to start at the latest point.
8	This setting allows the damper pedal to be used as the controller. Control can be done when the pedal is pressed slightly.
⋮	⋮
10	This setting allows the damper pedal to be used as the controller. Control can be done in the widest range.

### ■ Adjusting the Half-Pedal Adjust volume

After entering the Virtual Technician menu (page 87):

Press the  $\checkmark$  or  $\wedge$  MENU buttons to select the Half-Pedal Adjust setting.

Press the  $\checkmark$  or  $\wedge$  VALUE buttons to adjust the volume of the Half-Pedal Adjust setting.

\* The Half-Pedal Adjust volume can be adjusted within the range of 1~10.

Press the EXIT button to exit the Half-Pedal Adjust setting and return to the main settings menu.



## 2-19 Soft Pedal Depth

The Soft Pedal Depth setting adjusts the effectiveness (i.e. depth/strength) of the soft pedal.

\* This Virtual Technician setting will affect all sounds.

### ■ Adjusting the Soft Pedal Depth volume

After entering the Virtual Technician menu (page 87):

Press the  $\checkmark$  or  $\wedge$  MENU buttons to select the Soft Pedal Depth setting.

Press the  $\checkmark$  or  $\wedge$  VALUE buttons to adjust the volume of the Soft Pedal Depth setting.

\* The Soft Pedal Depth volume can be adjusted within the range of 1~10, with higher values resulting in a softer sound.

Press the EXIT button to exit the Soft Pedal Depth setting and return to the main settings menu.

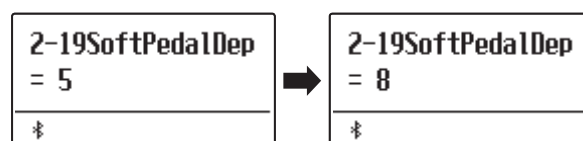

# Key Settings

The Key Settings menu contains settings to adjust the instrument's operation when using the Dual or Split playing modes.

\* Any changes made by this operation will remain until the power is turned off.  
Preferred settings can be stored in a Registration memory or Startup Setting. Please refer to page 36 and 82 for more information.

## ■ Key Settings

Page no.	Setting	Description	Default setting
3-1	Lower Octave	Raise the pitch of the lower section in octave steps when using Split mode.	0
3-2	Lower Pedal	Enable/disable sustain pedal for the lower section when using Split mode.	Off
3-3	Split Balance	Adjust the volume balance between the upper and lower sections.	9 : 9
3-4	Layer Octave	Raise the pitch of the layered sound in octave steps when using Dual mode.	0
3-5	Layer Dynamics	Adjust the dynamic sensitivity of the layered sound when using Dual mode.	10
3-6	Dual Balance	Adjust the volume balance between the main and layered sounds.	9 : 9

## ■ Entering the Key Settings menu

While the normal playing mode screen is shown in the display:

Press the  $\nabla$  or  $\wedge$  MENU buttons to select the Key Settings menu.

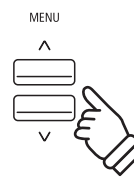
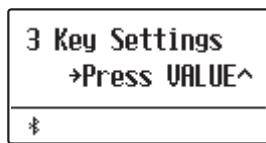

Press the VALUE  $\wedge$  button to enter the Key Settings menu.

The first page of the Key Settings menu will be shown in the display



## ■ Selecting the desired setting

After entering the Key Settings menu:

Press the  $\nabla$  or  $\wedge$  MENU buttons to cycle through the different settings pages.

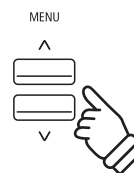
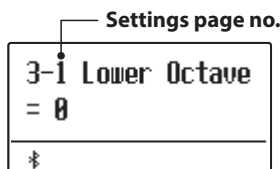

# 3-1 Lower Octave Shift

The Lower Octave Shift setting allows the pitch of the lower section when using Split mode to be raised in octave steps.

## ■ Changing the Lower Octave Shift value

After entering the Key Settings menu (page 108):

The Lower Octave Shift setting will be selected automatically.

Press the  $\nabla$  or  $\wedge$  VALUE buttons to decrease or increase the value of the Lower Octave Shift setting.

\* The pitch of the lower section can be raised by up to 3 octaves.

Press the EXIT button to exit the Lower Octave Shift setting and return to the main settings menu.

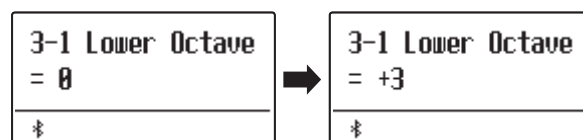

## ■ Jump to Lower Octave Shift setting shortcut

It is also possible to access the Lower Octave Shift setting directly while Split Mode or Four Hands Mode are in use.:

Press and hold the MENU  $\nabla$  or MENU  $\wedge$  buttons.

The Lower Octave Shift setting will be shown in the display.

Press the  $\nabla$  or  $\wedge$  VALUE buttons to adjust the Lower Octave Shift setting.

To exit the Lower Octave Shift setting and return to the previous screen, press the EXIT button twice.

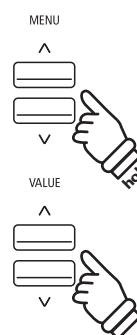

## 3-2 Lower Pedal

The Lower Pedal setting determines whether or not the sustain pedal will affect (i.e. sustain) the lower sound when using Split mode.

### ■ Lower Pedal settings

Lower Pedal	Description
Off (default)	In Split mode, lower section sounds will not be sustained when the sustain pedal is pressed.
On	In Split mode, lower section sounds will be sustained when the sustain pedal is pressed.

### ■ Changing the Lower Pedal setting

After entering the Key Settings menu (page 108):

Press the  $\nabla$  or  $\wedge$  MENU buttons to select the Lower Pedal setting.

Press the  $\nabla$  or  $\wedge$  VALUE buttons to turn the Lower Pedal setting on or off.

Press the EXIT button to exit the Lower Pedal setting and return to the main settings menu.

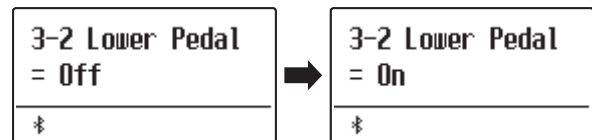

## 3-3 Split Balance

The Split Balance setting allows the volume balance between the upper and lower sections when using Split mode to be adjusted.

\* The Split Balance setting can also be used adjusted directly while Split mode is in use. Please refer to page 21 for more information.

### ■ Adjusting the Split Balance setting

After entering the Key Settings menu (page 108):

Press the  $\nabla$  or  $\wedge$  MENU buttons to select the Split Balance setting.

Press the  $\nabla$  or  $\wedge$  VALUE buttons to adjust the volume balance between the upper and lower sections.

After increasing to the maximum volume (9) of one section, the volume of the other section will start to decrease.

Press the EXIT button to exit the Split Balance setting and return to the main settings menu.

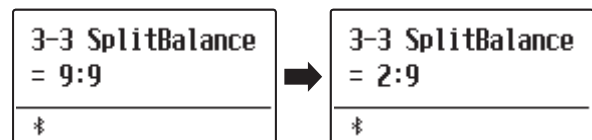

# 3-4 Layer Octave Shift

The Layer Octave Shift setting allows the pitch of the layered sound when using Dual mode to be raised or lowered in octave steps.

## ■ Changing the Layer Octave Shift value

After entering the Key Settings menu (page 108):

Press the  $\nabla$  or  $\wedge$  MENU buttons to select the Layer Octave Shift setting.

Press the  $\nabla$  or  $\wedge$  VALUE buttons to decrease or increase the value of the Layer Octave Shift setting.

\* The pitch of the layered sound can be raised or lowered by up to 2 octaves.

\* Some layered sounds may not produce a tone when the octave range is raised beyond a certain value.

Press the EXIT button to exit the Layer Octave Shift setting and return to the main settings menu.

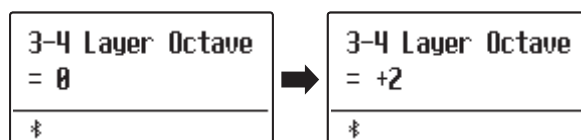

## ■ Jump to Layer Octave Shift setting shortcut

It is also possible to access the Layer Octave Shift setting directly while Dual Mode is in use.

Press and hold the MENU  $\nabla$  or MENU  $\wedge$  buttons.

The Layer Octave Shift setting will be shown in the display.

Press the  $\nabla$  or  $\wedge$  VALUE buttons to adjust the Layer Octave Shift setting.

To exit the Layer Octave Shift setting and return to the previous screen, press the EXIT button twice.

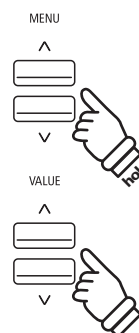

### 3-5 Layer Dynamics

When using Dual mode, sometimes simply adjusting the volume balance between the two layered sounds is not enough to create the desired sound character, especially if both sounds are very dynamic. Layering two equally dynamic sounds can prove difficult to control and play comfortably.

The Layer Dynamics Function allows the dynamic sensitivity of the layered sound to be reduced, in order to improve the blend between the two combined sounds. In addition to reducing the volume of the layered sound, limiting its dynamic sensitivity also allows the layered sound to be controlled more easily in relation to the main sound.

#### ■ Adjusting the Layer Dynamics setting

After entering the Key Settings menu (page 108):

Press the  $\nabla$  or  $\wedge$  MENU buttons to select the Layer Dynamics setting.

Press the  $\nabla$  or  $\wedge$  VALUE buttons to decrease or increase the value of the Layer Dynamics setting.

\* The layer dynamics value can be adjusted within the range of off, 1~10.

Press the EXIT button to exit the Layer Dynamics setting and return to the main settings menu.

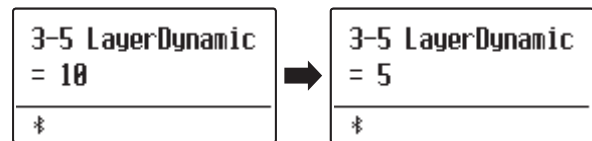

### 3-6 Dual Balance

The Dual Balance setting allows the volume balance between the main and layered sounds when using Dual mode to be adjusted.

\* The Dual Balance setting can also be used adjusted directly while Dual mode is in use. Please refer to page 19 for more information.

#### ■ Adjusting the Dual Balance setting

After entering the Key Settings menu (page 108):

Press the  $\nabla$  or  $\wedge$  MENU buttons to select the Dual Balance setting.

Press the  $\nabla$  or  $\wedge$  VALUE buttons to adjust the volume balance between the main and layered sections.

After increasing to the maximum volume (9) of one sound, the volume of the other sound will start to decrease.

Press the EXIT button to exit the Dual Balance setting and return to the main settings menu.

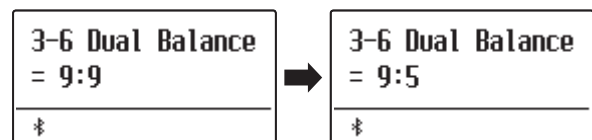

# Rhythm Section Settings

The Rhythm Section Settings menu contains settings to adjust the Rhythm Section function.

\* Any changes made by this operation will remain until the power is turned off.  
Preferred settings can be stored in a Registration memory or Startup Setting. Please refer to page 36 and 82 for more information.

## Rhythm Section settings

Page no.	Setting	Description	Default setting
4-1	Rhythm Volume	Adjust the volume of the Rhythm Section	5
4-2	Auto Fill-in	Specify how frequently an Auto Fill-in will be played.	8 bars
4-3	O.F. Ad-lib	Turn the "One Finger Ad-lib" feature on or off.	Off
4-4	ACC Mode	Specify the chord input mode used for the Rhythm Section accompaniment.	Normal
	Bass Inv.	Turn the "Bass Inv." (On-Bass chord detection) function on or off.	Off
	Preset Chord	Select the preset chord progression type.	Chord 1

\* The Bass Inv. page will only appear when ACC Mode is set to "Normal".  
\* The Preset Chord page will only appear when ACC Mode is set to "Preset Chord".

## Entering the Rhythm Settings menu

While the normal playing mode screen is shown in the display:

Press the  $\nabla$  or  $\wedge$  MENU buttons to select the Rhythm Settings menu.



Press the VALUE  $\wedge$  button to enter the Rhythm Settings menu.

The first page of the Rhythm Settings menu will be shown in the display

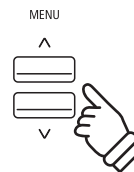

## Selecting the desired setting

After entering the Rhythm Settings menu:

Press the  $\nabla$  or  $\wedge$  MENU buttons to cycle through the different settings pages.

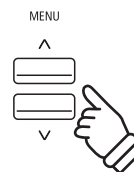
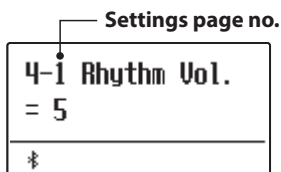

## 4-1 Rhythm Volume

The Rhythm Volume setting is used to adjust the volume level of the Rhythm Section accompaniment, relative to the main keyboard sound.

### ■ Adjust the Rhythm Volume setting

After entering the Rhythm Settings menu (page 113):

Press the  $\nabla$  or  $\wedge$  MENU buttons to select the Rhythm Volume settings page, then press the  $\nabla$  or  $\wedge$  VALUE buttons to adjust the volume level of the Rhythm Section.

\* The Rhythm Volume setting can be adjusted within the range of 1~10.

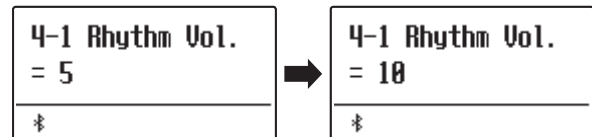

### ■ Jump to Rhythm Volume setting shortcut

It is also possible to access the Rhythm Volume setting directly while the Rhythm Section is in use.

Press and hold the MENU  $\nabla$  or MENU  $\wedge$  buttons.

The Rhythm Volume setting will be shown in the display.

Press the  $\nabla$  or  $\wedge$  VALUE buttons to adjust the Rhythm Volume setting.

To exit the Rhythm Volume setting and return to the previous screen, press the EXIT button twice.

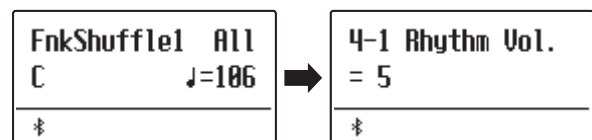

## 4-2 Auto Fill-in

The Auto Fill-in setting is used to specify how many bars of the Rhythm Section should be played before a fill-in passage is automatically added. This function can be turned off if the Auto Fill-in feature is not required.

### ■ Auto Fill-in settings

Auto Fill-in setting	Description
Off	The Rhythm Section will not play a fill-in passage automatically.
4 bars	The Rhythm Section will play an automatic fill-in passage after every 4 bars.
8 bars (default)	The Rhythm Section will play an automatic fill-in passage after every 8 bars.
12 bars	The Rhythm Section will play an automatic fill-in passage after every 12 bars.
16 bars	The Rhythm Section will play an automatic fill-in passage after every 16 bars.

### ■ Changing the Auto Fill-in setting

After entering the Rhythm Settings menu (page 113):

Press the  $\nabla$  or  $\wedge$  MENU buttons to select the Auto Fill-in settings page, then press the  $\nabla$  or  $\wedge$  VALUE buttons to change the value.

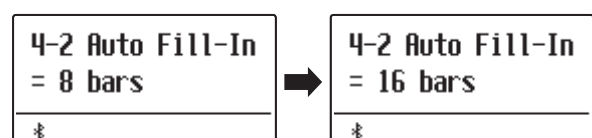

# 4-3 One Finger Ad-lib

The One Finger Ad-lib setting is used to turn the Rhythm Section's One Finger Ad-lib function on or off.

When turned on, One Finger Ad-lib allows various musical phrases to be performed at any time by pressing one of the topmost 17 keys on the keyboard. Each phrase will play for one bar, and will match the key/chord currently used by the Rhythm Section accompaniment.

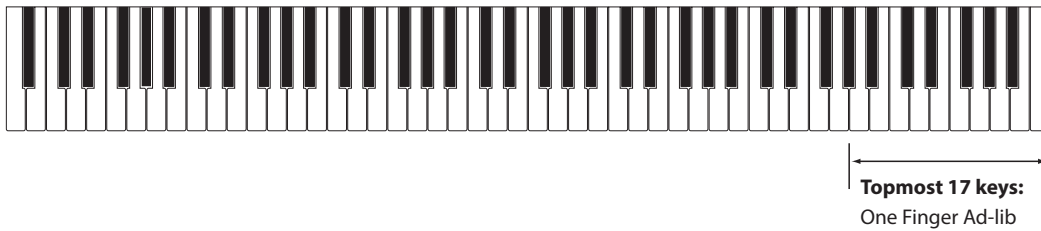

## ■ One Finger Ad-lib settings

One Finger Ad-lib setting	Description
Off (default)	A One Finger Ad-lib phrase <b>will not</b> be played.
On	A One Finger Ad-lib phrase <b>will</b> be played when pressing one of the topmost 17 keys.

## ■ Changing the One Finger Ad-lib setting

After entering the Rhythm Settings menu (page 113):

Press the  $\nabla$  or  $\wedge$  MENU buttons to select the One Finger Ad-lib settings page, then press the  $\nabla$  or  $\wedge$  VALUE buttons to turn the One Finger Ad-lib feature on or off.

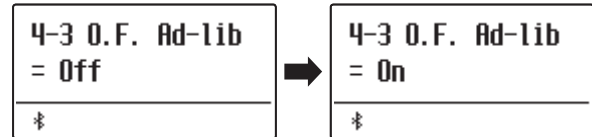

## 4-4 ACC Mode

The ACC Mode setting is used to select the Rhythm Section's chord input method.

By default, the entire keyboard can be used to play the melody, with the ES920 detecting and changing the Rhythm Section chord/key automatically. However, selecting the "1 Finger Chord" mode allows the Rhythm Section chord/key to be changed by playing single notes in the lower section, with the upper section reserved for playing the melody.

Finally, when the "Preset Chord" mode is selected, the Rhythm Section will follow the preset chord sequence specified on the Preset Chord settings page. For a complete listing of the available Rhythm Section Preset Chord sequences, please refer to page 139 of this owner's manual.

\* The default split point is set between keys F#3 and G3.

\* The Rhythm Section and Split Mode share the same split point. Please refer to page 21 for information about changing the split point.

### ■ ACC Mode settings

ACC Mode setting	Rhythm Section play/control mode
Normal (default)	Full keyboard plays melody, and controls Rhythm Section key.
1 Finger Chord	Upper section plays melody, lower section controls Rhythm Section key. Playing single notes in the lower section can change the accompaniment's chords easily.
Preset Chord	Full keyboard plays melody, Rhythm Section changes key automatically.

### ■ Normal

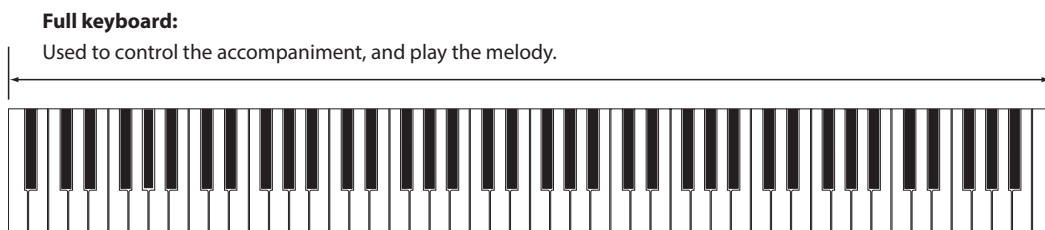

### ■ 1 Finger Chord

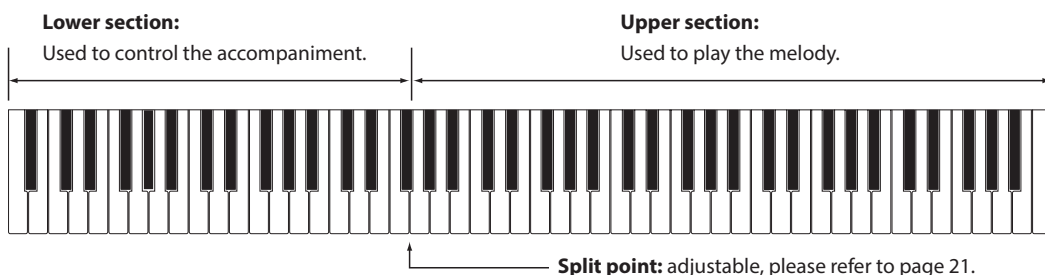

## ■ Preset Chord

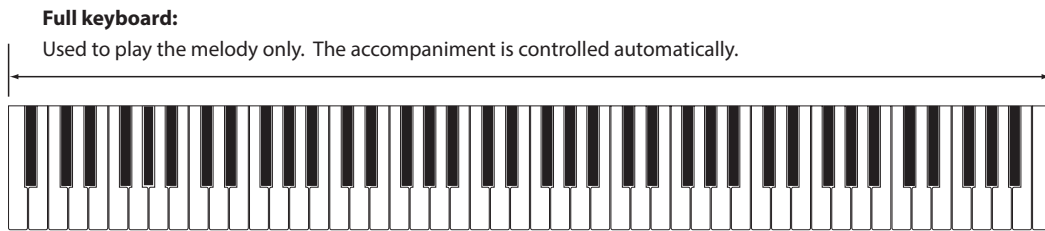

## ■ Changing the ACC Mode setting

After entering the *Rhythm Settings* menu (page 113):

Press the  $\nabla$  or  $\wedge$  MENU buttons to select the ACC Mode settings page, then press the  $\nabla$  or  $\wedge$  VALUE buttons to cycle through the different chord recognition methods.

\* The Auto Fill-in feature will be disabled when the "Preset Chord" method is selected. However, the Rhythm Section will automatically play a fill-in pattern at the end of the final bar of the specified Preset Chord sequence.

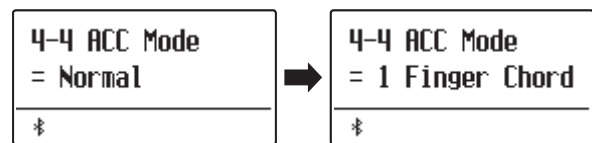

## 4-5 Bass Inversion

The Bass Inversion setting is used to play “On-Bass” chords or bass lines with the left hand.

By default, the bass part of the Rhythm Section will follow the detected chord’s root. However, when the Bass Inversion setting is set to “On”, the bass part of the Rhythm Section will follow the lowest key played on the keyboard, allowing “On-Bass” chords to be played.

An “On-Bass” chord is chord that has a different bass note to the chord’s root. This is typically indicated by the addition of slash and the letter of the bass after the root note letter. For example, a C chord over a G bass will be shown as “C/G”, while a B<sup>b</sup>7 chord over a C bass will be shown as “B<sup>b</sup>/C”.

\* This setting will only appear when the ACC Mode setting is set to “Normal”. Please refer to page 116 for more information.

### ■ Bass Inv. settings

Bass Inv. setting	Description
Off (default)	The bass part of the Rhythm Section will follow the detected chord’s root.
On	On-Bass chord recognition is enabled, and the bass part of the Rhythm Section will follow the lowest key played on the keyboard.

### ■ Off

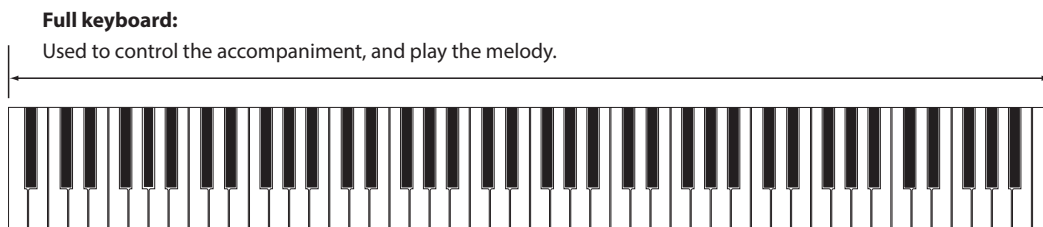

### ■ On

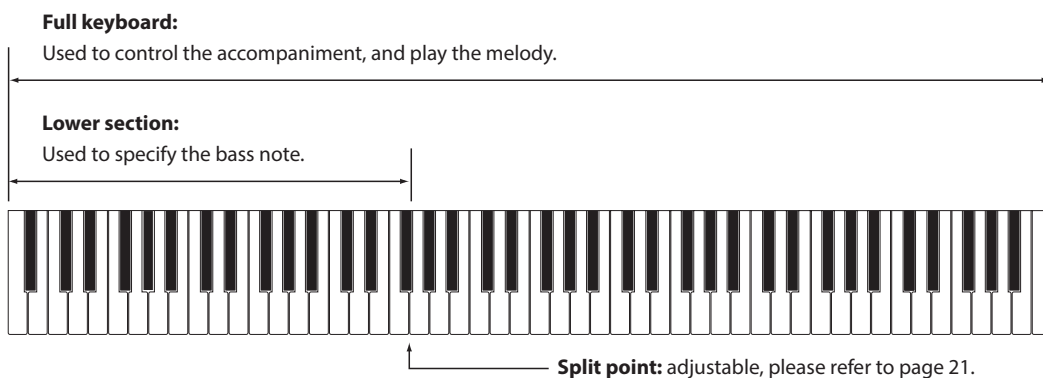

The lowest key played on the keyboard will be recognised as the bass note. However, when the lowest key is played in the upper section of the keyboard, or when three other keys are played around the lowest key, the notes will be detected as a chord, and the On-Bass note will not be specified.

## ■ Changing the Bass Inv. setting

After entering the Rhythm Settings menu (page 113):

Press the  $\nabla$  or  $\wedge$  MENU buttons to select the Bass Inv. settings page, then press the  $\nabla$  or  $\wedge$  VALUE buttons to turn the Bass Inv. setting on or off.

\* This setting will only appear when the ACC Mode setting is set to "Normal". Please refer to page 116 for more information.

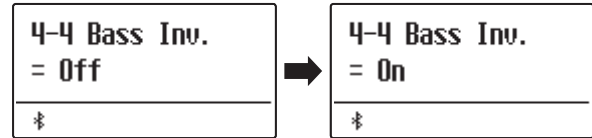

## 4-6 Preset Chord

The Preset Chord setting is used to specify which preset chord sequences the Rhythm Section will follow.

For a complete listing of the available Rhythm Section Preset Chord sequences, please refer to page 139 of this owner's manual.

\* This setting will only appear when the ACC Mode setting is set to "Preset Chord". Please refer to page 116 for more information.

## ■ Changing the Preset Chord setting

Set the Preset Chord in ACC Mode.

After entering the Rhythm Settings menu (page 113):

Press the  $\nabla$  or  $\wedge$  MENU buttons to select the Preset Chord settings page, then press the  $\nabla$  or  $\wedge$  VALUE buttons to cycle through the different Preset Chord sequences.

\* The A-B LOOP button can also be used to quickly turn the Preset Chord function on/off without entering the ACC Mode settings page.

\* When selecting a different style, the Preset Chord setting will reset to the default Preset Chord sequence for that style.

\* The preferred Preset Chord setting can be stored to a Registration memory for convenient recall. Please refer to page 36 for more information.

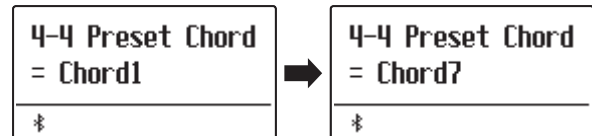

# Phones Settings

The Phones Settings menu contains settings to select the SHS (Spatial Headphone Sound) mode, the type of headphones to be used, and the output volume of the connected headphones.

\* Any changes made by this operation will remain until the power is turned off.

Preferred settings can be stored in a Registration memory or Startup Setting. Please refer to page 36 and 82 for more information.

## ■ Phones Settings

Page no.	Setting	Description	Default setting
5-1	SHS Mode	Select the desired SHS (Spatial Headphone Sound) mode.	Normal
5-2	Phones Type	Select the type of headphones to be used with the instrument.	Normal
5-3	Phones Volume	Change the maximum volume level of the headphones output.	Normal

## ■ Entering the Phones Settings menu

While the normal playing mode screen is shown in the display:

Press the  $\nabla$  or  $\wedge$  MENU buttons to select the Phones Settings menu.



Press the VALUE  $\wedge$  button to enter the Phones Settings menu.

The first page of the Phones Settings menu will be shown in the display

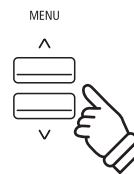

## ■ Selecting the desired setting

After entering the Phones Settings menu:

Press the  $\nabla$  or  $\wedge$  MENU buttons to cycle through the different settings pages.

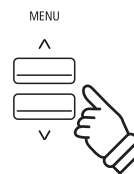
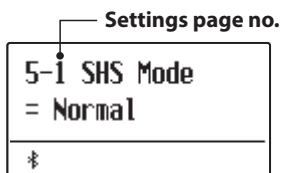

# 5-1 SHS Mode

Spatial Headphone Sound (SHS) is a special feature of the ES920 digital piano that enhances the depth and realism of the acoustic piano sound when listening through headphones or earphones.

The SHS Mode setting allows the player to select from one of three different acoustic presets that adjust the spatial positioning of the sound, while also helping to reduce auditory fatigue when using earphones or headphones for extended periods of time.

\* This setting does not affect the speaker or Line Out sound.

## ■ SHS Mode setting

SHS Mode	Description
Off	Disable the Spatial Headphone Sound feature.
Forward	Front focused, somewhat narrow spatial positioning.
Normal (default)	Naturally balanced spatial positioning that is neither forward nor wide.
Wide	Wide, very open spatial positioning.

## ■ Changing the SHS Mode setting

After entering the Phones Settings menu (page 120):

Press the  $\nabla$  or  $\wedge$  MENU buttons to select the SHS Mode setting.

Press the  $\nabla$  or  $\wedge$  VALUE buttons to cycle through the different SHS Mode types types.

Press the EXIT button to exit the SHS Mode setting and return to the main settings menu.

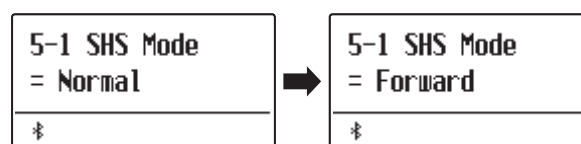

## 5-2 Phones Type

The Phones Type setting optimises the sound of the ES920 digital piano when listening through different types of headphones or earphones.

\* This setting does not affect the speaker or Line Out sound.

### ■ Phones Type setting

Phones Type	Description
Normal (default)	Disables headphone optimisation.
Open	Optimises the sound for open type headphones.
Semi-open	Optimises the sound for semi-open type headphones.
Closed	Optimises the sound for closed type headphones.
Inner-ear	Optimises the sound for inner-ear type headphones.
Canal	Optimises the sound for canal-type headphones.

### ■ Changing the Phones Type setting

After entering the Phones Settings menu (page 120):

Press the  $\vee$  or  $\wedge$  MENU buttons to select the Phones Type setting.

Press the  $\vee$  or  $\wedge$  VALUE buttons to cycle through the different earphone/headphone types.

Press the EXIT button to exit the Phones Type setting and return to the main settings menu.

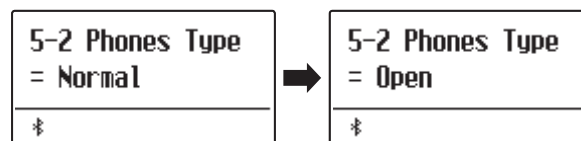

## 5-3 Phones Volume

The Phones Volume setting allows the maximum volume level of the headphones output to be increased.

The default setting for Phones Volume is “Normal” in order to protect an individual’s ears from excessive volume levels. The “High” setting may be selected when using headphones with a high impedance, or in situations where it is desirable to increase the maximum volume level of the headphones output.

\* This setting does not affect the speaker or Line Out sound.

### ■ Phones Volume setting

Phones Volume	Description
Normal (default)	The instrument’s headphone connectors will output sound at the normal volume level.
High	The instrument’s headphone connectors will output sound at an increased volume level.

### ■ Changing the Phones Volume type

After entering the Phones Settings menu (page 120):

Press the  $\vee$  or  $\wedge$  MENU buttons to select the Phones Volume setting.

Press the  $\vee$  or  $\wedge$  VALUE buttons to alternate between “Normal” and “High” Phones Volume settings.

Press the EXIT button to exit the Phones Volume setting and return to the main settings menu.

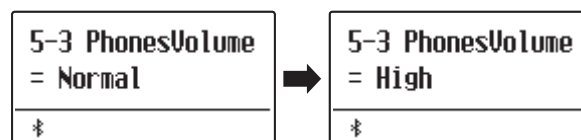

# MIDI Settings

The MIDI Settings menu contains various functions and settings related to MIDI.

\* For information regarding MIDI functions and settings, please download the supplementary PDF manual from the Kawai Global website: <https://www.kawai-global.com/support/manual>

# Bluetooth Settings

The Bluetooth Settings menu contains settings to enable/disable Bluetooth MIDI and Bluetooth Audio, and adjust the volume of the Bluetooth Audio input.

\* Availability of Bluetooth MIDI function dependent on market location.

## ■ Bluetooth Settings

Page no.	Setting	Description	Default setting
7-1	Bluetooth Audio	Enable/disable the instrument's Bluetooth Audio function.	Off
7-2	Bluetooth Audio Volume	Adjust the volume of Bluetooth Audio input.	0
7-3	Bluetooth MIDI	Enable/disable the instrument's Bluetooth MIDI function.	On

## ■ Entering the Bluetooth Settings menu

While the normal playing mode screen is shown in the display:

Press the  $\nabla$  or  $\wedge$  MENU buttons to select the Bluetooth Settings menu.



Press the VALUE  $\wedge$  button to enter the Bluetooth Settings menu.

The first page of the Bluetooth Settings menu will be shown in the display

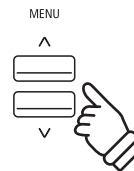

## ■ Selecting the desired setting

After entering the Bluetooth Settings menu:

Press the  $\nabla$  or  $\wedge$  MENU buttons to cycle through the different settings pages.

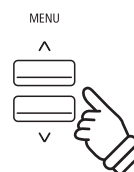
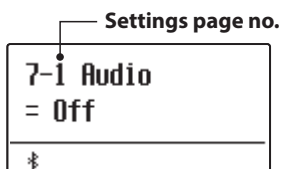

## 7-1 Bluetooth Audio

The Bluetooth Audio setting is used to enable/disable the ES920 digital piano's Bluetooth Audio function. When enabled, the ES920 digital piano can be connected to smart phones, tablets, and other smart devices to facilitate wireless audio communication, allowing music stored on a device to be played through the instrument's speaker system/headphones.

\* This setting will be stored automatically, and recalled every time the instrument is turned on.

### ■ Bluetooth Audio setting

Bluetooth Audio	Description
Off (default)	The instrument's Bluetooth Audio function will be turned off.
On	The instrument's Bluetooth Audio function will be turned on.

### ■ Changing the Bluetooth Audio setting

After entering the Bluetooth Settings menu (page 124):

Press the  $\nabla$  or  $\wedge$  MENU buttons to select the Bluetooth Audio setting.

Press the  $\nabla$  or  $\wedge$  VALUE to turn the Bluetooth Audio setting on or off.

Press the EXIT button to exit the Bluetooth Audio setting and return to the main settings menu.

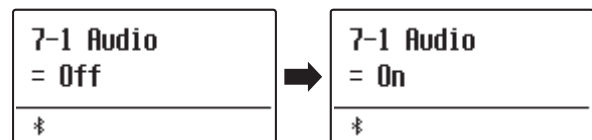

### ■ Connecting the ES920 digital piano to a smart device using Bluetooth Audio

After enabling the Bluetooth Audio function of the ES920 digital piano, enable Bluetooth communications on the smart device. After a few seconds "ES920 Audio" should appear in the smart device's Bluetooth settings device list. Tap the "ES920 Audio" entry to connect the instrument to the smart device. It should now be possible for audio produced by the smart device to be heard through the instrument's speaker system/headphones.

\* If loss of audio/connectivity or noise occurs, please check for Bluetooth Audio compatibility with the smart device manufacturer.

\* For a list of potential issues and recommended solutions when using Bluetooth communications, please refer to page 132 of this owner's manual.

\* The Auto Power Off setting will still be observed when playing audio via Bluetooth Audio.

## 7-2 Bluetooth Audio Volume

The Bluetooth Audio Volume setting is used to increase or decrease the volume level of Bluetooth Audio playback. While it's generally preferable to adjust the audio volume level on the smart device itself, this setting may still be useful in certain situations.

\* This setting will be stored automatically, and recalled every time the instrument is turned on.

### ■ Adjusting the volume setting of the Bluetooth Audio Volume

After entering the Bluetooth Settings menu (page 124):

Press the  $\nabla$  or  $\wedge$  MENU buttons to select the Bluetooth Audio Volume setting.

Press the  $\nabla$  or  $\wedge$  VALUE to increase or decrease the level of the Bluetooth Audio Volume setting.

\* The Bluetooth Audio Volume setting can be adjusted within the range of -16~+15.

\* To reset the Bluetooth Audio Volume setting to the default value, press

Press the EXIT button to exit the Bluetooth Audio Volume setting and return to the main settings menu.

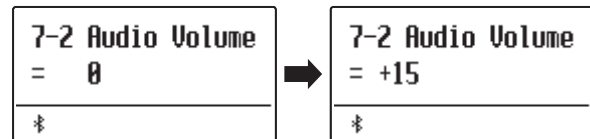

## 7-3 Bluetooth MIDI

The Bluetooth MIDI setting is used to enable/disable the ES920 digital piano's Bluetooth MIDI function. When enabled, the ES920 digital piano can be connected to smart phones, tablets, and other smart devices to facilitate wireless MIDI communication, allowing a wide range of music-related apps to be enjoyed using the instrument.

\* This setting will be stored automatically, and recalled every time the instrument is turned on.

### ■ Bluetooth MIDI setting

Bluetooth MIDI	Description
Off	The instrument's Bluetooth MIDI function will be turned off.
On (default)	The instrument's Bluetooth MIDI function will be turned on.

### ■ Changing the Bluetooth MIDI setting

After entering the Bluetooth Settings menu (page 124):

Press the  $\nabla$  or  $\wedge$  MENU buttons to select the Bluetooth MIDI setting.

Press the  $\nabla$  or  $\wedge$  VALUE to turn the Bluetooth MIDI setting on or off.

Press the EXIT button to exit the Bluetooth MIDI setting and return to the main settings menu.

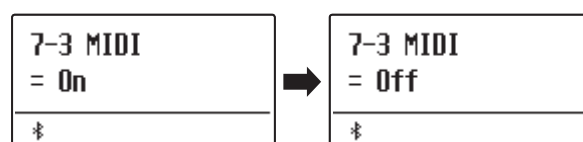

### ■ Connecting the ES920 digital piano to a smart device using Bluetooth MIDI

After enabling the Bluetooth MIDI function of the ES920 digital piano, enable Bluetooth communications on the smart device, then open the desired MIDI app. After a few seconds "ES920" should appear in the app's device list. Tap the "ES920" entry to connect the instrument to the smart device. It should now be possible for MIDI apps to communicate wirelessly with the ES920 digital piano.

- \* When the ES920 digital piano is connected to a smart device via Bluetooth MIDI, the USB MIDI and MIDI IN/OUT connectors will be disabled.
- \* Please check for Bluetooth MIDI compatibility with the smart device manufacturer and app developer.
- \* For a list of potential issues and recommended solutions when using Bluetooth communications, please refer to page 132 of this owner's manual.
- \* For more detailed instructions regarding Bluetooth pairing, please refer to the supplementary Bluetooth® Connectivity Guide manual, available from the Kawai Global website: <http://www.kawai-global.com/support/manual>

# Connecting to Other Devices

The rear side of the ES920 digital piano features a variety of jacks that allow the instrument be connected to MIDI devices, computers, speakers, and mixers. It is also possible to connect external audio sources, such as an MP3 player, tablet, or a secondary keyboard, to the ES920's amplifier and speaker system. The illustration below provides a visual overview of the instrument's connectors and typical applications.

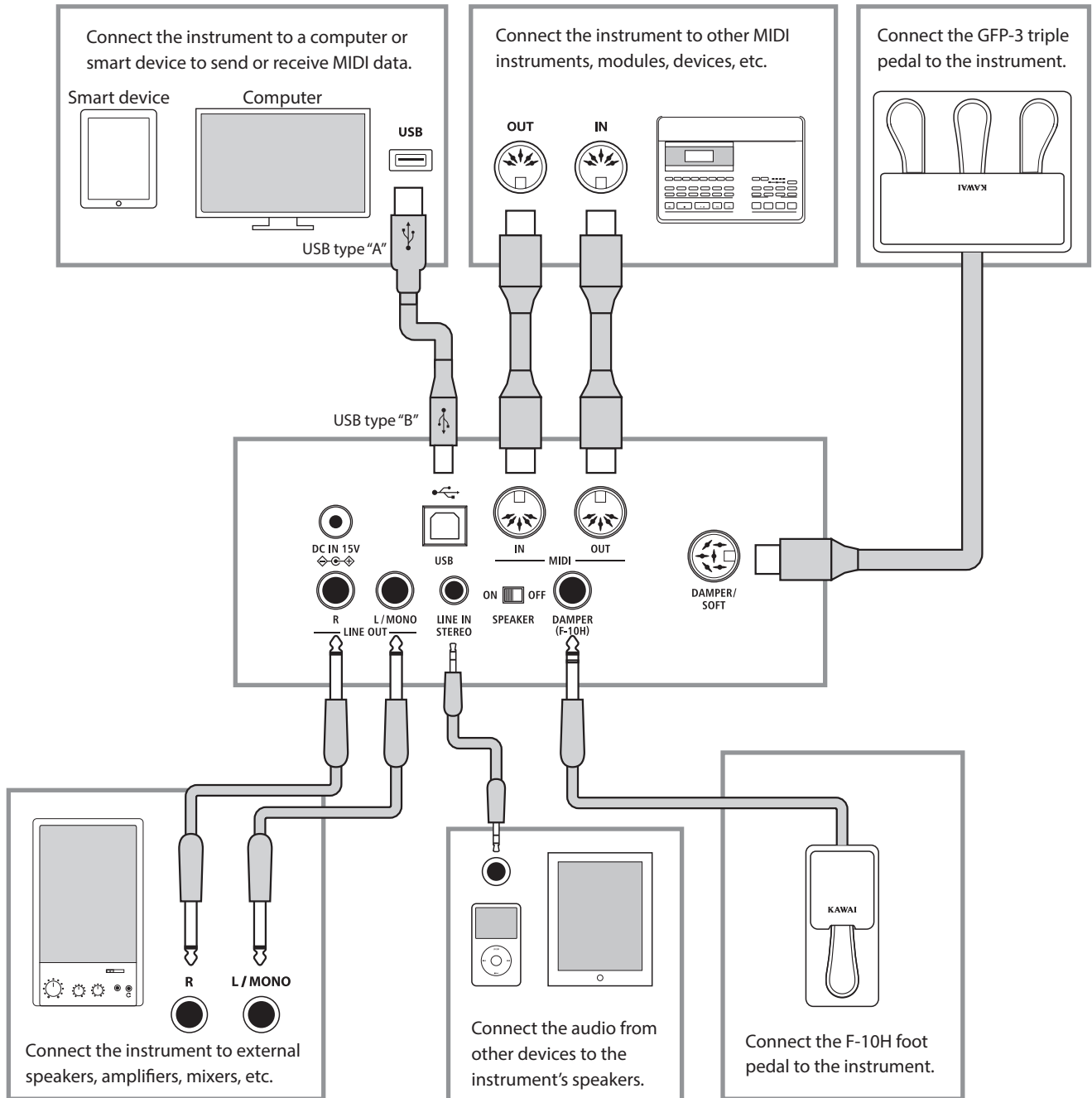

Before connecting the ES920 digital piano to other devices, ensure that the power to both the instrument and the other device is turned off. If connections are established while the power is turned on, extraneous noise that can damage the ES920 digital piano may activate the instrument's amplifier protection circuit, preventing any sound from being produced. If this occurs, turn the power off and then on again to reset the amplifier protection circuit.

Do not connect the LINE IN STEREO and LINE OUT jacks of the ES920 digital piano together with the same cable. An audio loop (oscillation sound) will occur, resulting in damage to the unit.

## Rear Connectors

---

### ■ LINE OUT jacks (1/4" phone jack)

---

These jacks are used to connect the stereo output of the instrument's sound to external speakers, amplifiers, mixers, recording devices, and similar equipment. Mono signals will be output only if a cable is connected to the L/MONO jack.

\* The Line Out Volume setting can be used to adjust the level of the LINE OUT signal. Please refer to page 78 for more information.

### ■ LINE IN STEREO jacks (1/8" mini jack)

---

This jack is used to connect the stereo output from an external audio device, such as a CD or MP3 player, to the instrument's amplifier (incl. LINE OUT) and speaker system. To adjust the LINE IN level, please use the volume controls on the device itself.

### ■ MIDI IN/OUT jacks

---

These jacks are used to connect the ES920 digital piano to external MIDI devices, and also to a computer with a MIDI interface as an alternative to the "USB to Host" port.

\* Please refer to page 124 for more information about MIDI.

### ■ SPEAKER ON/OFF switch

---

This switch is used to turn the ES920's built-in speakers on or off, and may be useful when connecting the instrument to external speakers or an amplification system via the LINE OUT jacks. Please note that when headphones are connected, sound will not be produced by the built-in speakers, regardless of the SPEAKER switch position.

### ■ DAMPER & DAMPER/SOFT jacks

---

These jacks are used to connect either the F-10H foot pedal, GFP-3 or F-302 triple pedal unit to the instrument.

\* Please refer to page 14 for more information about pedal functions.

### ■ USB to Host port ("B" type)

---

This USB port is used to connect the ES920 digital piano to a computer using an inexpensive USB cable. When connected, the instrument can be used as a standard MIDI device, allowing it to send a receive MIDI data. Connect a "B" type USB connector to the instrument, and an "A" type USB connector to the computer. With additional conversion adaptors, this port may also be used to connect the ES920 digital piano to tablets such as the Apple iPad and other mobile devices.

\* Please refer to page 130 for more information about USB MIDI.

## Upper Connectors

---

### ■ USB to Device port ("A" type)

---

This USB port is used to connect a USB memory device to the ES920 digital piano. This allows MP3/WAV audio files, and SMF song files to be played directly. It is also possible to record performances to MP3/WAV audio files, and save recorder songs stored in internal memory for posterity.

\* Only connect USB memory devices to the USB to Device port.

\* Connect the USB memory device directly, without using a USB extension cable.

### ■ USB device information

---

■ The "USB to Device" functionality of the ES920 digital piano conforms to USB2.0 Hi-Speed standards. Older USB devices can still be used, however data transfer speed will be limited to the maximum transfer speed of the device.

■ Avoid removing the USB memory device while data is being loaded or saved, files are being renamed or deleted, or the device is being formatted.

## Front Connectors

---

### ■ PHONES jacks (1/4" & 1/8" phone jacks)

---

These jacks are used to connect stereo headphones to the ES920 digital piano. Two pairs of headphones can be connected and used simultaneously. When a pair of headphones is connected, sound will not be produced by the speakers.

■ It may be necessary to format the USB memory device before it can be used with the ES920 digital piano. If so, please refer to the USB Format function instructions on page 71. Formatting the device will erase all data.

■ Other USB devices, such as computer mice, keyboards, or battery chargers etc. cannot be used with this instrument.

# USB MIDI (USB to Host Connector)

The ES920 digital piano features a “USB to Host” type connector, allowing the instrument to be connected to a computer using an inexpensive USB cable and utilised as a MIDI device. Depending on the type of computer and operating system installed, additional driver software may be required for USB MIDI communication to function correctly.

For more information regarding the USB MIDI driver, please visit the following website:

<https://www.kawai-global.com/support/downloads/>

## ■ USB MIDI information

---

- Ensure that the instrument is turned OFF before attempting to connect the USB MIDI cable.
- When connecting the instrument to a computer using the USB MIDI port, there may be a short delay before communications begin.
- If the instrument is connected to a computer via a USB hub and USB MIDI communication becomes unreliable/unstable, please connect the USB MIDI cable directly to the one of the computer’s USB ports.
- Disconnecting the USB MIDI cable suddenly, or turning the instrument on/off while using USB MIDI may cause computer instability in the following situations:
  - while installing the USB MIDI driver
  - while starting up the computer
  - while MIDI applications are performing tasks
  - while the computer is in energy saver mode
- If there are any further problems experienced with USB MIDI communication while the instrument is connected, please double-check all connections and relevant MIDI settings in the computer’s operating system.

## ■ Intellectual property rights

---

- “Windows” is a registered trademark of Microsoft Corporation.
- “Mac” is a registered trademark of Apple Computer, Inc.
- Some samples © PREMIER Engineering Inc.
- The Bluetooth® word mark and logos are registered trademarks owned by the Bluetooth SIG, Inc. and any use of such marks by Kawai Musical Instruments Mfg. Co., Ltd. is under license.
- Qualcomm aptX is a product of Qualcomm Technologies, Inc. and/or its subsidiaries. Qualcomm is a trademark of Qualcomm Incorporated, registered in the United States and other countries. aptX is a trademark of Qualcomm Technologies International, Ltd., registered in the United States and other countries.



- Other company names and product names mentioned or referenced herein are registered trademarks or trademarks of respective owners.
- Kawai Musical Instruments Mfg. Co., Ltd. shall have no liability for any acts in violation of the Copyright Act made by any users of this product.

# Information about Bluetooth®

Please refer to the following information about Bluetooth.

## ■ About Bluetooth

- The Bluetooth® word mark and logos are registered trademarks owned by the Bluetooth SIG, Inc. and any use of such marks by Kawai Musical Instruments Mfg. Co., Ltd. is under license.
- Frequency Band of Radio: 2400~2483.5 MHz Maximum Transmit Power: 2.5 mW (Bluetooth Low Energy), 4.5mW (A2DP)
- Availability of Bluetooth function dependent on market location.

## ■ For USA, Canada

It is strictly forbidden to use antenna except designated.  
This equipment must not be co-located or operated in conjunction with any other antenna or transmitter.

## ■ For Canada

- This device complies with Industry Canada's licence-exempt RSSs. Operation is subject to the following two conditions:  
(1) This device may not cause interference; and  
(2) This device must accept any interference, including interference that may cause undesired operation of the device.
- Le présent appareil est conforme aux CNR d'Industrie Canada applicables aux appareils radio exempts de licence. L'exploitation est autorisée aux deux conditions suivantes :  
(1) l'appareil ne doit pas produire de brouillage;  
(2) l'utilisateur de l'appareil doit accepter tout brouillage radioélectrique subi, même si le brouillage est susceptible d'en compromettre le fonctionnement.

## ■ For South Africa



## ■ For Argentina

Marca : KAWAI, Bluegiga  
Modelo : MBH7BLZ07, WT32i

**CNC** C-17079  
C-21199

## ■ For Korea

- 해당 무선설비는 전파혼신 가능성이 있으므로 인명안전과 관련된 서비스는 할 수 없습니다
- B 급 기기 (가정용 방송통신기자재) 이 기기는 가정용 (B 급) 전자파적합기기로서 주로 가정에서 사용하는 것을 목적으로 하며, 모든 지역에서 사용할 수 있습니다.
- 모델명 MBH7BLZ07 WT32i-A
- 인증을 받은 상표 이름제조사 Kawai Musical Instruments Manufacturing Co., Ltd. Bluegiga Technologies Oy
- 원산지 일본 핀란드
- 기자재 명칭 정소출력 무선기기 (무선데이터통신시스템용 무선기기)
- 제조년 월 제품에 붙어있는 라벨을 확인하시기 바랍니다.

## ■ For Mexico

PIANO DIGITAL  
MARCA : KAWAI  
MODELO : MBH7BLZ07, RCPKAMB16-1764  
: WT32i, RCPKAWT17-1556

La operación de este equipo está sujeta a las siguientes dos condiciones:

- (1) es posible que este equipo o dispositivo no cause interferencia perjudicial
- (2) este equipo o dispositivo debe aceptar cualquier interferencia,

## ■ For Brazil

Este equipamento opera em caráter secundário, isto é, não tem direito a proteção contra interferência prejudicial, mesmo de estações do mesmo tipo e não pode causar interferência a sistemas operando em caráter primário. Para consultas, visite: [www.anatel.gov.br](http://www.anatel.gov.br)



04349-16-10021  
02414-18-01395

## ■ For Taiwan

第十二條 經型式認證合格之低功率射頻電機，非經許可，公司、商號或使用者均不得擅自變更頻率、加大功率或變更原設計之特性及功能。  
第十四條 低功率射頻電機之使用不得影響飛航安全及干擾合法通信；經發現有干擾現象時，應立即停用，並改善至無干擾時方得繼續使用。前項合法通信，指依電信法規定作業之無線電通信。低功率射頻電機須忍受合法通信或工業、科學及醫療用電波輻射性電機設備之干擾。

# Troubleshooting

The table below summarises issues that may be experienced with the ES920 digital piano, explaining the typical cause(s), and recommended solution(s).

	Issue	Possible Cause and Solution	Page no.
Power	The instrument does not turn on.	Check that the AC power adaptor is firmly attached to the instrument, and connected to an AC outlet.	p. 15
	The instrument turns itself off after a period of inactivity.	Check that the "Auto Power Off" setting is not enabled.	p. 85
Sound	The instrument is turned on, however no sound is produced when the keys are pressed.	Check that the MASTER VOLUME slider is not set to the lowest position.	p. 15
		Check that a pair of headphones (or headphone adaptor plug) are not connected to the PHONES jacks.	p. 14
		Check that the SPEAKER ON/OFF switch (rear connectors) is not set to Off.	p. 129
		Check that the Local Control setting in the MIDI Settings menu is set to On.	p. 124
	The sound distorts when playing at very loud volume levels.	Check that the MASTER VOLUME slider is set to an appropriate level, reducing the volume if excessive distortion is heard. If connecting the instrument to an amplifier/mixer using the Line Out jacks, reduce the value of the "Line Out Volume" setting in the Basic Settings menu.	p. 15 p. 78
Strange sounds or noises are heard when playing with piano sounds.	The ES920 digital piano attempts to reproduce the rich variety of tones created by an acoustic grand piano as accurately as possible. This includes string resonances and damper noises, and other subtle characteristics that contribute to the overall piano playing experience.  While these additional tones are intended to enhance the realism of the instrument, it is possible to reduce their prominence, or disable the effects altogether using the settings in the Virtual Technician menu.	p. 86	
The top 18 notes of the keyboard sustain far longer than neighbouring notes, even when the damper pedal is not pressed.	This is the correct behaviour, and intended to reproduce the undamped notes (typically the top two octaves) of an acoustic grand piano.	–	
Phones	The headphone volume is too low.	Check the technical specifications of the headphones.  If the "Nominal Impedance" specification of the headphones is less than 100 $\Omega$ (ohms), set the "Phones Volume" setting in the "Phones Settings" menu to "High".	p. 123
USB	A USB memory device is not detected, cannot be saved to, or does not appear to function when connected to the "USB to Device" port.	Check that the USB memory device is formatted to use the FAT/FAT32 filesystem, and not set to "Write Protect" mode.  Disconnect the USB device, turn the instrument off then on, then reconnect the USB device. If the USB device still does not function, it may be damaged or incompatible. Please try using a different USB device.	p. 129
	The instrument pauses briefly when connecting a USB memory device.	This is recognised behaviour when using very large capacity USB memory devices.	p. 129
MP3/WAV/SMF Audio	No sound can be heard when playing an MP3/WAV audio file stored on a USB memory device.	Check that the audio player volume is not set to 0.  Check that the format of the audio file is supported and listed in the "Audio Player supported format specifications" table.	p. 51 p. 50
	An MP3/WAV audio file stored on a USB memory device sounds strange, or does not play back correctly.	Check that the format of the audio file is supported and listed in the "Audio Player supported format specifications" table.  The file transfer speed of the USB memory device may be too slow to play the audio file. Please try using a different USB memory device, ensuring that it conforms to USB2.0 Hi-Speed standards.	p. 50
	An SMF MIDI file stored on a USB memory device sounds strange when played back.	The ES920 digital piano does not contain the full General MIDI sound bank selection. Consequently, some SMF song files may not be reproduced entirely accurately when played through the instrument.	p. 54
	When recording MP3/WAV audio files, the volume is too low/too high (distorted).	Adjust the "Audio Recorder Gain" setting in the "Basic Settings" menu.	p. 78

# Demo Song List

Sound Name	Song Title	Composer
<b>PIANO1</b>		
SK ConcertGrand	Polonaise Brillante Op.22	Chopin
EX ConcertGrand	Polonaise-Fantaisie	Chopin
Jazz Clean	Original	Kawai
Warm Grand	Sonata No.30 Op.109	Beethoven
Pop Grand	Original	Kawai
<b>PIANO2</b>		
SK-5 GrandPiano	Lieder Ohne Worte No.18 "Duetto"	Mendelssohn
Upright Piano	Alpengluehen Op.193	Oesten
Pop Grand 2	-	-
Modern Piano	Original	Kawai
Rock Piano	Original	Kawai
<b>E.PIANO</b>		
Classic E.Piano (*)	Original	Kawai
Classic E.P. 2	-	-
Classic E.P. 3	-	-
60's E.Piano	-	-
60's E.Piano 2	-	-
Modern E.Piano	Original	Kawai
<b>ORGAN</b>		
Jazz Organ (*)	Original	Kawai
Drawbar Organ (*)	Original	Kawai
Ballad Organ	-	-
Principal Oct.	-	-
Church Organ	Chorale Prelude "Wachet auf, ruft uns die Stimme"	J. S. Bach
<b>HARPSI/MALLETS</b>		
Harpsichord (*)	French Suite No. 6	J. S. Bach
Vibraphone	Original	Kawai
Clavi	Original	Kawai
Marimba	-	-
<b>STRINGS/CHOIR</b>		
String Ensemble	Le quattro stagioni: La primavera	A. Vivaldi
Slow Strings	Original	Kawai
String Pad	Original	Kawai
Warm Strings	-	-
Choir Ooh/Aah	Original	Kawai
Pop Ensemble	-	-
Square Pad	-	-
New Age Pad	Original	Kawai
<b>BASS</b>		
Electric Bass	Original	Kawai
Electric Bass 2 (*)	-	-
Electric Bass 3 (*)	-	-
Wood Bass	Original	Kawai
W. Bass & Ride	Original	Kawai

(\*) PREMIER Sound  
 Copyright©PREMIER Engineering Inc.2018  
 PREMIER SOUND FACTORY

\*\* Kawai regret that sheet music for Kawai original demo songs is not available.

# Rhythm Section Style List

Genre	Style Name
16th Swing	Funk Shuffle 1
	Funk Shuffle 2
	Hip Hop 1
	Hip Hop 2
	Hip Hop 3
	Hip Hop 4
	16 Shuffle 1
	16 Shuffle 2
	16 Shuffle 3
16th Funk	Funky Beat 1
	Funky Beat 2
	Funky Beat 3
	Funk 1
	Funk 2
	Funk 3
16th Straight	Jazz Funk
	16 Beat 1
	16 Beat 2
	16 Beat 3
	16 Beat 4
	Rim Beat
	Roll Beat
	Light Ride 1
Dixie Rock	
16th Latin	Surdo Samba
	Latin Groove
	Light Samba
	Songo
	Samba
	Merenge
16th Dance/Techno	Funky Beat 4
	16 Beat 5
	Disco 1
	Disco 2
	Techno 1
	Techno 2
	Techno 3
	Heavy Techno
16th Ballad	Ballad 1
	Ballad 2
	Ballad 3
	Ballad 4
	Ballad 5
	Light Ride 2
	Electro Pop 1
	Electro Pop 2
	16 Shuffle 4
	8th Ballad
Slow Rock	
R&B Ballad	
Triplet 50's Ballad	
Triplet R&B Ballad	

Genre	Style Name
8th Straight	8 Beat 1
	8 Beat 2
	Smooth Beat
	Pop 1
	Pop 2
	Ride Beat
	Slip Beat
8th Rock	Jazz Rock
	8 Beat 3
	Rock Beat 1
	Rock Beat 2
	Rock Beat 3
	Rock Beat 4
	Blues/Rock
	Heavy Beat
	Hard Rock
	Surf Rock
R&B	
8th Swing	Motown 1
	8th Fast Shuffle
	Motown 2
	Gospel Shuffle
	Ragtime
	Country 2 Beat
Triplet/Waltz	Triplet Rock 1
	Triplet Rock 2
	Bembe
	Rock Shuffle
	Boogie
	Triplet 1
	Triplet 2
	Reggae
Gospel Ballad	
Waltz	
Jazz	H.H. Swing
	Ride Swing
	Fast 4 Beat
	Afro Cuban
	Jazz Waltz 1
	Jazz Waltz 2
	5/4 Swing
Latin	H.H. Bossa Nova
	Ride Bossa Nova
	Beguine
	Mambo
	Cha Cha
	Tango
	Habanera

# Rhythm Section Chord Types

The tables below list chord types recognised by the ES920 digital piano's Rhythm Section. Each chord can be played by pressing the notes marked with a ● symbol in the diagrams below. When the ACC Mode setting is set to "1 Finger Chord", the common Major, Minor, M7, and 7, chord types can also be played by pressing just the notes marked with a ★ symbol.

Chord Name	Notes	Chord Name	Notes	Chord Name	Notes
C Maj		D <sup>b</sup> Maj (C#)		D Maj	
C sus4		D <sup>b</sup> sus4 (C#)		D sus4	
C aug		D <sup>b</sup> aug (C#)		D aug	
C min		D <sup>b</sup> min (C#)		D min	
C M7		D <sup>b</sup> M7 (C#)		D M7	
C 6		D <sup>b</sup> 6 (C#)		D 6	
C m7		D <sup>b</sup> m7 (C#)		D m7	
C mM7		D <sup>b</sup> mM7 (C#)		D mM7	
C m6		D <sup>b</sup> m6 (C#)		D m6	
C 7		D <sup>b</sup> 7 (C#)		D 7	
C 7 <sup>(b5)</sup>		D <sup>b</sup> 7 <sup>(b5)</sup> (C#)		D 7 <sup>(b5)</sup>	
C 7 <sup>(#5)</sup>		D <sup>b</sup> 7 <sup>(#5)</sup> (C#)		D 7 <sup>(#5)</sup>	
C 7sus4		D <sup>b</sup> 7sus4 (C#)		D 7sus4	
C m7 <sup>(b5)</sup>		D <sup>b</sup> m7 <sup>(b5)</sup> (C#)		D m7 <sup>(b5)</sup>	
C dim		D <sup>b</sup> dim (C#)		D dim	

# Rhythm Section Chord Types

Chord Name	Notes	Chord Name	Notes	Chord Name	Notes
E <sup>b</sup> Maj (D <sup>#</sup> )		E Maj		F Maj	
E <sup>b</sup> sus4 (D <sup>#</sup> )		E sus4		F sus4	
E <sup>b</sup> aug (D <sup>#</sup> )		E aug		F aug	
E <sup>b</sup> min (D <sup>#</sup> )		E min		F min	
E <sup>b</sup> M7 (D <sup>#</sup> )		E M7		F M7	
E <sup>b</sup> 6 (D <sup>#</sup> )		E 6		F 6	
E <sup>b</sup> m7 (D <sup>#</sup> )		E m7		F m7	
E <sup>b</sup> mM7 (D <sup>#</sup> )		E mM7		F mM7	
E <sup>b</sup> m6 (D <sup>#</sup> )		E m6		F m6	
E <sup>b</sup> 7 (D <sup>#</sup> )		E 7		F 7	
E <sup>b</sup> 7 <sup>(b5)</sup> (D <sup>#</sup> )		E 7 <sup>(b5)</sup>		F 7 <sup>(b5)</sup>	
E <sup>b</sup> 7 <sup>(#5)</sup> (D <sup>#</sup> )		E 7 <sup>(#5)</sup>		F 7 <sup>(#5)</sup>	
E <sup>b</sup> 7sus4 (D <sup>#</sup> )		E 7sus4		F 7sus4	
E <sup>b</sup> m7 <sup>(b5)</sup> (D <sup>#</sup> )		E m7 <sup>(b5)</sup>		F m7 <sup>(b5)</sup>	
E <sup>b</sup> dim (D <sup>#</sup> )		E dim		F dim	

Chord Name	Notes	Chord Name	Notes	Chord Name	Notes
G <sup>b</sup> Maj (F <sup>#</sup> )		G Maj		A <sup>b</sup> Maj (G <sup>#</sup> )	
G <sup>b</sup> sus4 (F <sup>#</sup> )		G sus4		A <sup>b</sup> sus4 (G <sup>#</sup> )	
G <sup>b</sup> aug (F <sup>#</sup> )		G aug		A <sup>b</sup> aug (G <sup>#</sup> )	
G <sup>b</sup> min (F <sup>#</sup> )		G min		A <sup>b</sup> min (G <sup>#</sup> )	
G <sup>b</sup> M7 (F <sup>#</sup> )		G M7		A <sup>b</sup> M7 (G <sup>#</sup> )	
G <sup>b</sup> 6 (F <sup>#</sup> )		G 6		A <sup>b</sup> 6 (G <sup>#</sup> )	
G <sup>b</sup> m7 (F <sup>#</sup> )		G m7		A <sup>b</sup> m7 (G <sup>#</sup> )	
G <sup>b</sup> mM7 (F <sup>#</sup> )		G mM7		A <sup>b</sup> mM7 (G <sup>#</sup> )	
G <sup>b</sup> m6 (F <sup>#</sup> )		G m6		A <sup>b</sup> m6 (G <sup>#</sup> )	
G <sup>b</sup> 7 (F <sup>#</sup> )		G 7		A <sup>b</sup> 7 (G <sup>#</sup> )	
G <sup>b</sup> 7 <sup>(b5)</sup> (F <sup>#</sup> )		G 7 <sup>(b5)</sup>		A <sup>b</sup> 7 <sup>(b5)</sup> (G <sup>#</sup> )	
G <sup>b</sup> 7 <sup>(#5)</sup> (F <sup>#</sup> )		G 7 <sup>(#5)</sup>		A <sup>b</sup> 7 <sup>(#5)</sup> (G <sup>#</sup> )	
G <sup>b</sup> 7sus4 (F <sup>#</sup> )		G 7sus4		A <sup>b</sup> 7sus4 (G <sup>#</sup> )	
G <sup>b</sup> m7 <sup>(b5)</sup> (F <sup>#</sup> )		G m7 <sup>(b5)</sup>		A <sup>b</sup> m7 <sup>(b5)</sup> (G <sup>#</sup> )	
G <sup>b</sup> dim (F <sup>#</sup> )		G dim		A <sup>b</sup> dim (G <sup>#</sup> )	

# Rhythm Section Chord Types

Chord Name	Notes	Chord Name	Notes	Chord Name	Notes
A Maj		B <sup>b</sup> Maj (A <sup>#</sup> )		B Maj	
A sus4		B <sup>b</sup> sus4 (A <sup>#</sup> )		B sus4	
A aug		B <sup>b</sup> aug (A <sup>#</sup> )		B aug	
A min		B <sup>b</sup> min (A <sup>#</sup> )		B min	
A M7		B <sup>b</sup> M7 (A <sup>#</sup> )		B M7	
A 6		B <sup>b</sup> 6 (A <sup>#</sup> )		B 6	
A m7		B <sup>b</sup> m7 (A <sup>#</sup> )		B m7	
A mM7		B <sup>b</sup> mM7 (A <sup>#</sup> )		B mM7	
A m6		B <sup>b</sup> m6 (A <sup>#</sup> )		B m6	
A 7		B <sup>b</sup> 7 (A <sup>#</sup> )		B 7	
A 7 <sup>(b5)</sup>		B <sup>b</sup> 7 <sup>(b5)</sup> (A <sup>#</sup> )		B 7 <sup>(b5)</sup>	
A 7 <sup>(#5)</sup>		B <sup>b</sup> 7 <sup>(#5)</sup> (A <sup>#</sup> )		B 7 <sup>(#5)</sup>	
A 7sus4		B <sup>b</sup> 7sus4 (A <sup>#</sup> )		B 7sus4	
A m7 <sup>(b5)</sup>		B <sup>b</sup> m7 <sup>(b5)</sup> (A <sup>#</sup> )		B m7 <sup>(b5)</sup>	
A dim		B <sup>b</sup> dim (A <sup>#</sup> )		B dim	

# Rhythm Section Preset Chord Sequences

The table below lists Preset Chord sequences utilised by the ES920 digital piano's Rhythm Section when the "ACC Mode" setting is set to "Preset Chord".

The Preset Chord sequences can last for 8, 12, or 16 bars, with the bar number and chord name written in the spaces below. If a chord name is not written, the previous chord will continued to be played. The more complicated chord names, such as "F#m7(b5)", may appear in a simplified form when shown in the display. If two chords are listed (e.g. "D/C"), the first letter indicates the key of the chord, while the second letter indicates the key of the bass part.

Preset Chord	No. of bars	Chord pattern															
		1 (9)		2 (10)		3 (11)		4 (12)		5 (13)		6 (14)		7 (15)		8 (16)	
Chord1	8	CM7		Bm7(b5)	Bb7	Am7		Gm7	C7	Fm7		Em7	A7	Dm7		G7sus4	G7
Chord2	12	F#m7(b5)		B7		Em7		A7		F#m7(b5)		B7		Em7		A7	
Chord3	8	C								F							
Chord4	8	C7						F7		Bb7		G7		C7			
Chord5	8	C7				Ab7		Bb7		C7				Ab7		G7	
Chord6	16	Cm7		D7(#5)		G7sus4		G7sus4		Cm7						G7(#5)	
		EbM7						G7		Cm7		F7		BbM7		G7(#5)	
Chord7	12	CM7	Am7	Dm7	G7sus4	CM7	Am7	Dm7	G7sus4	CM7	Am7	Dm7	G7sus4	CM7	Am7	Dm7	G7sus4
		Em7	Am7	Em7	Am7	Dm7		G7sus4									
Chord8	8	CM7		Dm7		CM7		Dm7	G7	Gm7	C7	Fm7		Fm7	Bb7	CM7	
Chord9	8	C7				Bb7				C7				G7		F7	
Chord10	16	C7				Eb7				F7				C7			
		C7				Eb7				F7				G7			
Chord11	8	C7				F7		C7		C7				F7		G7	
Chord12	8	Cm7				F7				Cm7				F7			
Chord13	8	AbM7		DbM7		Gm7		C7		AbM7		Gm7		F#dim		G7(#5)	
Chord14	8	Ab7		G7(#5)		Cm7		F7		Ab7		G7(#5)		F7			
Chord15	8	C7								Eb7		F7		C7			
Chord16	16	AbM7				Gm7				AbM7				Gm7		C7sus4	C7
		AbM7				Gm7				AbM7				G7sus4		G7	
Chord17	8	C		CM7		C7		FM7		FmM7		CM7		F#m7(b5)		G7sus4	G7
Chord18	8	Cm7				Dm7		Gaug		Cm7				Dm7		Gaug	
Chord19	16	AbM7		Bb7		EbM7		A7		AbM7		Gaug		Cm7		F7	
		AbM7		Bb7		Gm7		C7		AbM7		G7(#5)		F7			
Chord20	8	C				D/C				Bb/C				F/C			
Chord21	8	C		G		Bb		F		Ab		Eb		Dm7		G7	
Chord22	8	CM7		B7(#5)	B7	Bb6		A7		AbM7		Dm7	G7	CM7	Am7	Dm7	G7
Chord23	8	Ab/Bb		CM7		Ab/Bb		EbM7		Bm7		Bb7		F/A	Dm7(b5)/Ab	G7	G7(#5)
Chord24	8	C7						G7								C7	
Chord25	8	F7				C7				F7				G7			
Chord26	8	CM7		G7(#5)		Gm7	C7	FM7		Fm7	Bb7	CM7		Am7	D7	G7	
Chord27	8	C7sus4								Bb7sus4							
Chord28	16	CM7				C7				CM7				C7			
		F#m7(b5)		B7		Em7		A7		F#m7(b5)		B7		Em7			
Chord29	8	Cm	CmM7	Cm7	Am7(b5)	AbM7		G7(#5)		Cm	CmM7	Cm7	Am7(b5)	AbM7		G7(#5)	
Chord30	16	Fm7		Bb7		EbM7		AbM7		Dm7(b5)		G7(#5)		Gm7(b5)		C7	
		Fm7		Bb7		EbM7		AbM7		Dm7(b5)		G7(#5)		Cm7			
Chord31	8	C		Dm		G	F	C		A7		Dm		G	F	C	
Chord32	8	C		G7		Am		Am7/G		F		D7		G7			
Chord33	8	C		G7		F				D7		G7		Am			
Chord34	16	C7				F7				C7				F7			
		G7		F7		G7		F7		C7							
Chord35	8	C		AbM7		Bb		Gm7		C		AbM7		Bb		Gm7	
Chord36	8	AbM7				EbM7				AbM7				EbM7		D7	DbM7
Chord37	16	C		Em7		Fm7		C				Em7		Fm7		C	
		Am7		Em7		Am7		G7		Am7		Em7		G7sus4		G7	
Chord38	8	Em7				Dm7				Em7				Dm7			
Chord39	8	C7								Bb7sus4							
Chord40	8	C7				BbM7		Bb7		C7				BbM7		Db7	
Chord41	8	C7		Bb/C		Ab/Bb		Bb		C7		Bb/C		Ab/Bb		Bb	
Chord42	8	C7				Cm7		Gm7/C		F/C		Ab/C		Gsus4/C			
Chord43	8	C7				Eb7		D7		F7		E7		A7			
Chord44	12	FM7				Bm7(b5)				Em7				EbM7			
		Dm7		G7		C6											
Chord45	8	C		Am		F		C	G	C		Am		F		G7	
Chord46	8	Em7		Am7		Dm7		G7		Em7		A7		Dm7		G7	
Chord47	8	FM7		Em7		FM7		Am7		Fm7	Bb7	EbM7	AbM7	Dm7		G7sus4	
Chord48	8	FM7		Em7		FM7		Em7	C7sus4	FM7		Em7		FM7	E7	Dm7	G7sus4

# Rhythm Section Preset Chord Sequences

Preset Chord	No. of bars	Chord pattern																
		1 (9)	2 (10)	3 (11)	4 (12)	5 (13)	6 (14)	7 (15)	8 (16)									
Chord49	8	CM7		FM7		CM7		FM7		Bm7	E7	AM7		GM7		FM7	G7sus4	
Chord50	8	A-M7		Gm7		B-M7		A-M7	A-7	D-M7		Cm7		Dm7(b-5)		G7		
Chord51	8	C		G/B		Gm/B-		F/A		A-6		C/G		F#m7(b-5)		G7		
Chord52	8	F		F#dim		C/G		E7/G#		Am7		D7		Dm7		G7sus4	G7	
Chord53	8	CM7		B-M7		CM7		B-M7		Am7		D7		Dm7		G7	G7(#5)	
Chord54	8	F#m7(b-5)		F7		Em7		A7	A7(#5)	Dm7		G7	G7(#5)	CM7		Gm7	C7	
Chord55	8	FM7		FmM7		Em7	E7	Am7		Dm7		G7sus4		CM7				
Chord56	8	CM7		FM7		Bm7(b-5)	E7	Am7	C7	FM7		Em7	Am7	Dm7		G7sus4	G7	
Chord57	8	C	G/B	F/A	C/G	F	C/E	D7/F#	G7	C	G/B	F/A	C/G	D7/F#	D7	G7sus4	G7	
Chord58	8	CM7		FM7		Dm7		G7sus4	G7	FM7		G7	Em7	Am7	Dm7		G7sus4	G7
Chord59	8	FM7		CM7		FM7		CM7		Em7(b-5)	A7	Dm7		Fm7		G7sus4	G7	
Chord60	8	C		F		C		F		Am	Dm	G						
Chord61	8	C		F		C		F		G	Am	F	G	C				
Chord62	8	C	Am	Dm	G	C	Am	Dm	G	Em	Am	Dm	G7	Em	Am	Dm	G7	
Chord63	8	Cm7	Gm7	Cm7	Gm7	Cm7	Gm7	Cm7	Gm7	Fm7				G7	A-7	G7		
Chord64	8	C		CM7		C7		F		Dm7		Am7		D7		G7		
Chord65	16	CM7		F7		CM7		C7		CM7		F7						
Chord66	8	Fm7	B-7	CM7	C7	Fm7	F#dim	G7(#5)										
Chord67	16	C		Am		Dm		G		Dm		G7		Em	Am	Dm	G7	
Chord68	16	Am7	D7	G7sus4	C	Am7	G7sus4	C	Am7	Dm7	G7	C						
Chord69	8	Fm7	E7	Am7	C	Am7	G7sus4	C	Am7	Dm7	G7	C						
Chord70	8	C7																
Chord71	8	C7																
Chord72	8	C7																
Chord73	12	C		F		C		F		C		G		F				
Chord74	8	C		F		C		F										
Chord75	16	Cm																
Chord76	8	C																
Chord77	8	C																
Chord78	16	C																
Chord79	8	C																
Chord80	16	C																
Chord81	16	C																
Chord82	8	C																
Chord83	8	C																
Chord84	8	C																
Chord85	8	C																
Chord86	12	C																
Chord87	8	C	G	Em7	Am7	Dm7	D7	G7		C	G	Em7	A7	Dm7	G7	C		
Chord88	16	C																
Chord89	16	C																
Chord90	8	C																
Chord91	16	C																
Chord92	12	C																
Chord93	16	C																
Chord94	16	C																
Chord95	16	C																
Chord96	8	C																
Chord97	8	C																
Chord98	16	C																
Chord99	16	C																
Chord100	16	C																

# EU Declaration of Conformity

<b>BG</b>	<b>ОПРОСТЕНА ЕС ДЕКЛАРАЦИЯ ЗА СЪОТВЕТСТВИЕ</b>
Bulgarian	C настoшaтo Kawai Европа GmbH декларира, че този тип радиосъоръжение [ ES920 ] е в съответствие с Директива 2014/53/ЕС. Цялостният текст на ЕС декларацията за съответствие може да се намери на следния интернет адрес:
<b>ES</b>	<b>DECLARACIÓN UE DE CONFORMIDAD SIMPLIFICADA</b>
Spanish	Por la presente, Kawai Europa GmbH declara que el tipo de equipo radioeléctrico [ ES920 ] es conforme con la Directiva 2014/53/UE. El texto completo de la declaración UE de conformidad está disponible en la dirección Internet siguiente:
<b>CS</b>	<b>ZJEDNODUŠENÉ EU PROHLÁŠENÍ O SHODĚ</b>
Czech	Tímto Kawai Europa GmbH prohlašuje, že typ rádiového zařízení [ ES920 ] je v souladu se směrnicí 2014/53/EU. Úplné znění EU prohlášení o shodě je k dispozici na této internetové adrese:
<b>DA</b>	<b>FORENKLET EU-OVERENSSTEMMELSESERKLÆRING</b>
Danish	Hermed erklærer Kawai Europa GmbH, at radioudstyrstypen [ ES920 ] er i overensstemmelse med direktiv 2014/53/EU. EU-overensstemmelseserklæringens fulde tekst kan findes på følgende internetadresse:
<b>DE</b>	<b>VEREINFACHTE EU-KONFORMITÄTSERKLÄRUNG</b>
German	Hiermit erklärt Kawai Europa GmbH, dass der Funkanlagentyp [ ES920 ] der Richtlinie 2014/53/EU entspricht. Der vollständige Text der EU-Konformitätserklärung ist unter der folgenden Internetadresse verfügbar:
<b>ET</b>	<b>LIHTSUSTATUD ELI VASTAVUSDEKLARATSIOON</b>
Estonian	Käesolevaga deklareerib Kawai Europa GmbH, et käesolev raadioseadme tüüp [ ES920 ] vastab direktiivi 2014/53/EL nõuetele. ELi vastavusdeklaratsiooni täielik tekst on kättesaadav järgmisel internetiaadressil:
<b>EL</b>	<b>ΑΠΛΟΥΣΤΕΥΜΕΝΗ ΔΗΛΩΣΗ ΣΥΜΜΟΡΦΩΣΗΣ ΕΕ</b>
Greek	Με την παρούσα ο/η Kawai Europa GmbH, δηλώνει ότι ο ραδιοεξοπλισμός [ ES920 ] πληροί την οδηγία 2014/53/ΕΕ. Το πλήρες κείμενο της δήλωσης συμμόρφωσης ΕΕ διατίθεται στην ακόλουθη ιστοσελίδα στο διαδίκτυο:
<b>EN</b>	<b>SIMPLIFIED EU DECLARATION OF CONFORMITY</b>
English	Hereby, Kawai Europa GmbH declares that the radio equipment type [ ES920 ] is in compliance with Directive 2014/53/EU. The full text of the EU declaration of conformity is available at the following internet address:
<b>FR</b>	<b>DECLARATION UE DE CONFORMITE SIMPLIFIEE</b>
French	Le soussigné, Kawai Europa GmbH, déclare que l'équipement radioélectrique du type [ ES920 ] est conforme à la directive 2014/53/UE. Le texte complet de la déclaration UE de conformité est disponible à l'adresse internet suivante:
<b>HR</b>	<b>POJEDNOSTAVLJENA EU IZJAVA O SUKLADNOSTI</b>
Croatian	Kawai Europa GmbH ovime izjavljuje da je radijska oprema tipa [ ES920 ] u skladu s Direktivom 2014/53/EU. Cjeloviti tekst EU izjave o sukladnosti dostupan je na sljedećoj internetskoj adresi:
<b>IT</b>	<b>DICHIARAZIONE DI CONFORMITÀ UE SEMPLIFICATA</b>
Italian	Il fabbricante, Kawai Europa GmbH, dichiara che il tipo di apparecchiatura radio [ ES920 ] è conforme alla direttiva 2014/53/UE. Il testo completo della dichiarazione di conformità UE è disponibile al seguente indirizzo Internet:
<b>LV</b>	<b>VIENKĀRŠOTA ES ATBILSTĪBAS DEKLARĀCIJA</b>
Latvian	Ar šo Kawai Europa GmbH deklarē, ka radioiekārta [ ES920 ] atbilst Direktīvai 2014/53/ES. Pilns ES atbilstības deklarācijas teksts ir pieejams šādā interneta vietnē:
<b>LT</b>	<b>SUPAPRASTINTA ES ATITIKTIES DEKLARACIJA</b>
Lithuanian	Aš, Kawai Europa GmbH, patvirtinu, kad radijo įrenginių tipas [ ES920 ] atitinka Direktyvą 2014/53/ES. Visas ES atitikties deklaracijos tekstas prieinamas šiuo interneto adresu:
<b>HU</b>	<b>EGYSZERŰSÍTETT EU-MEGFELELŐSÉGI NYILATKOZAT</b>
Hungarian	Kawai Europa GmbH igazolja, hogy a [ ES920 ] típusú rádióberendezés megfelel a 2014/53/EU irányelvnek. Az EU-megfelelőségi nyilatkozat teljes szövege elérhető a következő internetes címen:
<b>MT</b>	<b>DIKJARAZZJONI SEMPLIFIKATA TA' KONFORMITÀ TAL-UE</b>
Maltese	B'dan, Kawai Europa GmbH, niddikjara li dan it-tip ta' tagħmir tar-radju [ ES920 ] huwa konformi mad-Direttiva 2014/53/UE. It-test kollu tad-dikjarazzjoni ta' konformità tal-UE huwa disponibbli f'dan l-indirizz tal-Internet li ġej:
<b>NL</b>	<b>VEREENVOUDIGDE EU-CONFORMITEITSVERKLARING</b>
Dutch	Hierbij verklaar ik, Kawai Europa GmbH, dat het type radioapparatuur [ ES920 ] conform is met Richtlijn 2014/53/EU. De volledige tekst van de EU-conformiteitsverklaring kan worden geraadpleegd op het volgende internetadres:
<b>PL</b>	<b>UPROSZCZONA DEKLARACJA ZGODNOŚCI UE</b>
Polish	Kawai Europa GmbH niniejszym oświadcza, że typ urządzenia radiowego [ ES920 ] jest zgodny z dyrektywą 2014/53/UE. Pełny tekst deklaracji zgodności UE jest dostępny pod następującym adresem internetowym:
<b>PT</b>	<b>DECLARAÇÃO UE DE CONFORMIDADE SIMPLIFICADA</b>
Portuguese	O(a) abaixo assinado(a) Kawai Europa GmbH declara que o presente tipo de equipamento de rádio [ ES920 ] está em conformidade com a Diretiva 2014/53/UE. O texto integral da declaração de conformidade está disponível no seguinte endereço de Internet:
<b>RO</b>	<b>DECLARAȚIA UE DE CONFORMITATE SIMPLIFICATĂ</b>
Romanian	Prin prezenta, Kawai Europa GmbH declară că tipul de echipamente radio [ ES920 ] este în conformitate cu Directiva 2014/53/UE. Textul integral al declarației UE de conformitate este disponibil la următoarea adresă internet:
<b>SK</b>	<b>ZJEDNODUŠENÉ EÚ VYHLÁSENIE O ZHODE</b>
Slovak	Kawai Europa GmbH týmto vyhlasuje, že rádiové zariadenie typu [ ES920 ] je v súlade so smernicou 2014/53/EÚ. Úplné EÚ vyhlásenie o zhode je k dispozícii na tejto internetovej adrese:
<b>SL</b>	<b>POENOSTAVLJENA IZJAVA EU O SKLADNOSTI</b>
Slovenian	Kawai Europa GmbH potrjuje, da je tip radijske opreme [ ES920 ] skladen z Direktivo 2014/53/EU. Celotno besedilo izjave EU o skladnosti je na voljo na naslednjem spletnem naslovu:
<b>FI</b>	<b>YKSINKERTAISTETTU EU-VAATIMUSTENMUKAISUUSVAKUUTUS</b>
Finnish	Kawai Europa GmbH vakuuttaa, että radiolaitetyyppi [ ES920 ] on direktiivin 2014/53/EU mukainen. EU-vaatimustenmukaisuusvakuutuksen täysimittainen teksti on saatavilla seuraavassa internetosoitteessa:
<b>SV</b>	<b>FÖRENKLAD EU-FÖRSÄKRAN OM ÖVERENSSTÄMMELSE</b>
Swedish	Härmed försäkrar Kawai Europa GmbH att denna typ av radioutrustning [ ES920 ] överensstämmer med direktiv 2014/53/EU. Den fullständiga texten till EU-försäkran om överensstämmelse finns på följande webbadress:
<a href="https://www.kawai-global.com/">https://www.kawai-global.com/</a>	

# Kawai ES920 Specifications

Keyboard	Responsive Hammer III (RHIII) action with Let-Off 88 weighted keys with Ivory Touch key surfaces	
Sound Source	Harmonic Imaging XL™ (HI-XL), 88-key piano sampling	
Internal Sounds	38 voices	PIANO: 10 sounds, E.PIANO: 6 sounds, ORGAN: 5 sounds HARPSI/MALLETS: 4 sounds, STRINGS/CHOIR: 8 sounds, BASS: 5 sounds, MIDI only (Rhythm Section): 38 sounds + 4 drum kits
Polyphony	max. 256 notes	
Keyboard Modes	Dual Mode, Split Mode, Four Hands Mode (Volume/Balance adjustable)	
Reverb	Type:	Room, Lounge, Small Hall, Concert Hall, Live Hall, Cathedral
	Parameters:	Reverb Depth, Reverb Time
Effects	Type:	Mono Delay, Ping Delay, Triple Delay, Chorus, Classic Chorus, Ensemble, Tremolo, Classic Tremolo, Vibrato Tremolo, Auto Pan, Classic Auto Pan, Phaser, Classic Phaser, Compressor, Rotary 1, Rotary2
	Parameters:	Dry/Wet, Time, Speed, Feedback, HighDamp, Depth. Parameters dependent on effect type.
Amp Simulator	Type:	S.Case I, S.Case II, L.Cabinet
	Parameters:	Drive, Level, EQ Low, EQ High
Virtual Technician	Touch Curve, Voicing, Damper Resonance, Damper Noise, String Resonance, Undamped String Resonance, Cabinet Resonance, Key-off Effect, Fall-back Noise, Hammer Noise, Hammer Delay, Topboard, Decay Time, Release Time, Minimum Touch, Stretch Tuning/Stretch Curve/User Tuning, Temperament, Temperament Key, User Key Volume, Half-Pedal Adjust, Soft Pedal Depth	
Internal Recorder	10 song, 2 track recorder – approximately 90,000 note memory capacity	
USB Functions	Playback:	MP3, WAV, SMF
	Record:	MP3, WAV
	Other:	Overdubbing, Convert Song to Audio, Load Internal Song, Save Internal Song, Save SMF Song, Load Registration, Save Registration, Load Startup Setting, Save Startup Setting, Rename File, Delete File, Format USB
Metronome	1/4, 2/4, 3/4, 4/4, 5/4, 3/8, 6/8, 7/8, 9/8, 12/8 (Volume/Tempo adjustable)	
Rhythm Section	Styles:	100 rhythms (x 2 variations), 4-part accompaniment, 100 preset chord sequences
	Settings:	Rhythm Volume, Auto Fill-in, One Finger Ad-lib, ACC Mode, Preset Chord, Rhythm Parts Select
Demo Songs	Main demo song, Rhythm Section demo song, 25 sound demo songs	
Registrations	28 memories (7 x 4)	
Other Functions	Key/Song Transpose, Tone Control (incl. Brilliance, UserEQ), Wall EQ, Speaker Volume, Low Volume Balance, Phones Volume, Line Out Volume, Audio Recorder Gain, Tuning, Damper Hold, GFP-3 Mode, Four Hands, Startup Setting, Factory Reset, Auto Power Off, Lower Octave Shift, Lower Pedal On/Off, Split Balance, Layer Octave Shift, Layer Dynamics, Dual Balance, SHS Mode, Phones Type, MIDI Channel, Send PGM#, Local Control, Transmit PGM#, Multi-timbral Mode, Channel Mute, Auto Power Off, Speakers On/Off	
Display	128 x 64 pixel OLED	
Pedal	F-10H damper pedal (with half-pedal support)	
Bluetooth*	Bluetooth (Ver. 4.1; GATT compatible) Bluetooth Low Energy MIDI Specification compliant, Bluetooth Audio	
Connectors	LINE IN (1/8" STEREO), LINE OUT (1/4" L/MONO, R [unbalanced]), Headphones x 2 (1/4", 1/8"), MIDI (IN/OUT), USB to Host, USB to Device, DAMPER (for F-10H), DAMPER/SOFT/SOSTENUTO (for GFP-3), PEDAL (for F-302)	
Speaker System	Speakers:	(8 x 12 cm) x 2
	Output Power:	20 W x 2
Power Consumption	18 W (PS-154 AC adaptor)	
Dimensions	1340 (W) x 372 (D) x 144 (H) mm / 52 3/4" (W) x 14 2/3" (D) x 5 2/3" (H)	
Weight	17.0 kg / 37.5 lbs.	

Specifications are subject to change without notice.

\* Availability of Bluetooth function dependent on market location.

# Owner's Manual Conventions

This owner's manual utilises a number of illustrative conventions in order to explain the ES920's various functions. The examples below provide an overview of the button LED indicator states and press types, and the appearance of different kinds of text.

## ■ Button LED indicator states



**LED indicator off:**  
Sound/Function is not selected.



**LED indicator on:**  
Sound/Function is selected.

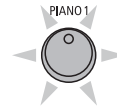

**LED indicator flashing:**  
Sound/Function is selected in a temporary state.

## ■ Button press types



**Normal press:**  
Select a sound or function.



**Press twice:**  
Select a sound or function.



**Press multiple times:**  
Cycle through sounds or settings.

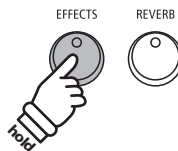

**Press and hold:**  
Select a function's settings.

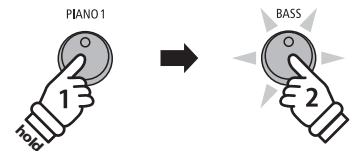

**Press and hold, then press X:**  
Combine two sounds, or store registration memories etc.

## ■ Text appearance

Normal instruction and explanation text is written in regular type at 9 pt. size.

\* Notes about functions are marked with an asterisk and written in 8 pt. size.

*Reminders about previous operations are written in italic type at 9 pt. size.*

• **Captions explaining the display or button functions, are written in bold type at 8.5 pt. size.**

*Example operations are written in italic type at 8 pt. size, and enclosed within a grey box.*









# **KAWAI**

---

THE FUTURE OF THE PIANO

