

Reference Manual

GAIA 2



The content of this manual applies to version 1.10 of this instrument's system program or later.
Download the latest program from the Roland website to update the GAIA-2.

https://roland.cm/gaia-2_dl

- We recommend using Adobe Acrobat Reader when viewing this content from your computer. The links used to jump between pages may not work correctly when you view the content in your browser.
- Use the keyboard shortcuts on your computer to go back to the previous screen.
 - Windows In Acrobat Reader, press [Alt] + [+].
 - Mac In Acrobat Reader, press [Command] + [<].
 - In Preview, press [Command] + [[]] (left bracket).

Navi map

Click (tap) an icon to jump to the related page.

 Panel map

 Panel map (+SHIFT)

Tone Select

Tone Write

Tone Init

Tone Edit

Edit map

 OSC
Common

Edit map

 Mixer
LFO

Edit map

 Filter
Amp

Edit map

 Control
Effects

 Motional Pad

 Chord Memory

 Arpeggio

 Sequencer

 System

 File

 Utility

Parameter list

 Master
Effects

Backup
Restore

Format

MFX list

 Connect
ext device

Export
Import

Factory
Reset

Wavetable list

 Model Expansion
SH-101

Panel map

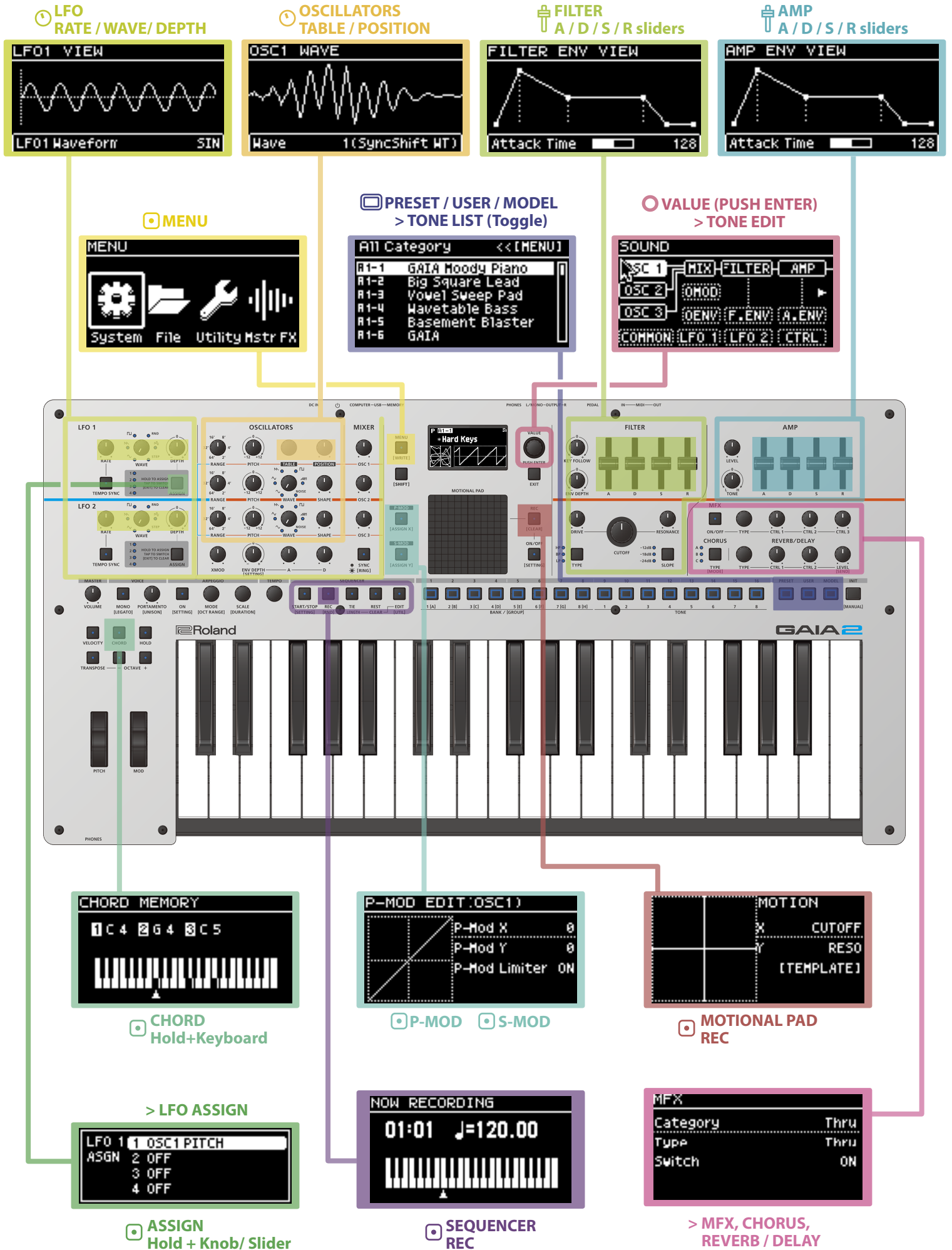

Panel map - SHIFT functions -

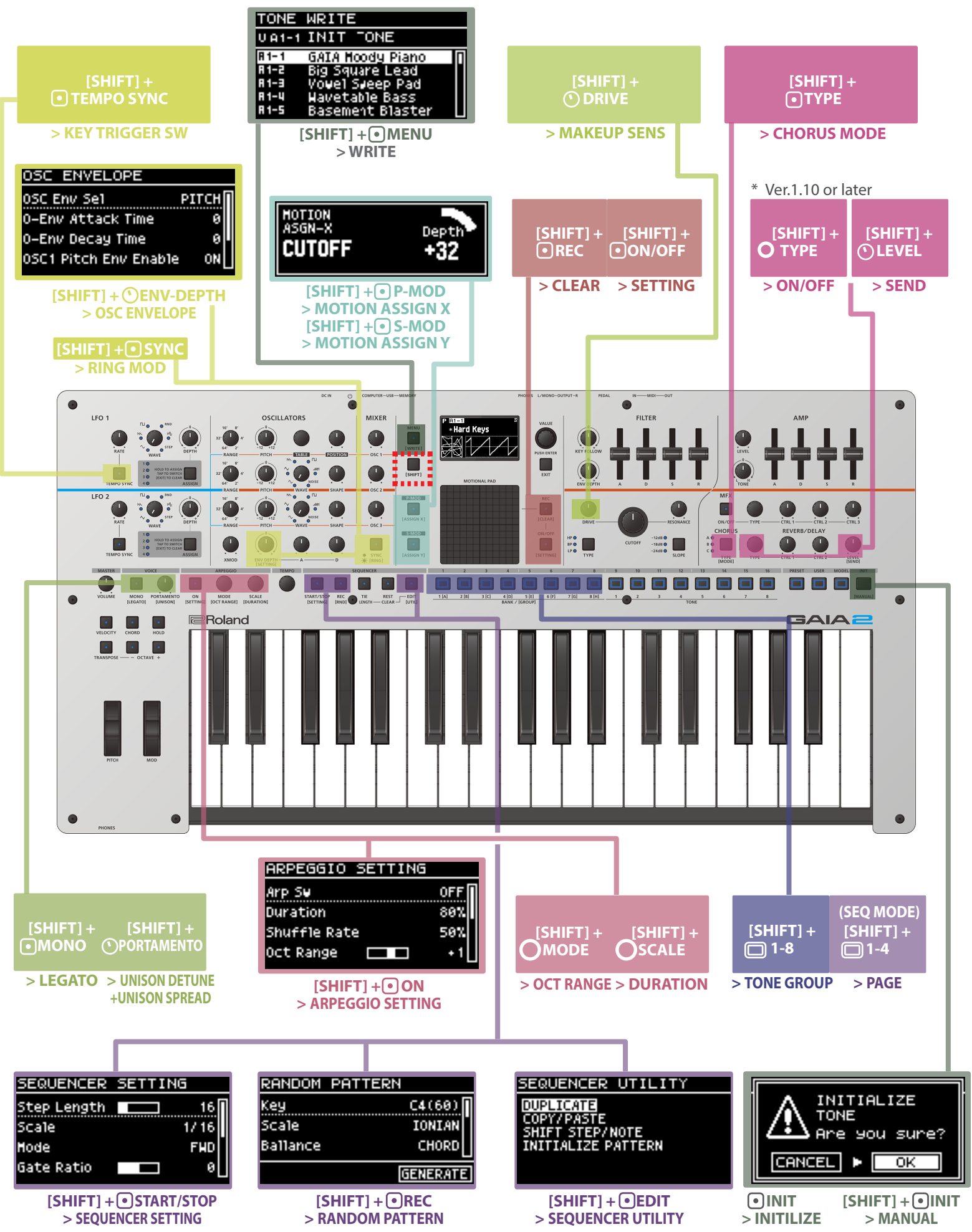

[SHIFT] + [TEMPO SYNC]
> KEY TRIGGER SW

OSC ENVELOPE
OSC Env Sel PITCH
0-Env Attack Time 0
0-Env Decay Time 0
OSC1 Pitch Env Enable ON

[SHIFT] + [ENV-DEPTH]
> OSC ENVELOPE

[SHIFT] + [SYNC]
> RING MOD

TONE WRITE
VA1-1 INIT TONE
R1-1 GAIA Moody Piano
R1-2 Big Square Lead
R1-3 Vowel Sweep Pad
R1-4 Wavetable Bass
R1-5 Basement Blaster

[SHIFT] + [MENU]
> WRITE

MOTION
ASGN-X Depth +32
CUTOFF

[SHIFT] + [P-MOD]
> MOTION ASSIGN X
[SHIFT] + [S-MOD]
> MOTION ASSIGN Y

[SHIFT] + [DRIVE]
> MAKEUP SENS

[SHIFT] + [REC] > CLEAR
[SHIFT] + [ON/OFF] > SETTING

[SHIFT] + [TYPE]
> CHORUS MODE

* Ver.1.10 or later

[SHIFT] + [TYPE] > ON/OFF
[SHIFT] + [LEVEL] > SEND

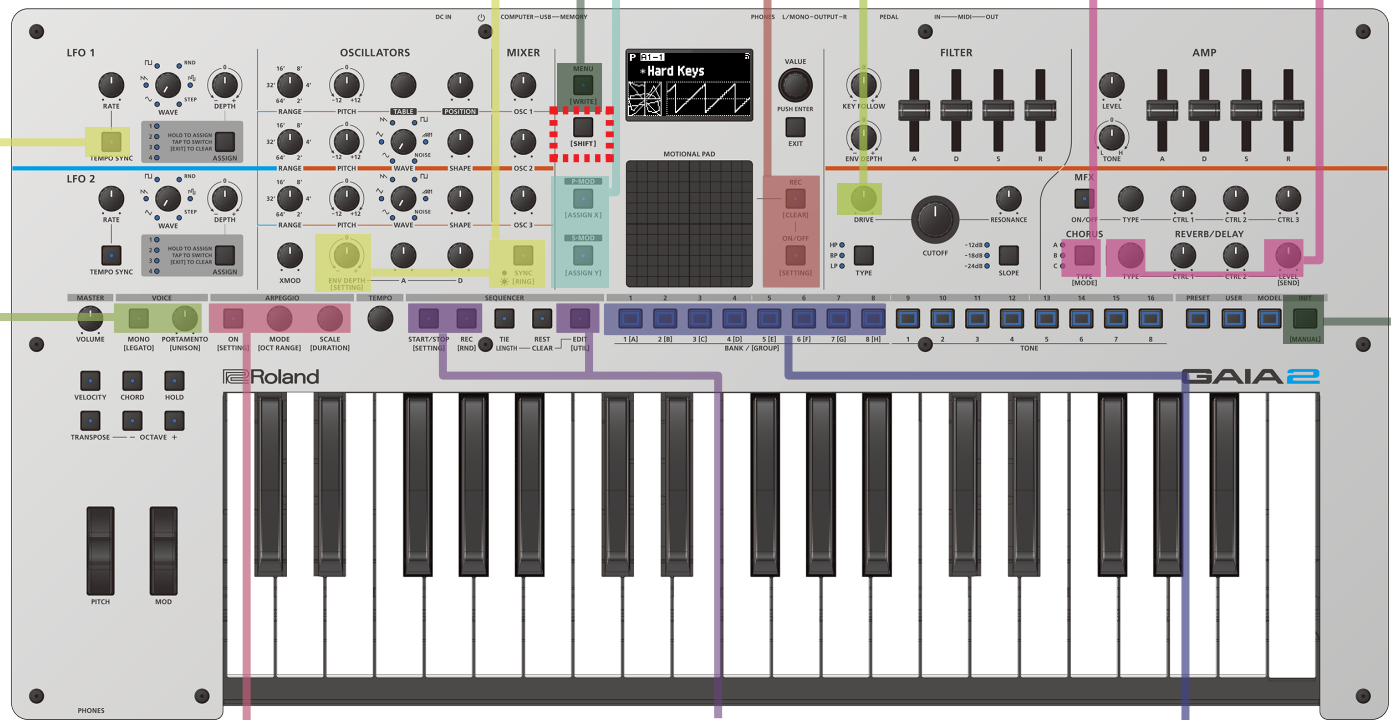

[SHIFT] + [MONO] > LEGATO
[SHIFT] + [PORTAMENTO] > UNISON DETUNE + UNISON SPREAD

ARPEGGIO SETTING
Arp Sv OFF
Duration 80%
Shuffle Rate 50%
Oct Range +1

[SHIFT] + [ON]
> ARPEGGIO SETTING

[SHIFT] + [MODE] > OCT RANGE
[SHIFT] + [SCALE] > DURATION

[SHIFT] + [1-8] > TONE GROUP
[SHIFT] + [1-4] > PAGE

SEQUENCER SETTING
Step Length 16
Scale 1/16
Mode FWD
Gate Ratio 0

[SHIFT] + [START/STOP]
> SEQUENCER SETTING

RANDOM PATTERN
Key C4(60)
Scale IONIAN
Ballance CHORD
[GENERATE]

[SHIFT] + [REC]
> RANDOM PATTERN

SEQUENCER UTILITY
DUPLICATE
COPY/PASTE
SHIFT STEP/NOTE
INITIALIZE PATTERN

[SHIFT] + [EDIT]
> SEQUENCER UTILITY

INITIALIZE TONE
Are you sure?
[CANCEL] [OK]

[INIT] > INITIALIZE
[SHIFT] + [INIT] > MANUAL

1. Connect the included AC adaptor to the DC IN jack.
2. Connect your mixer, amp or speakers to the OUTPUT jacks.
3. Connect a pair of headphones to the PHONES jack.
 - * If your headphones have a stereo mini plug, connect the headphones to the front PHONES jack.
4. Turn on the [POWER] switch of this instrument first, and then turn on any equipment that's connected to this instrument.
5. Adjust the volume of the connected devices.
6. Adjust the volume of this instrument with the [VOLUME] knob.
7. Play the keyboard to make sound.

* Before turning the unit on/off, always be sure to turn the volume down. Even with the volume turned down, you might hear some sound when switching the unit on/off. However, this is normal and does not indicate a malfunction.

* The power to this unit will be turned off automatically after a predetermined amount of time has passed since it was last used for playing music, or its buttons or controls were operated.

If you do not want the power to be turned off automatically, disengage the Auto Off function. → "Auto Off function"

* Unsaved data is lost when the power turns off. You must save any data in advance that you want to keep.

* To restore power, turn the power on again.

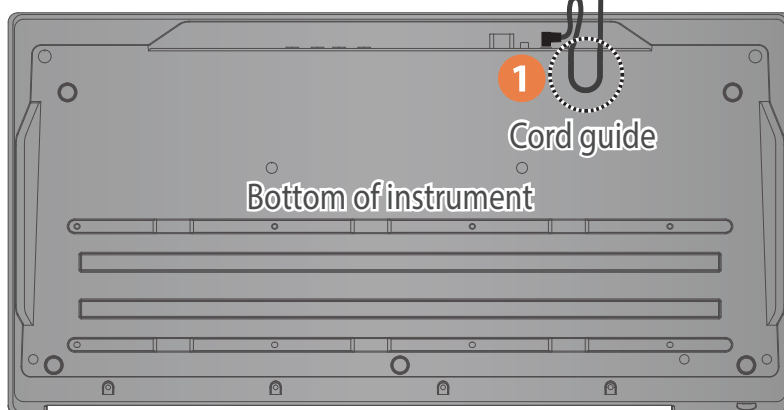
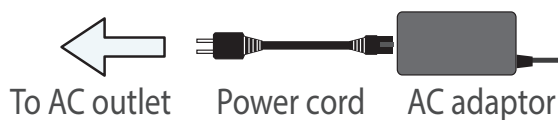

* Use the cord guide on the bottom of the instrument to secure the AC adaptor cord, as shown in the illustration.

OUTPUT jacks (L/MONO, R)

These are jacks for outputting the audio signal.

* Use the L/MONO jack for mono output.

PHONES jack

Connect your headphones here.

* When using headphones with a stereo mini plug, connect the headphones to the front jack.

[POWER] switch

Turns the power on/off.

DC IN jack

Connect the included AC adaptor here.

MASTER

[VOLUME] knob

Adjusts the overall volume.

The following icons are used in the illustrations of this manual to describe the operating steps.

Icon	Explanation
VALUE	Turn the [VALUE] (ENTER) knob.
ENTER	Press the [VALUE] (ENTER) knob. * You may need to double-click in some cases.
Button name	Press the button that's shown.
SHIFT + Button name	Hold down the [SHIFT] button and press the button shown. + [SHIFT] * You may need to hold down another button besides [SHIFT] in some cases. * You may also need to hold down two buttons for a separate operation in some cases.

Icon	Explanation						
Knob	Operate the knob or slider. 						
PAD	Operate the motional pad. <table border="1"> <thead> <tr> <th>Swipe</th> <th>Tap</th> <th>Double-tap</th> </tr> </thead> <tbody> <tr> <td>Place your finger on the pad and slide it in the desired direction. </td> <td>Lightly touch the pad with your finger. </td> <td>Tap the pad twice. </td> </tr> </tbody> </table>	Swipe	Tap	Double-tap	Place your finger on the pad and slide it in the desired direction. 	Lightly touch the pad with your finger. 	Tap the pad twice.
Swipe	Tap	Double-tap					
Place your finger on the pad and slide it in the desired direction. 	Lightly touch the pad with your finger. 	Tap the pad twice. 					
Keyboard	Play the keyboard. 						

Jumping between pages



Touch (click) the Navi icon at the top right-hand corner of the pages to jump to the Navi map.

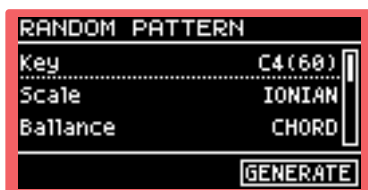

Screens with a border



Screens without a border

When you touch (click) on screens that are outlined with a border, this jumps to the related operation page or parameter list.

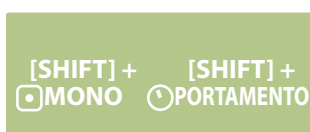

When you touch (click) on other icons shaped like these, this jumps to the related operation page or parameter list.

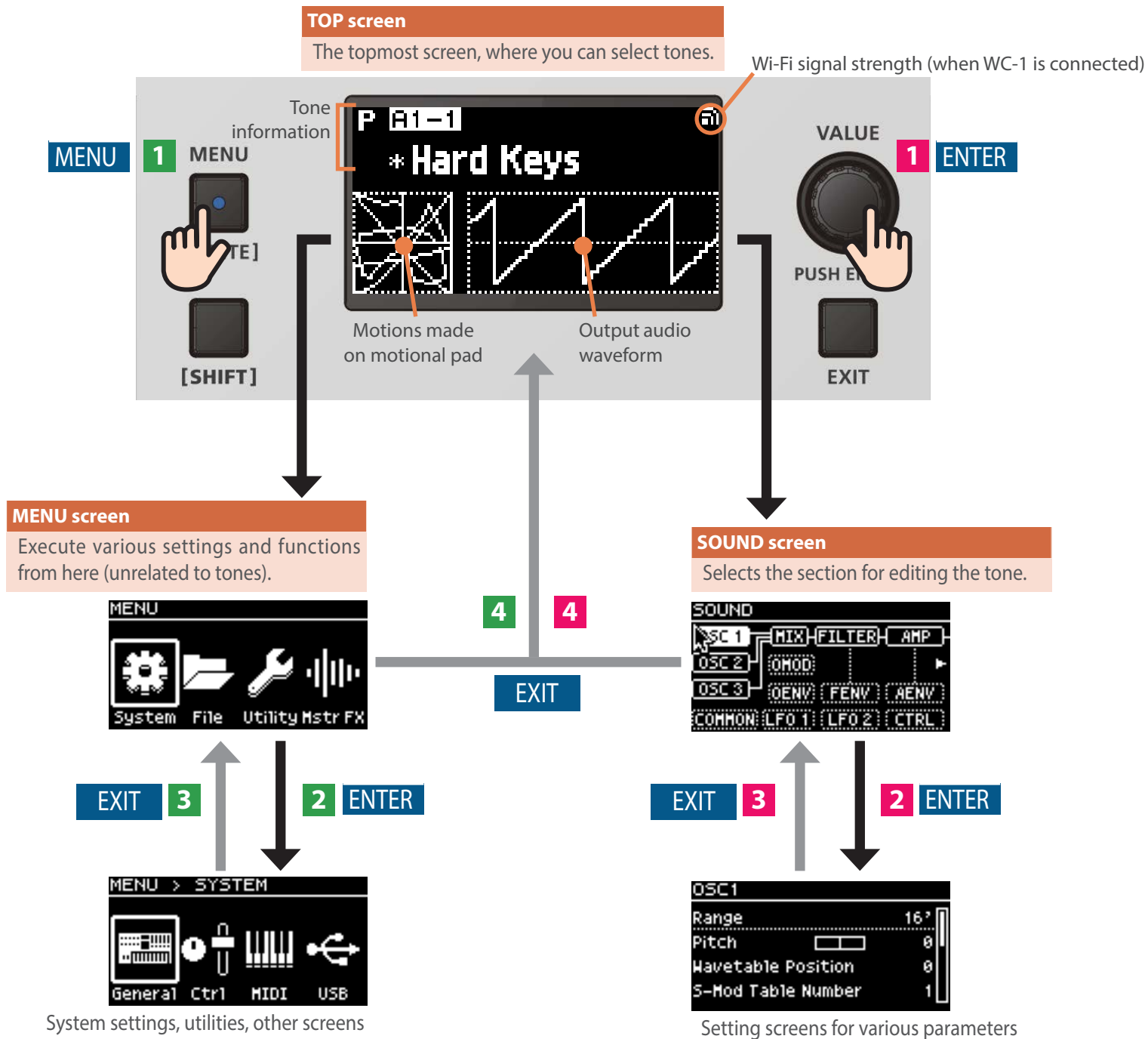

Display

Shows various information for the operations.

[MENU] button

Shows the MENU screen.

[SHIFT] button

Use this button with other buttons to switch the function of the buttons and knobs.

* The functions you can access with the [SHIFT] button are shown below (or to the side of) each button or knob. (Some functions are not shown).

[VALUE] (ENTER) knob

Turn: moves the cursor and sets the parameters.

Press: confirms the parameters and executes operations.

When you press this on the TOP screen, this shows the SOUND screen.

[EXIT] button

Returns to the previous or initial screen.

For some screens, this cancels the operation currently being executed.

On nearly all of the screens, you only need to operate (turn/press) the [VALUE] (ENTER) knobs to select parameters and edit values.

This manual explains how to use the [VALUE] (ENTER) knob to operate this instrument.

- When a parameter is selected, double-click the [VALUE] knob, or press [VALUE] (ENTER) knob while holding down the [SHIFT] button to show the value list.
- Press the [EXIT] button to return to the previous screen or to cancel editing a value.
- Press the [EXIT] button a number of times to return to the TOP screen.

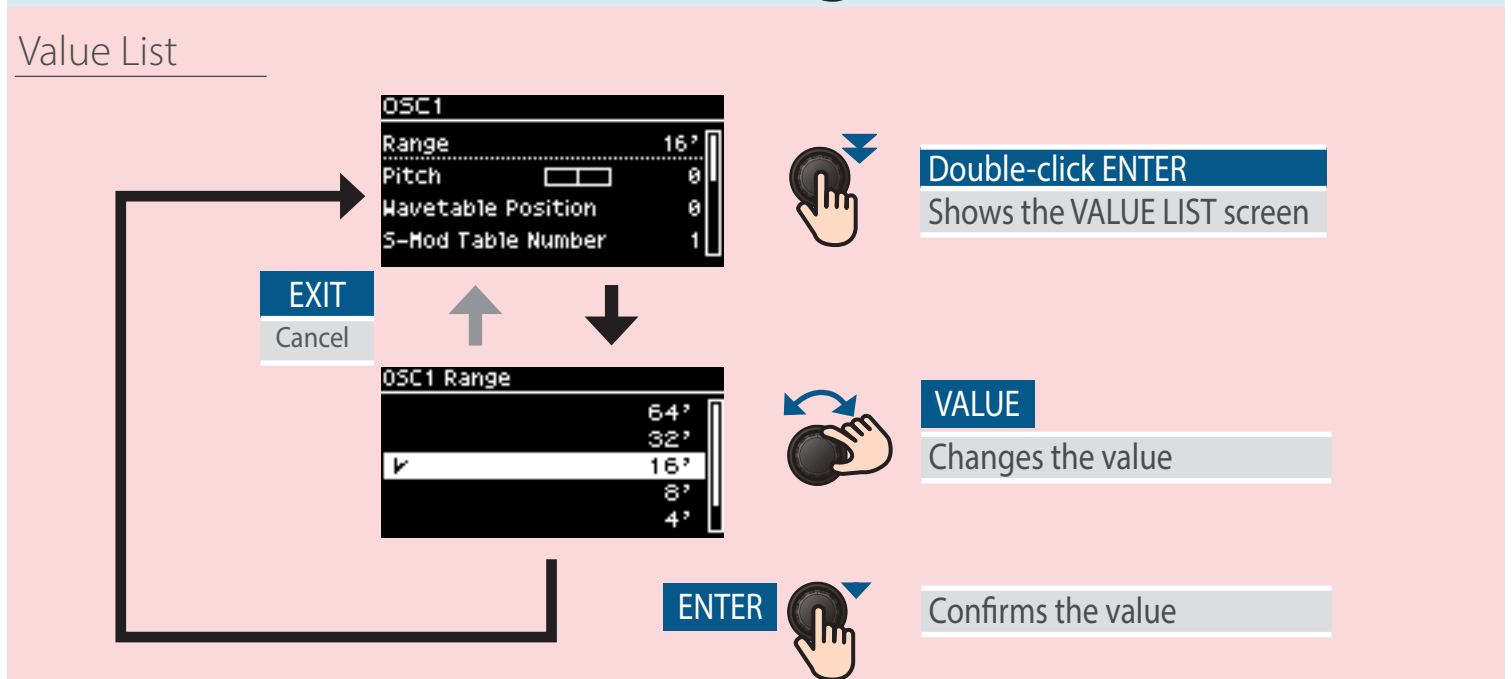
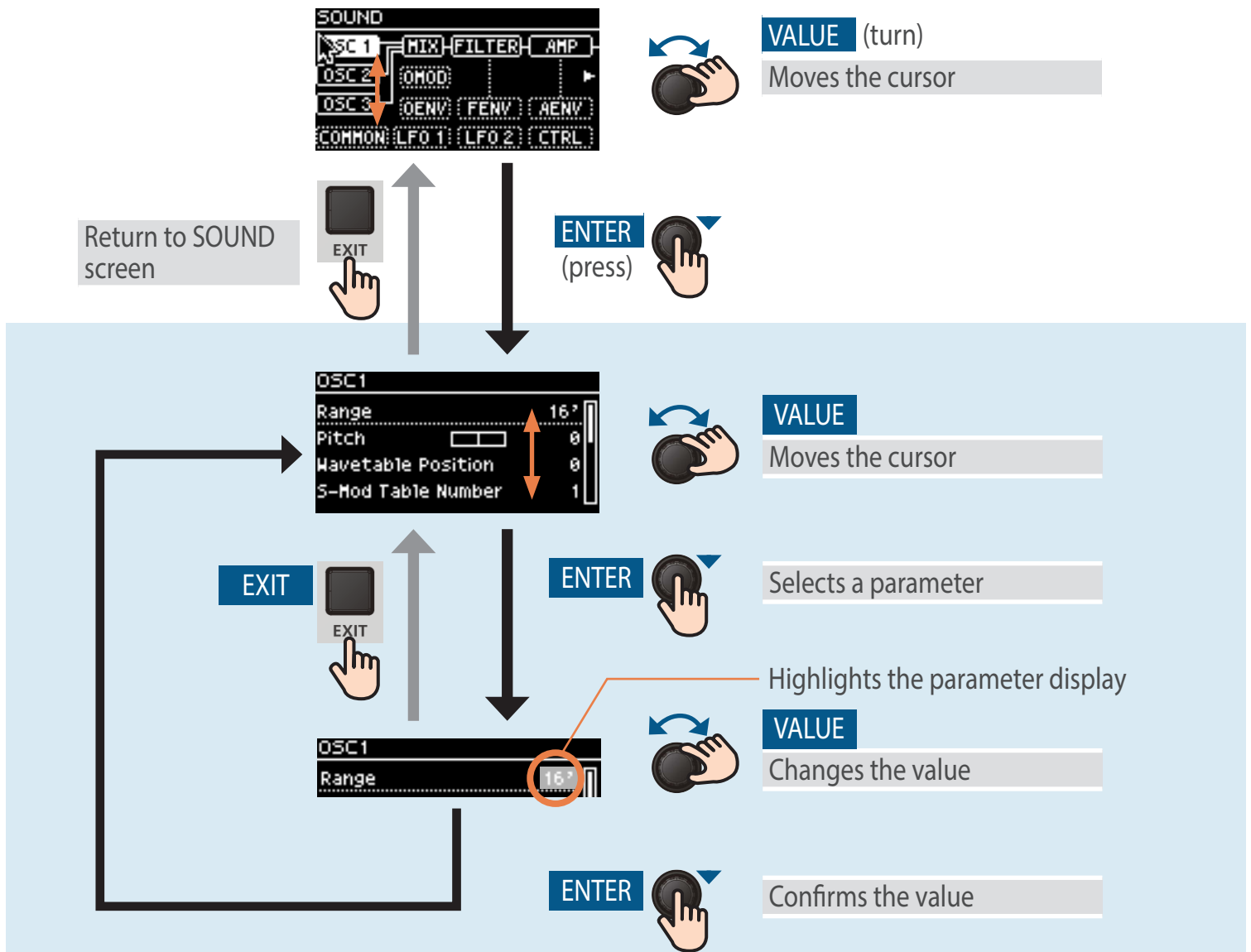

You can also use the motional pad to select parameters and edit their values.

This manual explains how to use the [VALUE] (ENTER) knob to operate this instrument.

- You can disable (turn off) the pad operations. → "Motional Pad UI Sw"
- When a parameter is selected, double-tap the motional pad to show the value list.
- Press the [EXIT] button to return to the previous screen or to cancel editing a value.
- Press the [EXIT] button a number of times to return to the TOP screen.

Pointer (circled in red) points to the 'OSC1' parameter in the SOUND screen.

Swipe (vertical and horizontal)
Moves the pointer

Swipe (right)
Return to SOUND screen

Tap

Swipe (vertical)
Moves the cursor

EXIT (button)

Tap

Selects a parameter

Highlights the parameter display

Swipe (vertical)
Changes the value

Swipe (horizontal)
Changes the value in larger units

Tap

Confirms the value

Value List

EXIT (button)
Cancel

Double-tap
Shows the VALUE LIST screen

Swipe (vertical)
Changes the value

Swipe (horizontal)
Changes the value in larger units

Tap

Confirms the value

On the GAIA-2, a single unit of sound is called a “tone”. There are four ways to classify tones: by attribute, by group, by bank number and by tone number.

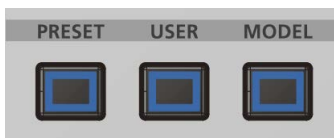
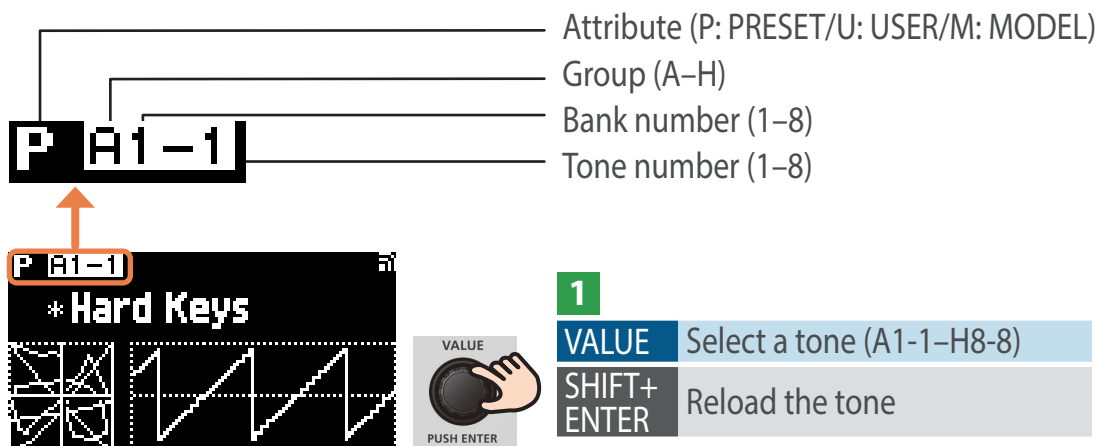

[PRESET] [USER] [MODEL] buttons
 Selects a tone attribute (three types).

1 PRESET	Selects a preset tone	Tones that can only be loaded, not overwritten
USER	Selects a user tone	Tones that can be loaded and overwritten
MODEL	Selects a model tone	Model expansion tones (SH-101 is preinstalled by factory default)

* Aside from the GAIA-2 original sound generator, the SH-101 Model Expansion comes preinstalled by factory default, which is modeled after Roland’s analog synthesizer. You can also install Model Expansions such as the JUPITER-8 and JUNO-106 from Roland Cloud (These are available for purchase). See the “GAIA-2 Roland Cloud User’s Guide” for details.

[1]–[16] buttons
 Selects the group, bank and tone numbers.

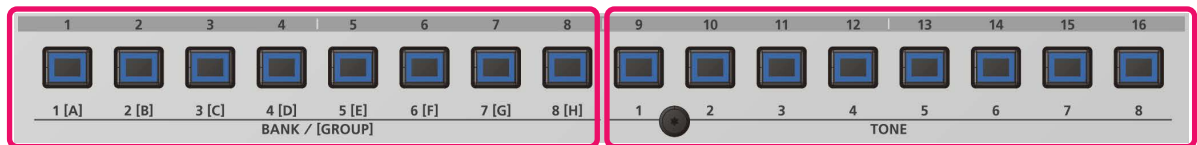

2 SHIFT+ 1-8	Selects the group (A-H)
3 1-8	Selects the bank number (1-8)
4 9-16	Selects the tone number (1-8)

Tone list

On the TONE LIST screen, you can select tones from a list of tone names. You can also filter and search for tones by category.

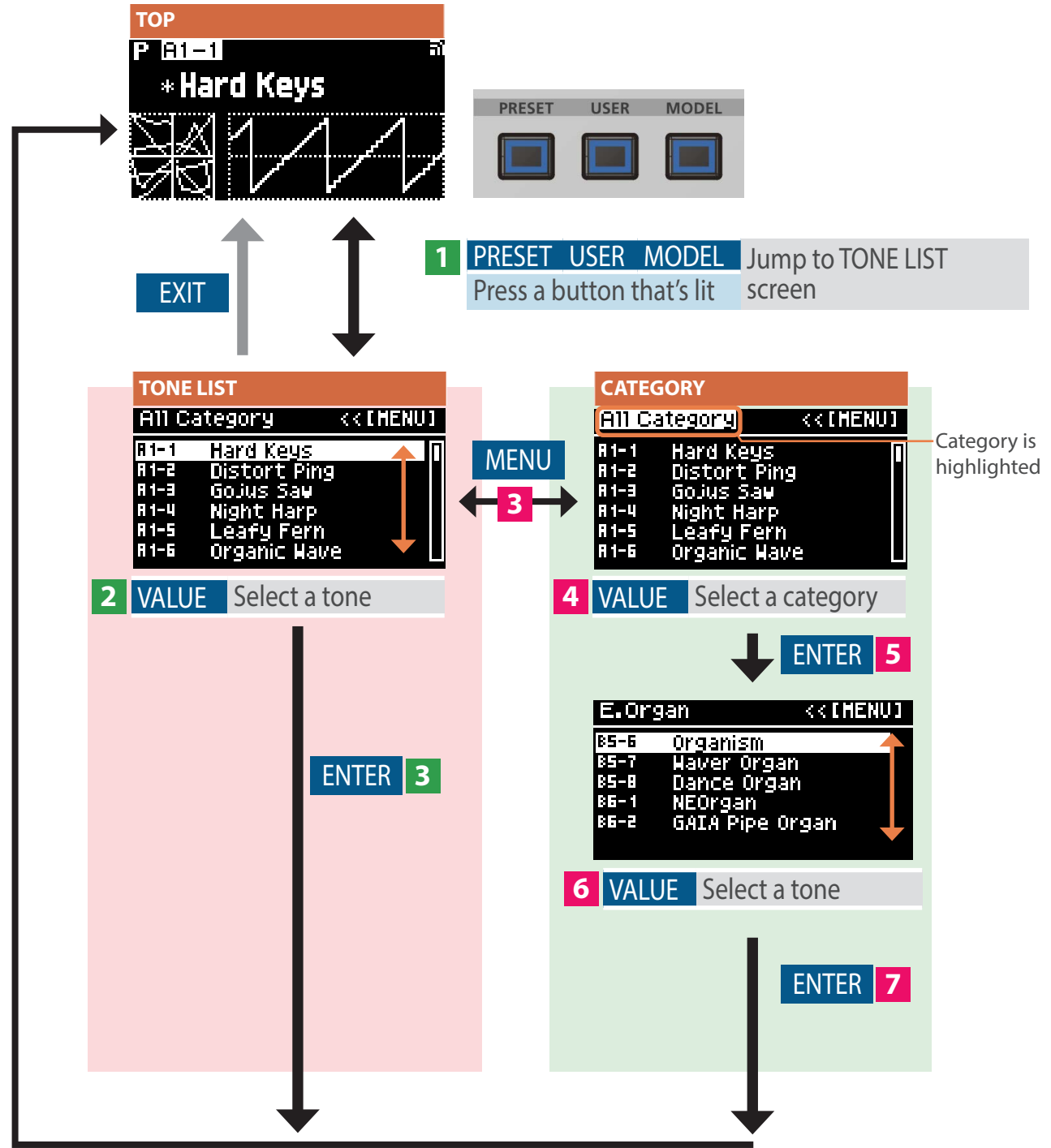

Tone write

The tones you edit as well as the original tones are saved as user tones.

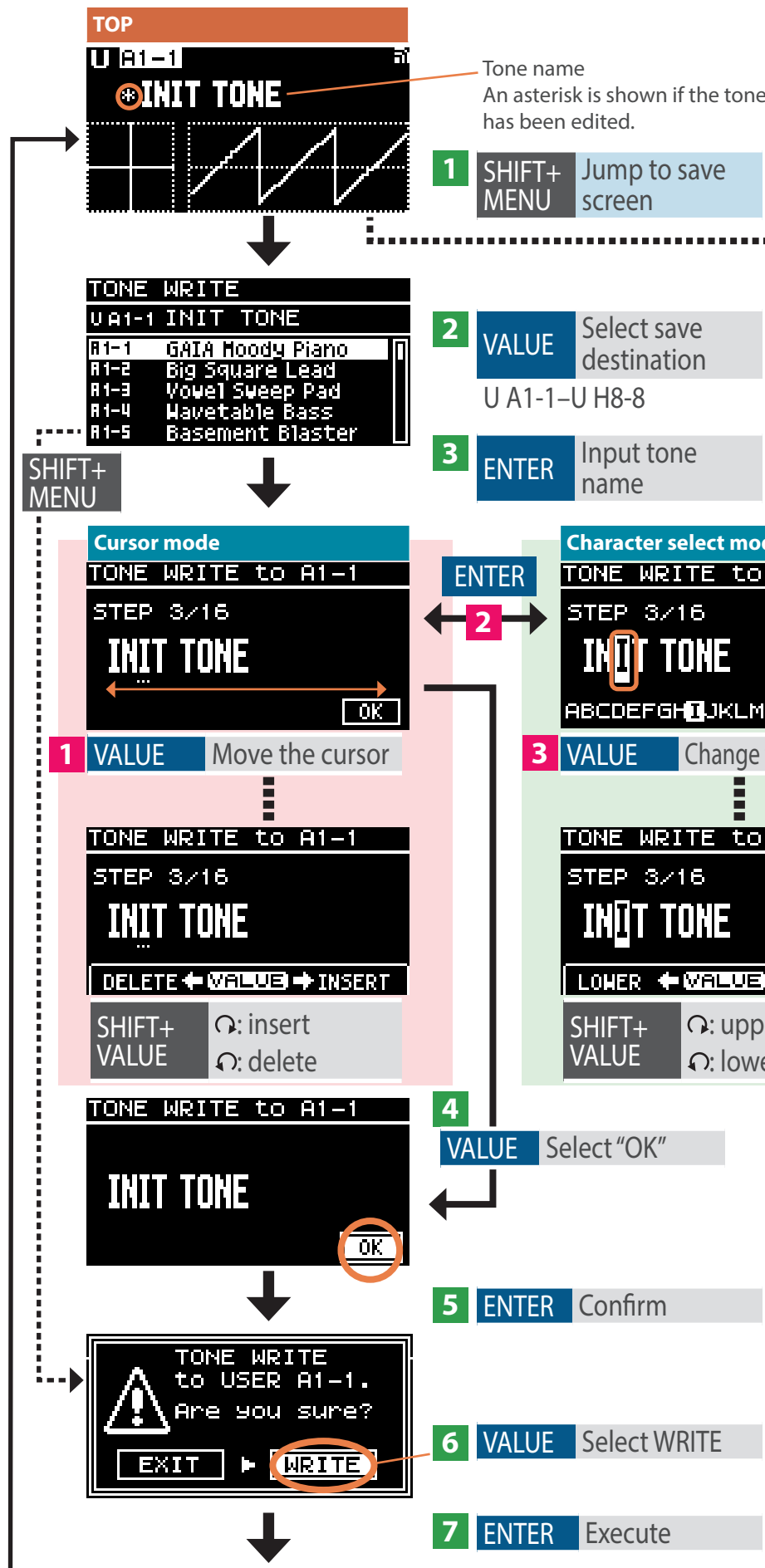

Tone init

Initializes the parameters for the tone.

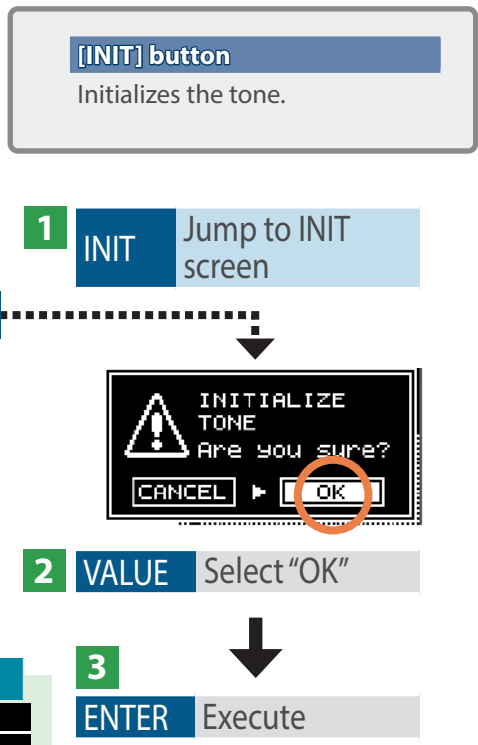

From the SOUND screen, you can edit the tones by accessing the EDIT screen for each section.

- Although you can normally use the knobs, sliders and buttons to directly edit a tone, you can edit more parameters by accessing each section from the SOUND screen (While you are operating the controls, the dedicated parameter popup windows or graphical popup windows appear on the TOP screen for the relevant parameter).
- You can directly jump to the related EDIT page by operating the knobs and sliders while pressing the [MENU] button.
- When you operate a knob or slider while holding down the [EXIT] button, you can check the current value of the parameter in question.

Basic operation

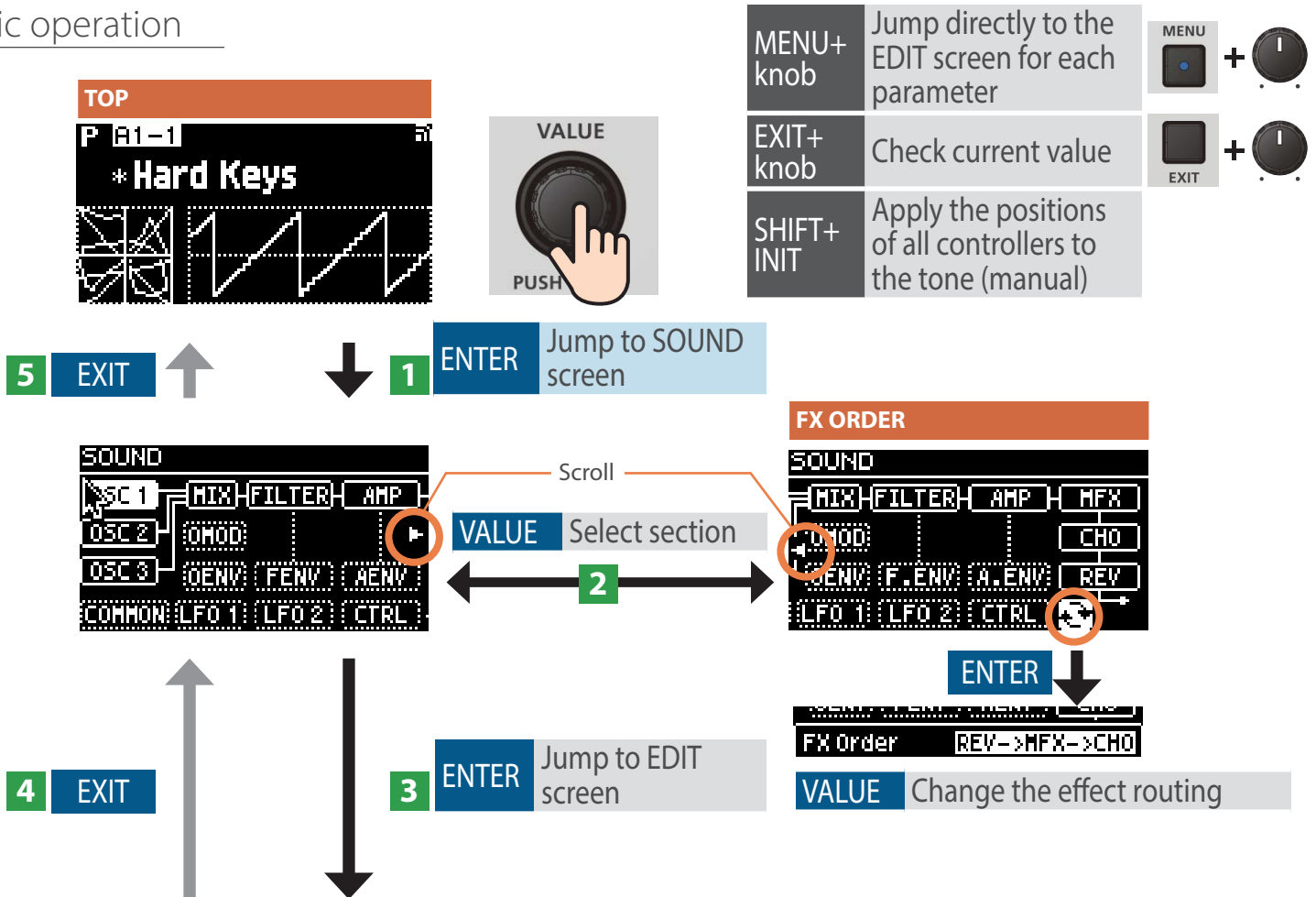

EDIT screen operations shared in common (select parameter and change value)

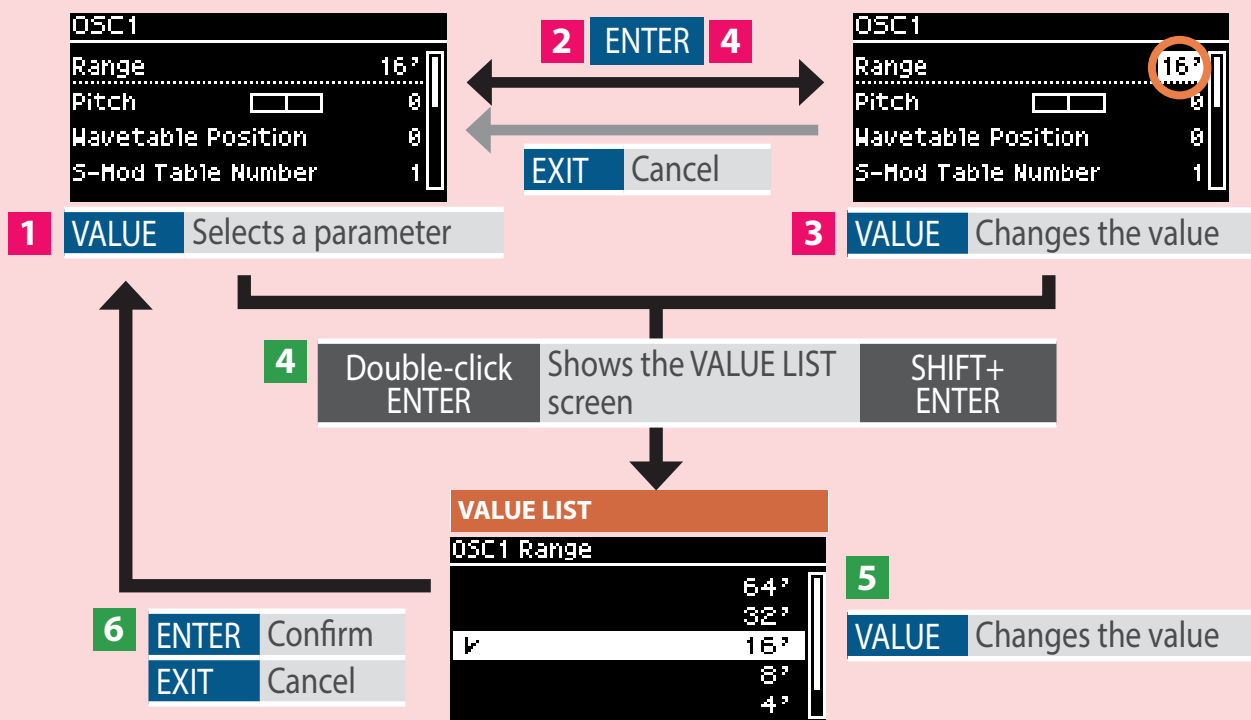

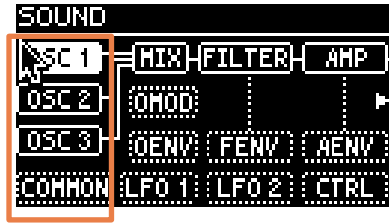

OSC

This sets the waveform used as the base sound. OSC 1 outputs a wavetable waveform, and OSC 2/3 outputs a standard synthesizer waveform.

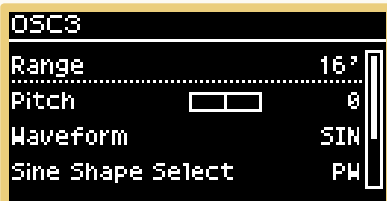
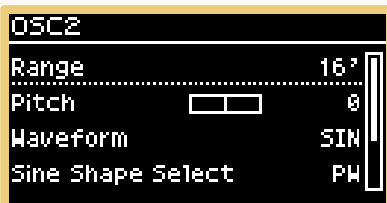
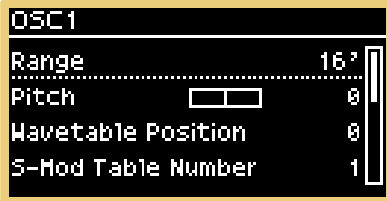

OSCILLATORS

[RANGE] knob

Adjusts the range of the oscillator.

[PITCH] knob

Adjusts the pitch of the oscillator.
+ [SHIFT]: Adjusts the pitch in semitones.

[TABLE] knob (OSC 1)

Selects the wavetable.

[WAVE] knob (OSC 2 / OSC 3)

Selects the oscillator waveform.

[POSITION] knob (OSC 1)

Adjusts the position in the wavetable.

[SHAPE] knob (OSC 2 / OSC 3)

Adjusts the waveform shape.

COMMON

This configures the overall settings, such as how the tones are played.

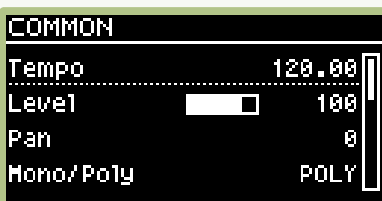

VOICE

[MONO] button

Switches between mono and poly mode.

[PORTAMENTO] knob

Adjusts the portamento time.
Turn the knob all the way counterclockwise to turn the portamento off.

[CHORD] button

Turns the chord memory on/off.

[HOLD] button

Switches the hold on/off.
While this is on, the notes you play keep sounding even after you take your fingers off the keyboard.

TEMPO

[TEMPO] knob

Adjusts the tempo.

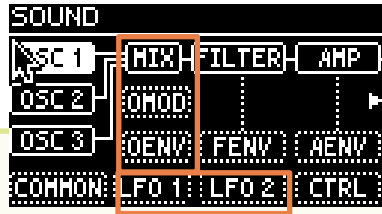

MIX/OMOD/OENV

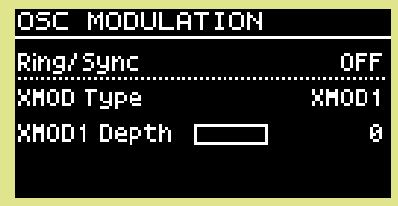
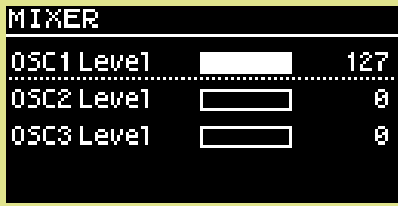

This sets the volume, modulation and changes over time (envelope) for each oscillator.

MIXER

[OSC 1] [OSC 2] [OSC 3] knobs

Adjusts the volume of each oscillator.

OSC MOD

[XMOD] knob

Adjusts the depth of cross-modulation.

[SYNC] button

Turns the oscillator sync on/off (+ [SHIFT]: ring modulator).

OSC ENVELOPE

[ENV DEPTH] knob

Adjusts the pitch envelope intensity.

[A] [D] knobs

Adjusts the pitch envelope.

LFO

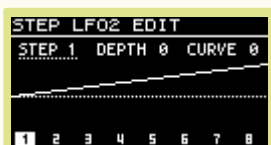
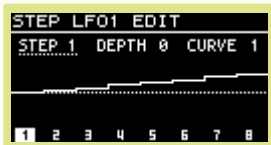
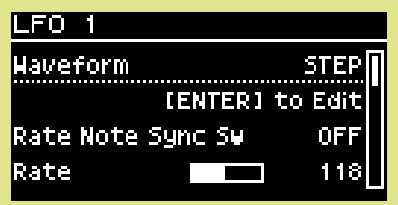

This configures the cyclical change applied to the tone. Operate the control that applies the effect, while holding down the [ASSIGN] button to set the target.

LFO 1 / LFO 2

[RATE] knob

Adjusts the LFO's modulation speed.

[TEMPO SYNC] button

When this is turned on, the LFO cycle is synchronized with the tempo.

[WAVE] knob

Selects the LFO waveform.

[DEPTH] knob

Adjusts the depth of the LFO.

[ASSIGN] button

Sets where the LFO is applied to (assign 1-4).

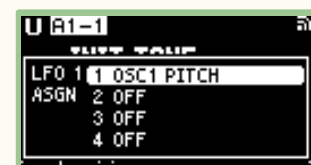

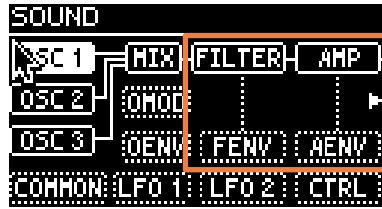

FILTER

Adjusts the frequency components of the tone. Use this section to create various sounds by making time-based changes with the envelope.

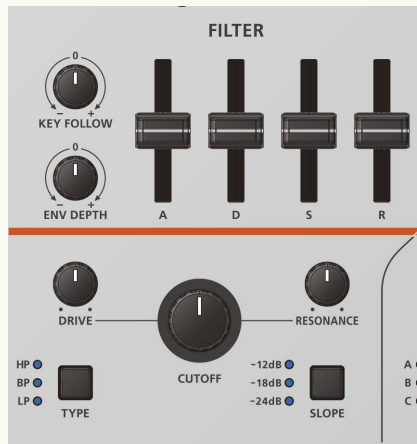
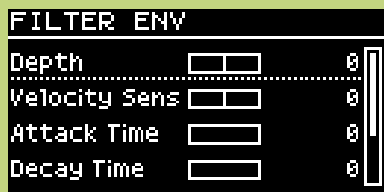
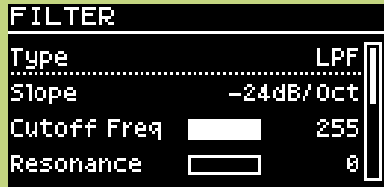

FILTER

[KEY FOLLOW] knob

Adjusts the cutoff key follow.

[ENV DEPTH] knob

Adjusts the filter envelope intensity.

[A] [D] [S] [R] sliders

Adjusts the filter envelope.

[DRIVE] knob

Adjusts the degree of oscillator distortion.

[TYPE] button

Sets the type of filter.

[CUTOFF] knob

Adjusts the cutoff frequency.

[RESONANCE] knob

Adjusts the resonance.

[SLOPE] button

Sets the filter slope.

AMP

Adjusts the tone volume. Use this section to create various sounds by making time-based changes with the envelope.

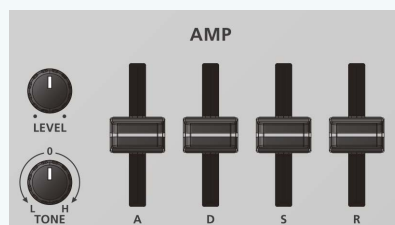
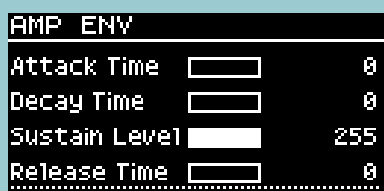

AMP

[LEVEL] knob

Adjusts the overall volume for all tones.

[TONE] knob

Adjusts the tonal character of the tone.

[A] [D] [S] [R] sliders

Adjusts the amp envelope.

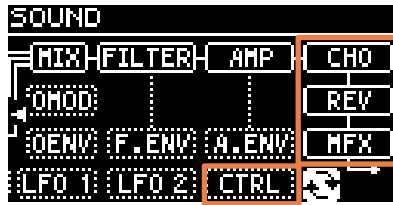

CTRL

Sets how each controller works.

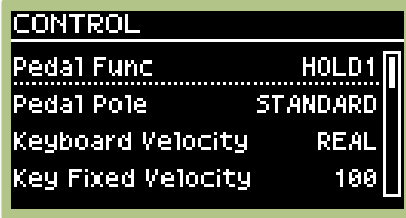

PITCH wheel

Changes the pitch. Move the wheel down (towards you) to lower the pitch, and move the wheel up (away from you) to raise the pitch. When you take your finger off the wheel, it returns to the center position.

[VELOCITY] button

When this is on, you can control the dynamics via key touch.

[TRANPOSE] button

Hold down this button and use the OCTAVE [DOWN] [UP] buttons to raise or lower the pitch range in semitone steps.

* This setting is not stored in the tones.

OCTAVE [-] [+] buttons

Raises or lowers the pitch range in steps of an octave.

* This setting is not stored in the tones.

MOD wheel

Adds vibrato to the sound. When you move the wheel all the way down (towards you), no effect is applied. The further the wheel is moved up (away from you), the greater the effect. The wheel doesn't return to its previous position even after releasing your finger.

EFFECTS

This configures the effects that add various tonal color.

MFX



MFX

[ON/OFF] button

Turns the MFX on/off.

[TYPE] knob

Sets the MFX type.

[CTRL 1]–[CTRL 3] knobs

These adjust the MFX parameters. The parameters to change depend on the effect type.

REV

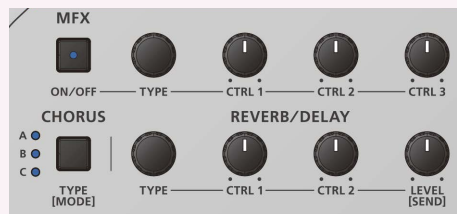

CHORUS

[TYPE] button

Sets the chorus type.

REVERB/DELAY

[TYPE] knob

Sets the reverb/delay type.

[CTRL 1] [CTRL 2] [LEVEL] knobs

Adjusts the reverb/delay parameters. The parameters to change depend on the effect type.

CHO

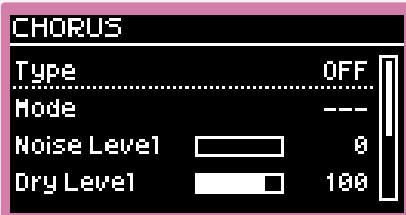

You can assign up to four parameters respectively to LFO 1 and LFO 2.

- Operate a knob or slider while holding down the [ASSIGN] button to assign that parameter (You can also set this from the LFO EDIT screen).
- The P-MOD (Phase Modulation) and S-MOD (Shaping Modulation) parameters can be assigned using the motional pad.
- Refer to this list for the assignable parameters. → "Panel parameter assignment list"

Example: assigning parameters for the knobs and sliders

Example: assigning P-Mod and S-Mod parameters

* This explanation is based on P-Mod as an example. For S-Mod, access the S-MOD EDIT screen first and then make the settings.

1 ASSIGN Selects ASSIGN 1-4

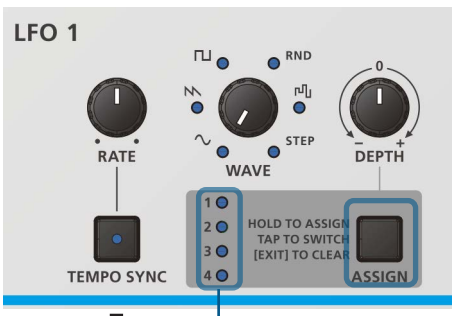

Current assign number lights up

2 Long-press ASSIGN

1 ASSIGN Selects ASSIGN 1-4
2 P-MOD Jump to P-MOD EDIT screen

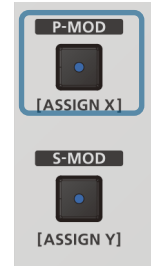
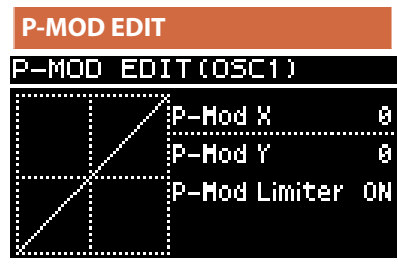

3 Long-press ASSIGN

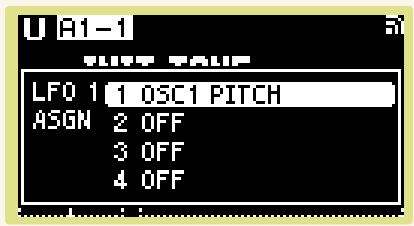

- 3**
- | | |
|---------------|--------------------------------|
| ASSIGN+ knob | Assigns the parameter used |
| ASSIGN+ VALUE | Assigns the parameter selected |
| ASSIGN+ EXIT | Clears the assignment |



4 Release ASSIGN

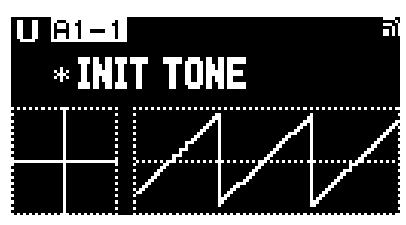

- 4**
- | | |
|--------------------------|-----------------------|
| ASSIGN+ PAD (horizontal) | Assigns P-Mod X |
| ASSIGN+ PAD (vertical) | Assigns P-Mod Y |
| ASSIGN+ EXIT | Clears the assignment |

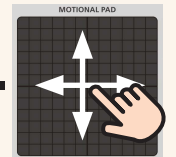

5 Release ASSIGN

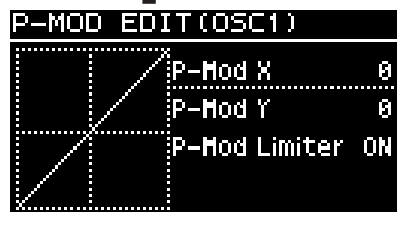

By setting the waveform for LFO 1/LFO 2 to "STEP", you can combine up to 16 steps of curves to create your own LFO waveform. You can use the settings screen to graphically view the time-based changes in the parameters for editing.

Basic operation

Shortcut

You can also access the following shortcuts from the STEP LFO EDIT screen.

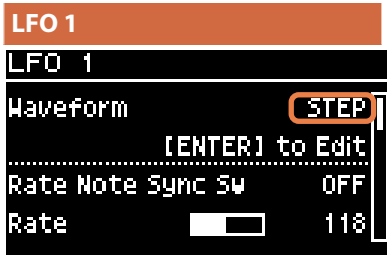

1 VALUE Select STEP for the waveform



2 VALUE Select [ENTER] to edit

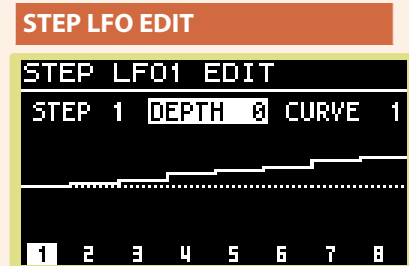

- 3 1-16** Changes the current step
- SHIFT+ 1-16** Edits the step length
- PAD X** edits the current step
- Operation Y** edits the depth



1 WAVE Select STEP

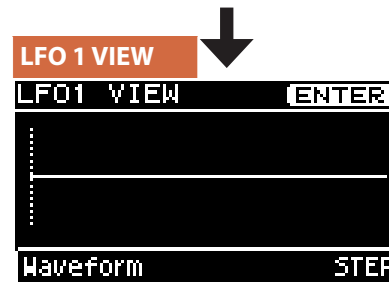

VIEW screen appears

2 ENTER Press ENTER while the VIEW screen is shown

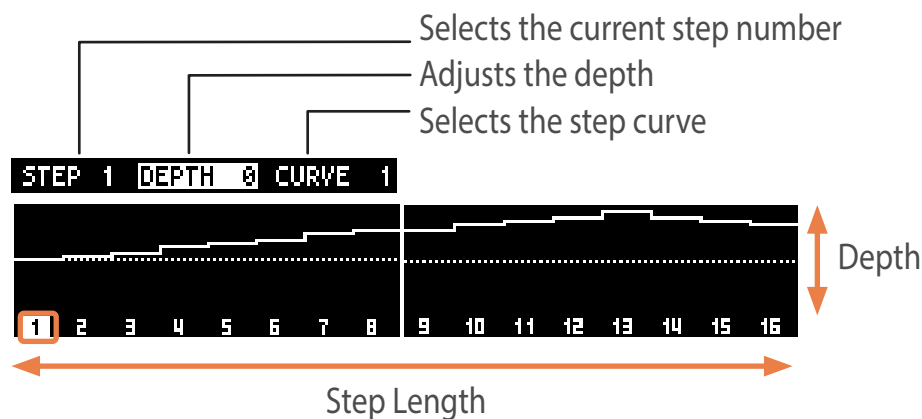

* Refer to this list for the types of step curves. → "Step Curve 1-16"

You can assign any parameter on the panel to the X and Y axes of the motional pad for real-time control.

- When you control a parameter from the motional pad, this is applied as an offset to the original value (The pad center values are (0, 0)).
- You can save the motions you play on the motional pad (motion rec), and play these motions back at different speeds (motion play).
- Motions and settings are stored for each tone.
- The motional pad position (where you touch the pad) is not stored in the tones.
- You can also select a motion from a template.
- The motional pad sensitivity can be changed. → "Motional Pad Sens"

<p>MOTIONAL PAD</p> <p>[P-MOD] button Shows the P-MOD EDIT screen. +SHIFT: Shows the MOTION ASSIGN-X screen.</p> <p>[S-MOD] button Shows the S-MOD EDIT screen. +SHIFT: Shows the MOTION ASSIGN-Y screen.</p>	<p>MOTIONAL PAD Controls the assigned parameter.</p>	<p>MOTIONAL PAD</p> <p>[REC] button Shows the MOTION REC screen.</p> <p>[ON/OFF] button Plays/stops the recorded motion.</p>
--	---	---

Motion rec

5 EXIT

1 MOTION REC

2 Operate the pad

3 Release the pad

4 MOTION REC

SHIFT+ MOTION REC Clear the recorded motion

MOTION REC Motion rec standby

VALUE Select [TEMPLATE]

ENTER Jump to MOTION TEMPLATE screen

MOTION REC Starts motion rec

Release the pad Ends motion rec

MOTION TEMPLATE Motion template standby

1 MOTION TEMPLATE

2 VALUE Sets the start point of the shape

SHIFT+ VALUE Sets the start point of the shape

EXIT Cancel

3 ENTER Turns the motion on and moves the screen

MOTIONAL PAD ON/OFF

Reset the position

* To reset the position, press the MOTIONAL PAD [ON/OFF] button while using a tone that doesn't contain recorded data for the motional pad.

Automatically plays the recorded motion.

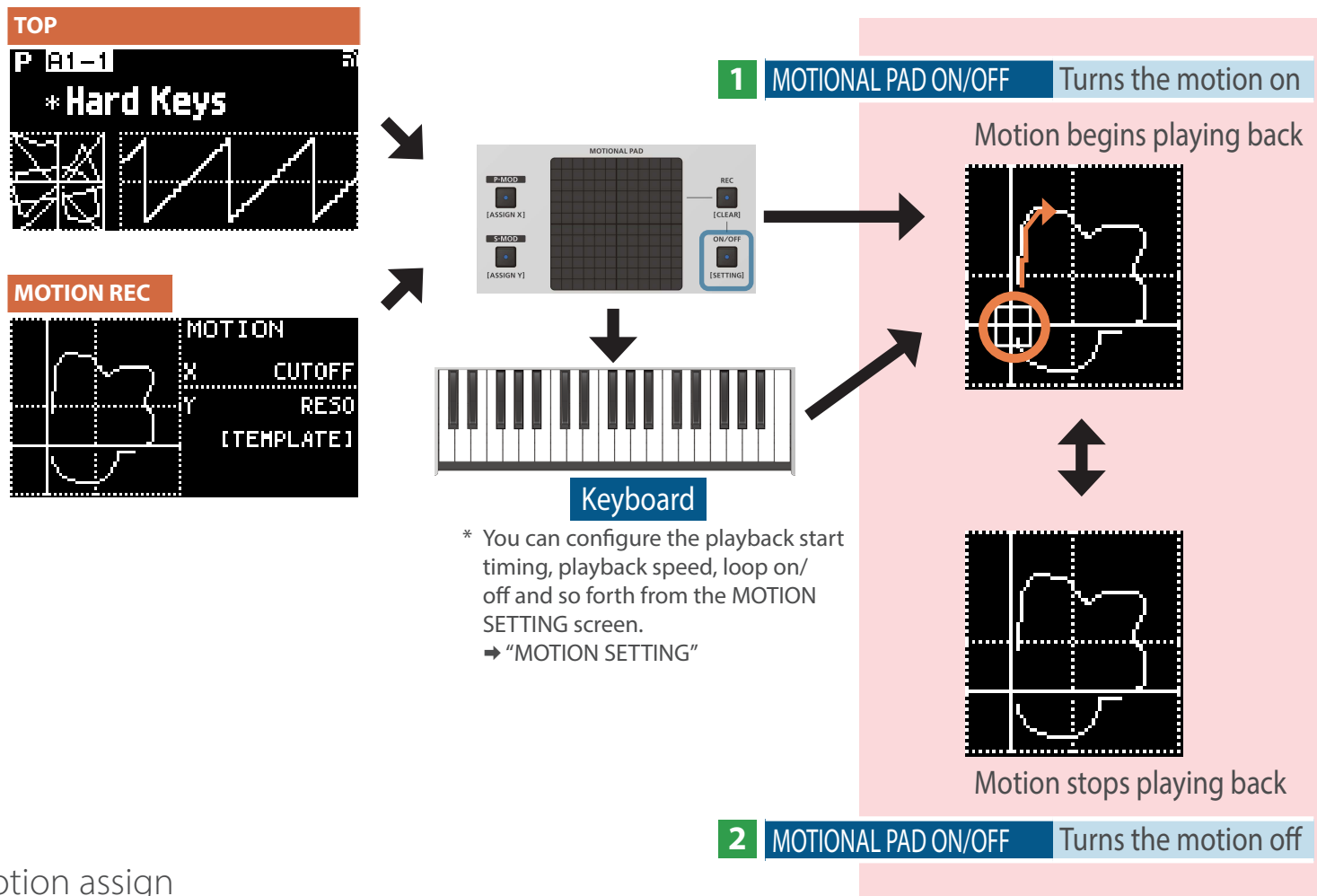

Motion assign

Assigns parameters to the X and Y axes of the motional pad.

- You can assign these parameters while the MOTION ASGN-X (or Y) screen is shown by operating a knob or slider (You can also set this from the MOTION SETTING screen).
- Refer to this list for the assignable parameters. → "Panel parameter assignment list"

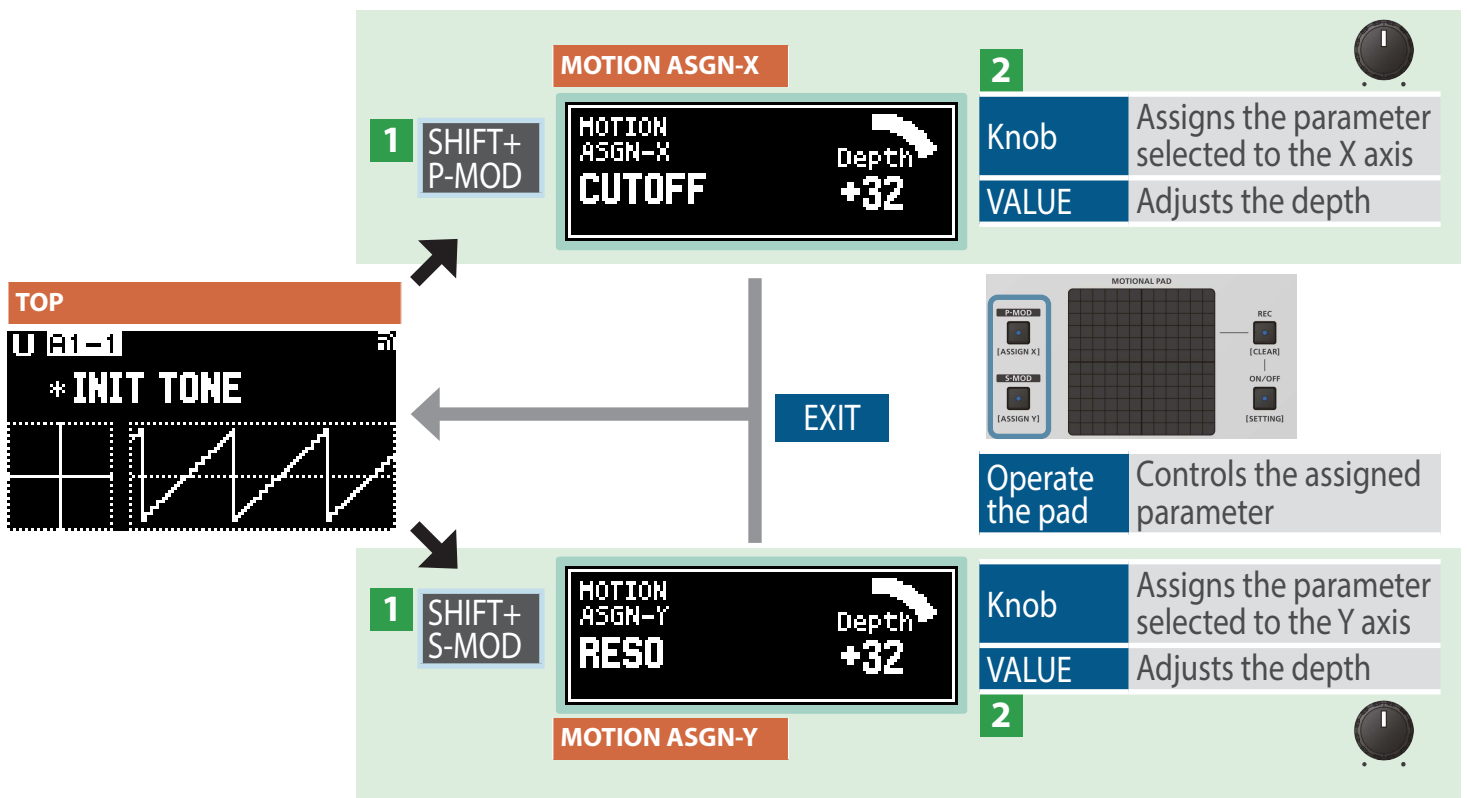

You can modulate the OSC 1 (Wavetable OSC) waveform using either P-Mod (Phase Modulation) or S-Mod (Shaping Modulation).

- When the indicators of either the P-Mod or S-Mod button are lit, the pad controls the direct value (not the offset value) of the parameter in question for OSC 1.
- Press the MOTIONAL PAD [REC] button while the indicator is lit to assign the parameter of either P-Mod or S-Mod to the motional pad.

When the dialog box shown below appears, select "OK" and press the [VALUE] (ENTER) button to go to motion rec standby with the parameter assigned.

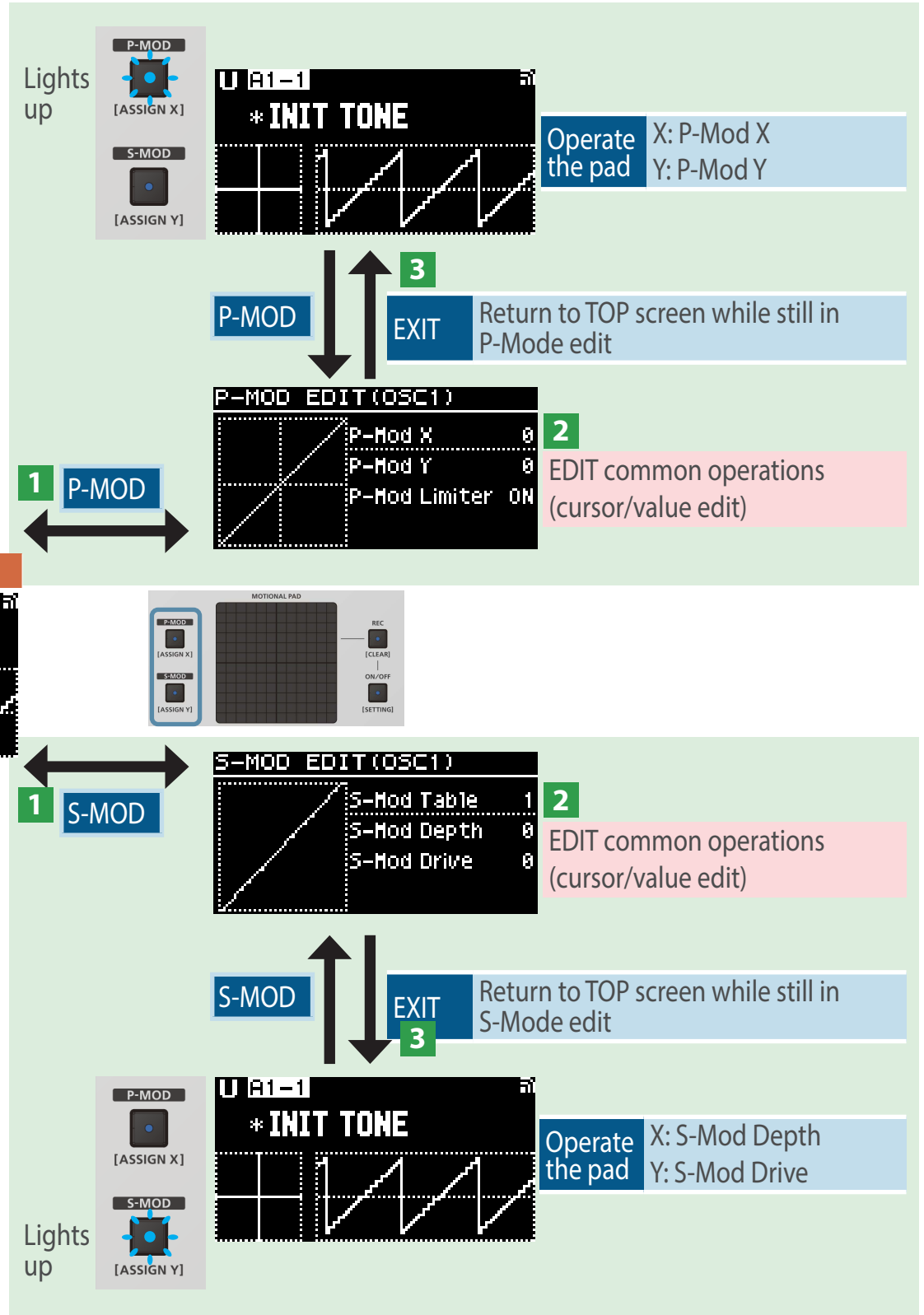

Wavetable OSC

The Wavetable OSC features a varied collection of single-cycle waveforms called a “table”. Different waveforms are arranged in continuous order inside the table, and you can specify the position from which to begin playback to play unique sounds whose waveforms change in various ways over time.

Wavetable (example)

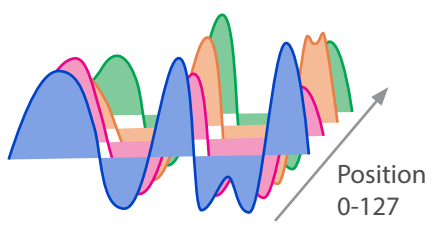

Phase Modulation

Phase modulation is used to alter the output waveform by modulating the phase of the input waveform. By increasing the phase of even a simple input waveform, you can make dramatic changes to the waveform to get a distinctive tone.

Relationship between phase modulation X/Y and the waveform

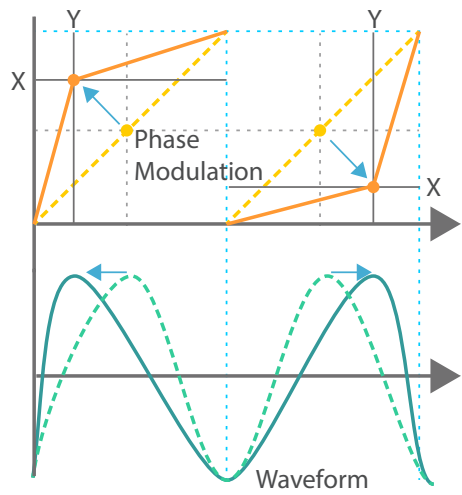

Shaping Modulation

With shaping modulation, you can modulate the input waveform signal using a waveform table called a “shaper”. The more complex the shaper is, the greater the change you can make, even to simple input waveforms. This lets you make tones that are rich in high-frequency components.

Relationship between the shaping modulation table and the waveform

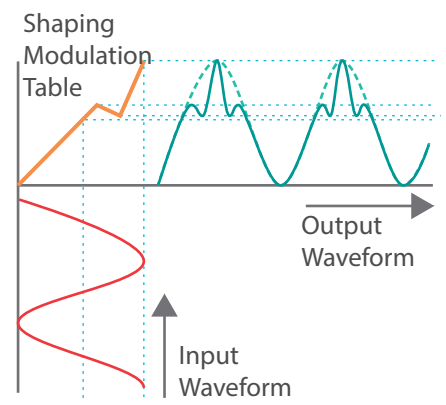

Motion settings

Here’s where you configure the motion-related settings.

TOP

* INIT TONE

3

EXIT

↑

1

SHIFT+
MOTION ON/OFF

↓

Jump to MOTION
SETTING screen

MOTION SETTING

Motion	OFF
Speed	+1.0
X	CUTOFF
Y	RESO

2

EDIT common operations
(cursor/value edit)

Edits the setting

This feature lets you play arpeggios simply by pressing the keys.

- Both the notes you input on the keyboard and the notes outputted from the sequencer are inputted to the arpeggiator. This lets you create complex sequences that include arpeggio playing.

ARPEGGIO	[SCALE] knob
[ON] button Turns the arpeggio on/off.	Sets the scale of the arpeggio.
[MODE] knob Sets the mode of the arpeggio.	[TEMPO] knob Adjusts the tempo.

Arpeggio play

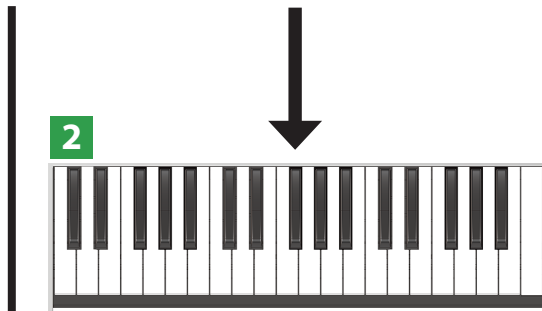
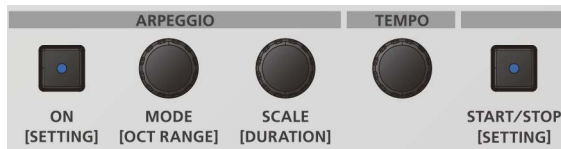

1	ARPEGGIO ON	Arpeggio on/off
	MODE	Selects the mode
	SCALE	Adjusts the scale
	SHIFT+MODE	Adjusts the octave range
	SHIFT+SCALE	Adjusts the duration
	Keyboard	Plays the arpeggio
	HOLD	Holds the arpeggio playing back
	TEMPO	Tempo of the arpeggiator/sequencer

Arpeggio settings

1 SHIFT+ARPEGGIO ON

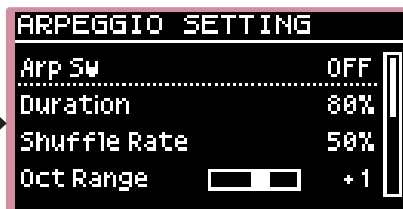

3 EXIT

SHIFT+ARPEGGIO ON Jump to ARPEGGIO SETTING screen

2 EDIT common operations (cursor/value edit)
Edits the setting

You can use the chord memory feature to play entire chords that you've registered beforehand, simply by playing a note on the keyboard.

- The chord is transposed according to the keys you play.
- You can record the chords you play using chord memory into the sequencer.
- The chord memory settings are stored for each tone.

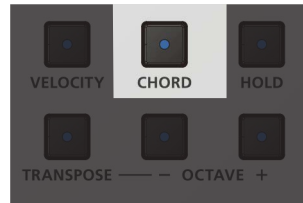

[CHORD] button

Turns the chord memory on/off.
The button lights up when on.
Long-press the button to register a chord.

Chord memory play



1 3

CHORD Turn the chord memory on/off

* The button lights up when on.

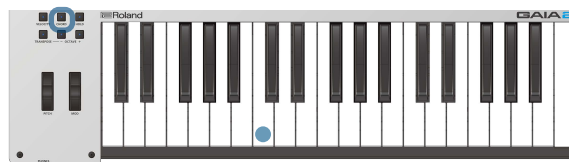

2 **Keyboard** Plays chords

Chord memory input



3 **Release CHORD** Finishes registering chord and turns chord memory on

1 **Long-press CHORD**

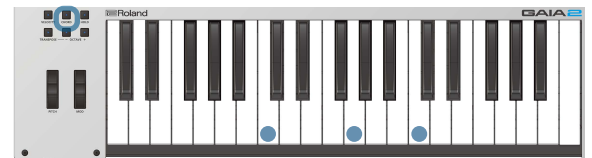

2 **Keyboard** Play a chord on the keyboard to register

- * Play a chord while pressing [CHORD].
- * The registered note number is shown onscreen.
- * You can register up to eight notes.



This is a pattern sequencer that lets you record up to 64 steps. Two types of recording are available, real time and step.

- Patterns are stored for each tone.

SEQUENCER

[START/STOP] [REC] [TIE] [REST] [EDIT] buttons

These buttons configure the sequencer settings.

[1]–[16] buttons

These buttons indicate the steps. When the TONE LIST screen is shown during pattern playback, the [1]–[16] buttons revert to tone switching buttons, letting you change tones in real time while the pattern plays.

Basic operation

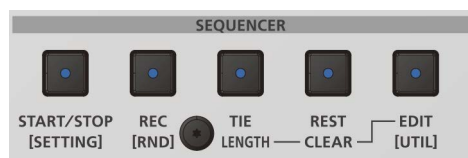

START/STOP	Play/stop pattern
REC	Jump to REC STANDBY screen
EDIT	Jump to EDIT screen
SHIFT+ REC	Jump to RANDOM PATTERN screen
SHIFT+ EDIT	Jump to SEQUENCER UTILITY screen
SHIFT+ START/STOP	Jump to SEQUENCER SETTING screen
EDIT+ REC	Undo/redo

* Reverts to the previous recording operation (undo). Press the button again to go back to the original state (redo).

Sequencer settings

Here's where you configure the sequencer-related settings.

This setting is stored for each pattern.



SHIFT+ START/STOP	Jump to SEQUENCER SETTING screen
-------------------	----------------------------------

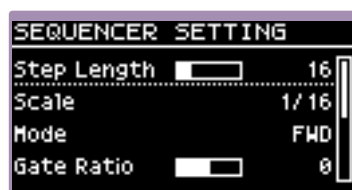

- EDIT common operations (cursor/value edit)
Edits the setting

Plays the pattern.

- You can mute steps during playback, as well as change the step playback range to vary the pattern.

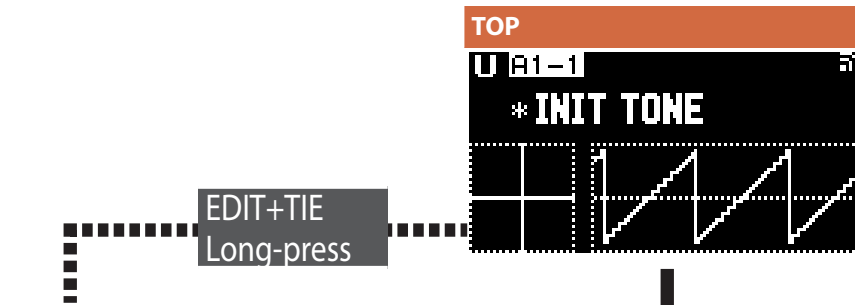

Operate the pad Change first/last step

* You can change the step playback range (first/last step) by operating the motion pad while holding down the [EDIT] and [TIE] buttons during pattern playback. Release the buttons to turn the setting off.

Random pattern

Specifies a parameter to generate a random pattern.

- You can also execute this while a pattern is playing back.
- You can't generate chords using the random pattern function.

START/STOP Play/stop pattern

* The [1]–[16] buttons blink according to the playback position.

Keyboard Transpose the pattern

* Set Play/Trans to "ON" in the SEQUENCER SETTING screen.

TEMPO Sequencer/arpeggio tempo

- SHIFT+1 Move to page (STEP 1–16)
- SHIFT+2 Move to page (STEP 17–32)
- SHIFT+3 Move to page (STEP 33–48)
- SHIFT+4 Move to page (STEP 49–64)

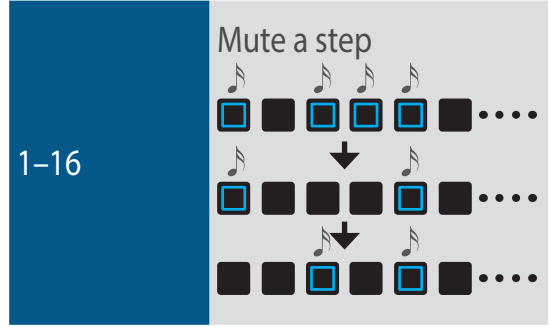

- * Press the [1]–[16] buttons that are lit to mute them (the buttons go dark). Press the buttons again to unmute the steps.
- * You can also mute steps while a pattern is playing back.
- * The buttons revert to tone switching buttons when the TONE LIST screen is shown.

SHIFT+REC Jump to RANDOM PATTERN screen

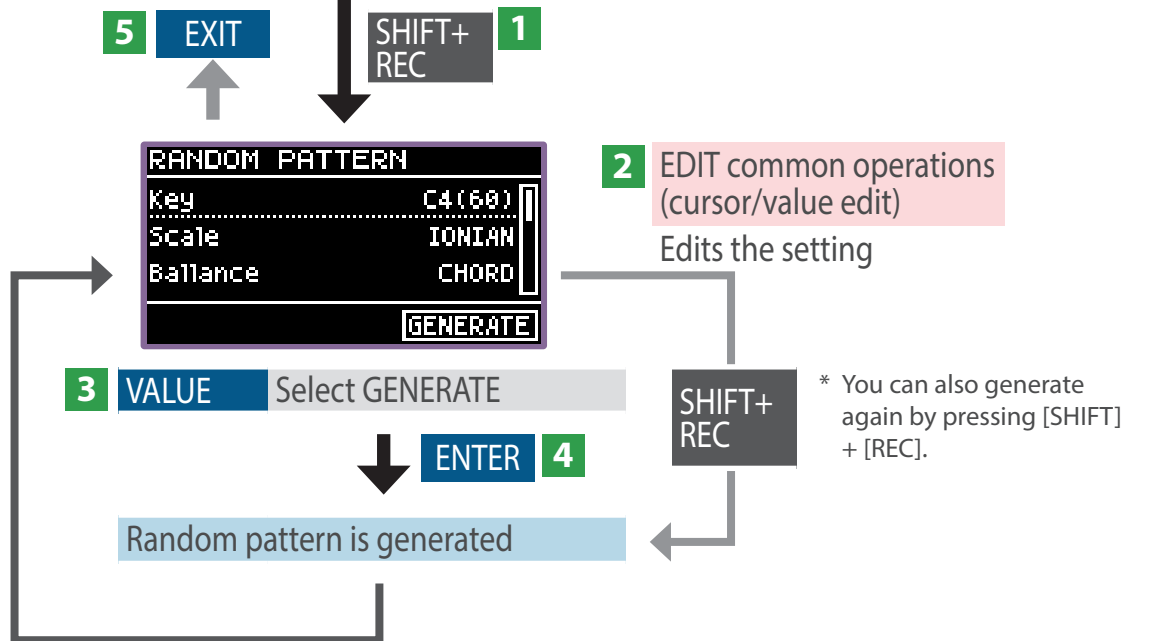

This recording method lets you record loops by playing the keyboard or controllers in real time while listening to the click sound.

- You can seamlessly switch between realtime rec and pattern play without stopping the pattern playback.
- You can clear (delete) part of the data you recorded.
- Refer to the list for the parameters for which motions can be recorded. → “Panel parameter assignment list”

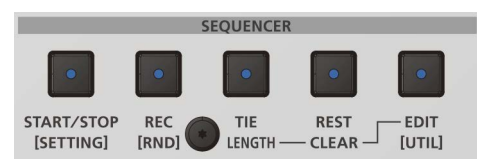
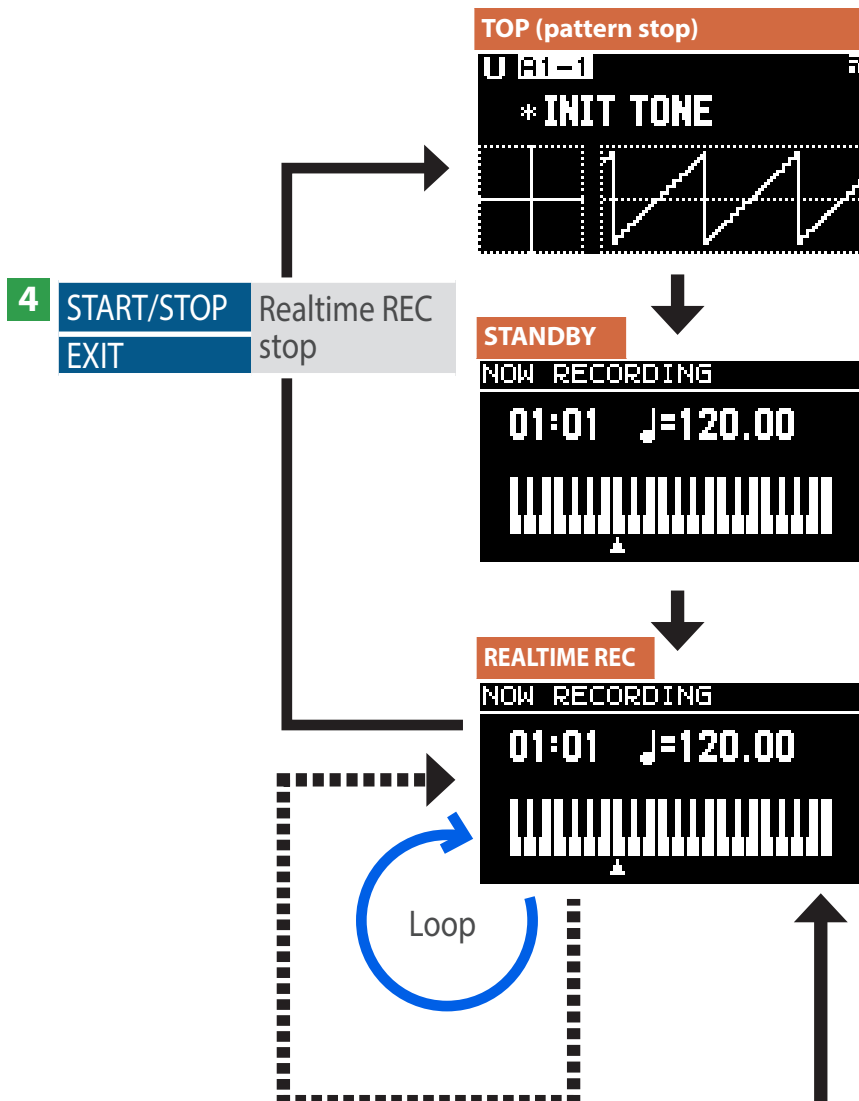

4 START/STOP
EXIT
Realtime REC stop

1 REC
Jump to REC STANDBY screen

* The [1]-[16] buttons operate in sequencer-only mode during recording.

2 START/STOP
Realtime REC start
* The count-in sounds before recording starts.

3 Keyboard Note input
Knob Input motion (control change message)
Sliders

- * Realtime rec is loop recording.
- * Overdubbing is possible.
- * The [1]-[16] buttons corresponding to the steps that contain inputted notes light up.

REC
Switch between realtime rec/pattern play

EDIT+ REST
Long-press
Clear Step

* Long-press [REST] while long-pressing [EDIT] to clear the data inputted into the steps that play while you're holding down the buttons.

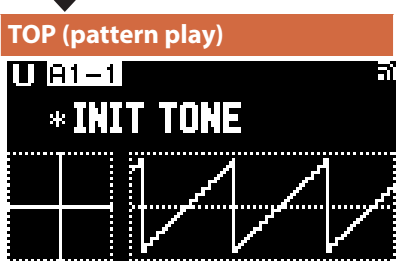
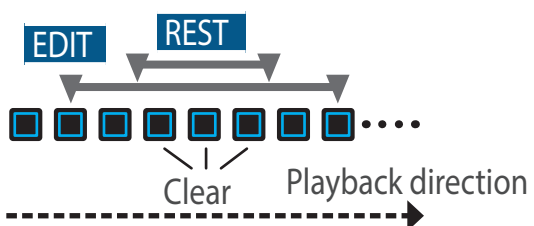

This recording method lets you play the keys to specify the order of the note pitches.

- Aside from notes, you can also record the values of knobs and sliders (as a motion) for the specified steps.
- The current input position is called the “current step”.

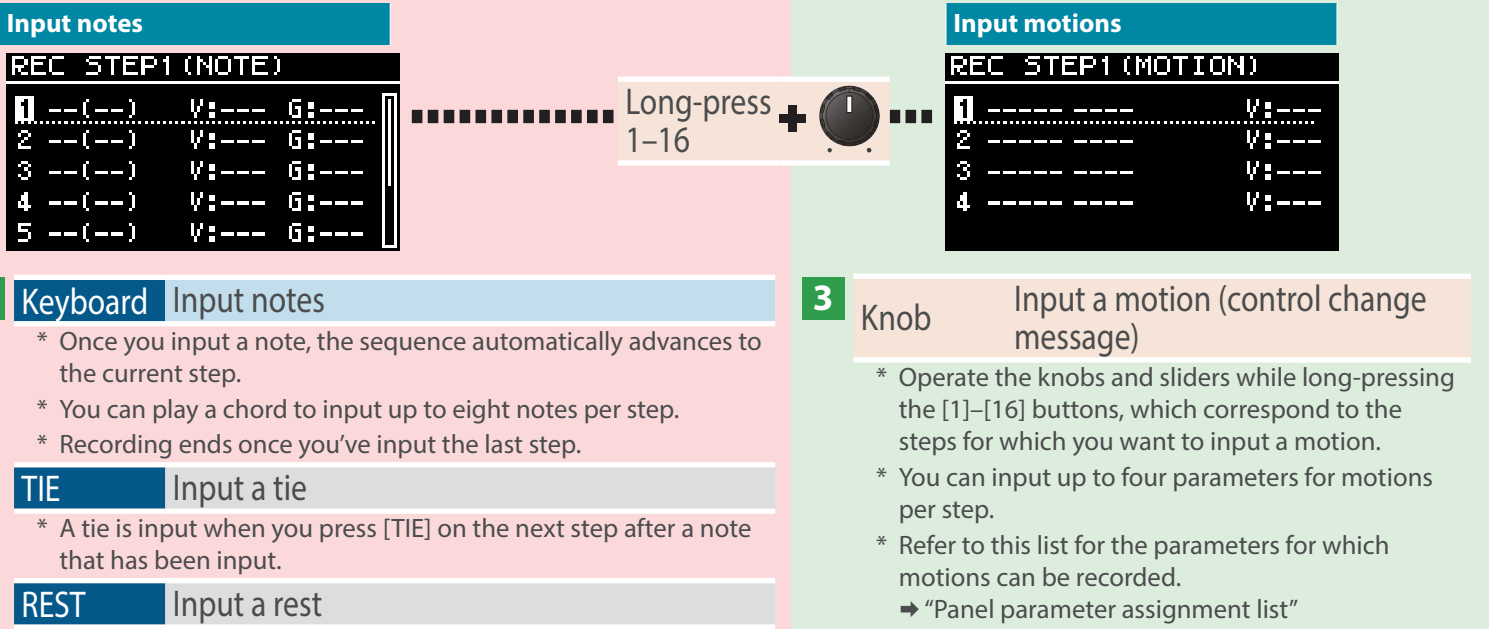
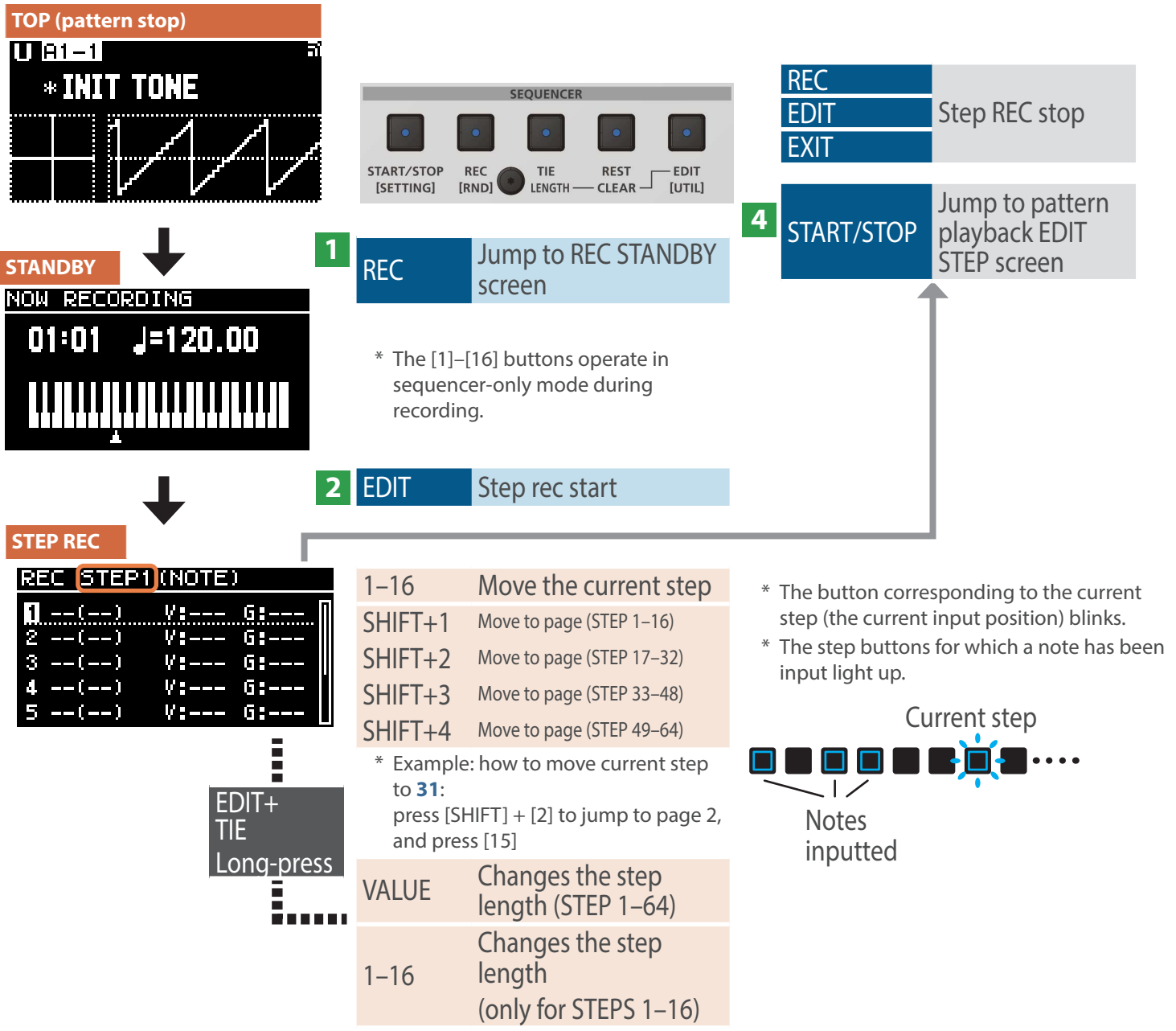

You can freely edit the patterns later that you've recorded.

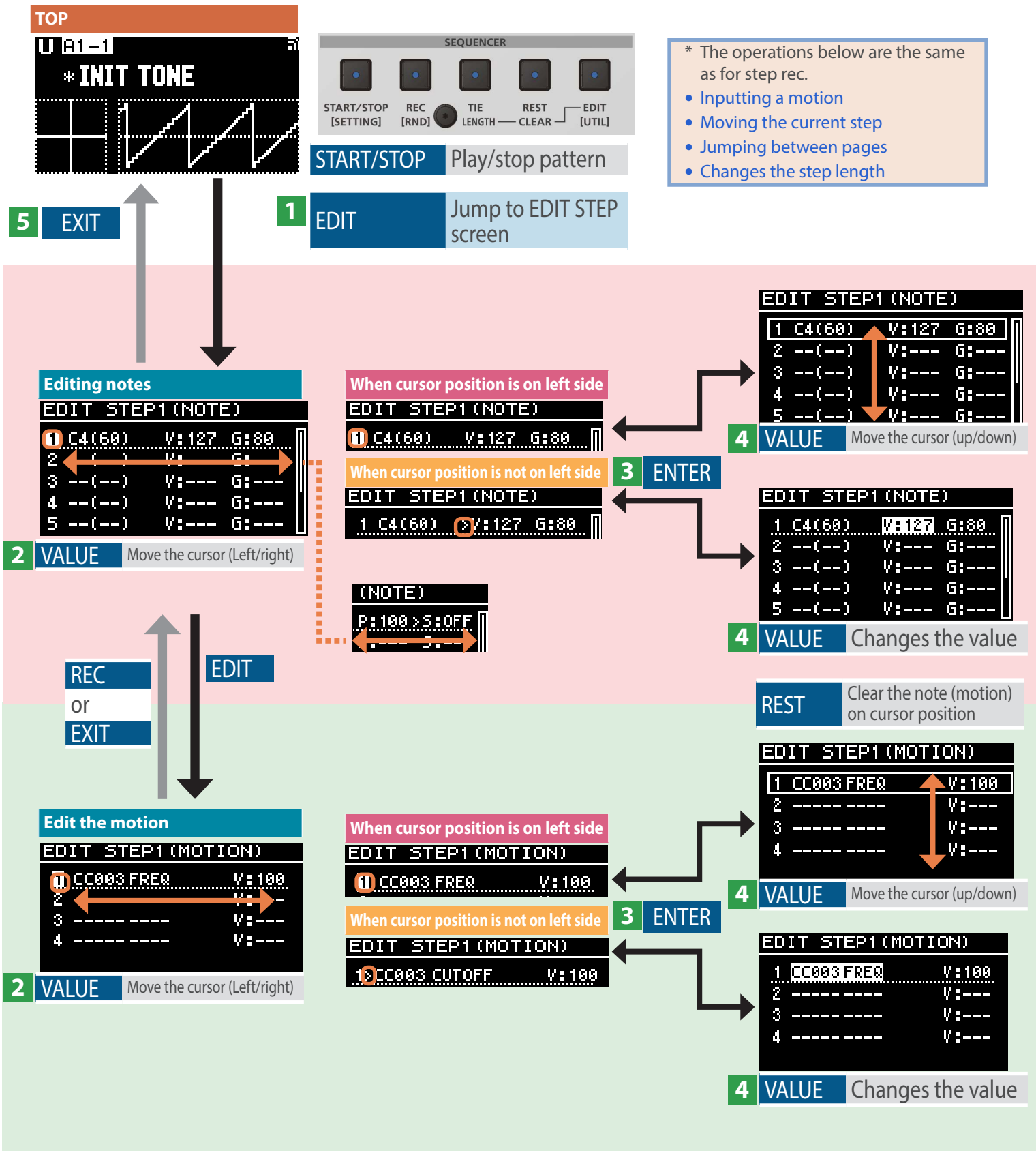

Data that can be inputted/edited

EDIT STEP1 (NOTE)				EDIT STEP1 (MOTION)		
1	C4(60)	V:127	G:80	1	CC003 FREQ	V:100
			P:100 > S:OFF			

Note No. Velocity Gate Probability Sub Steps CC No. Parameter Value

Here's how to erase notes or motions from a pattern you've recorded.

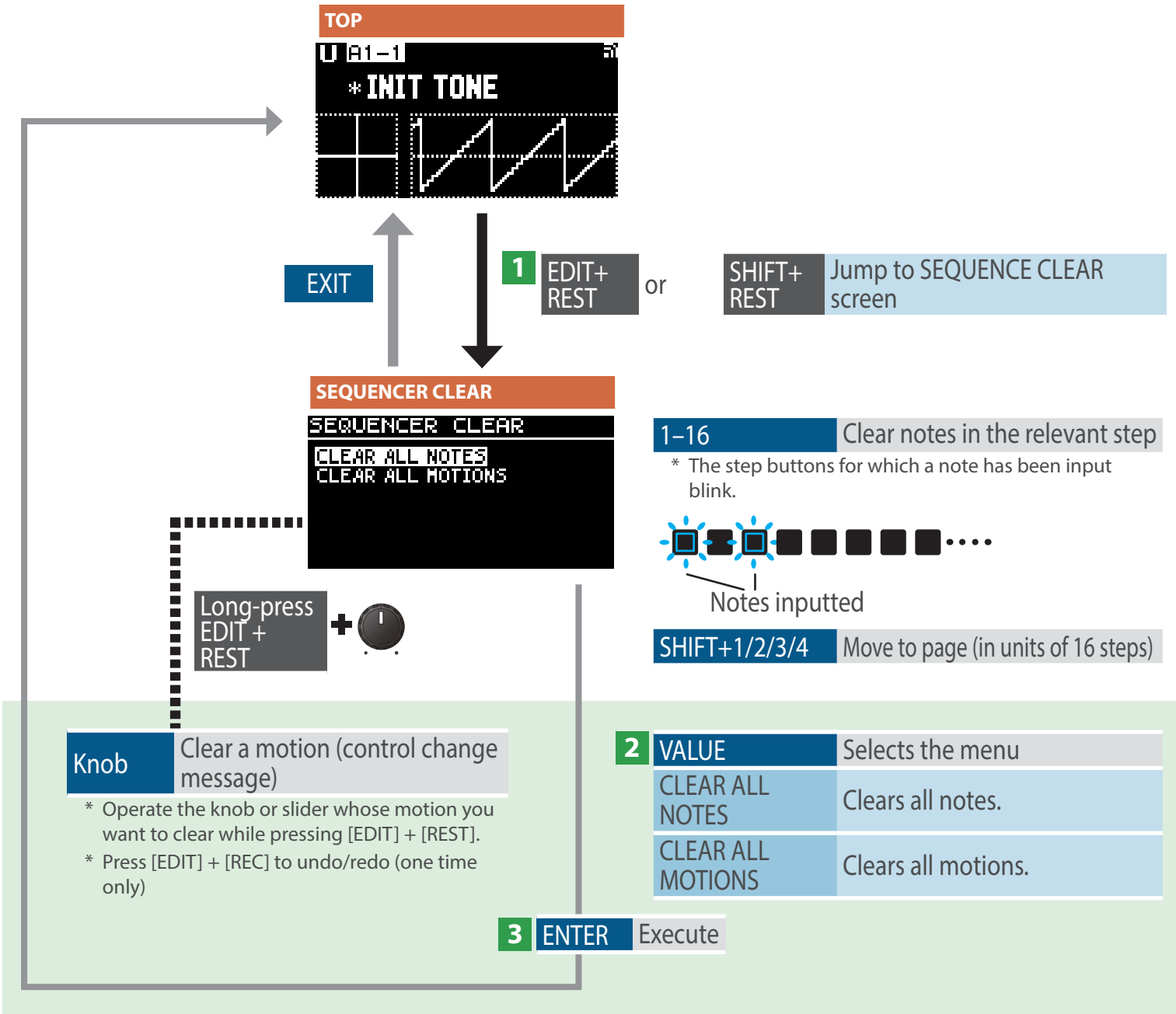

Here's where you configure the settings for recorded patterns.

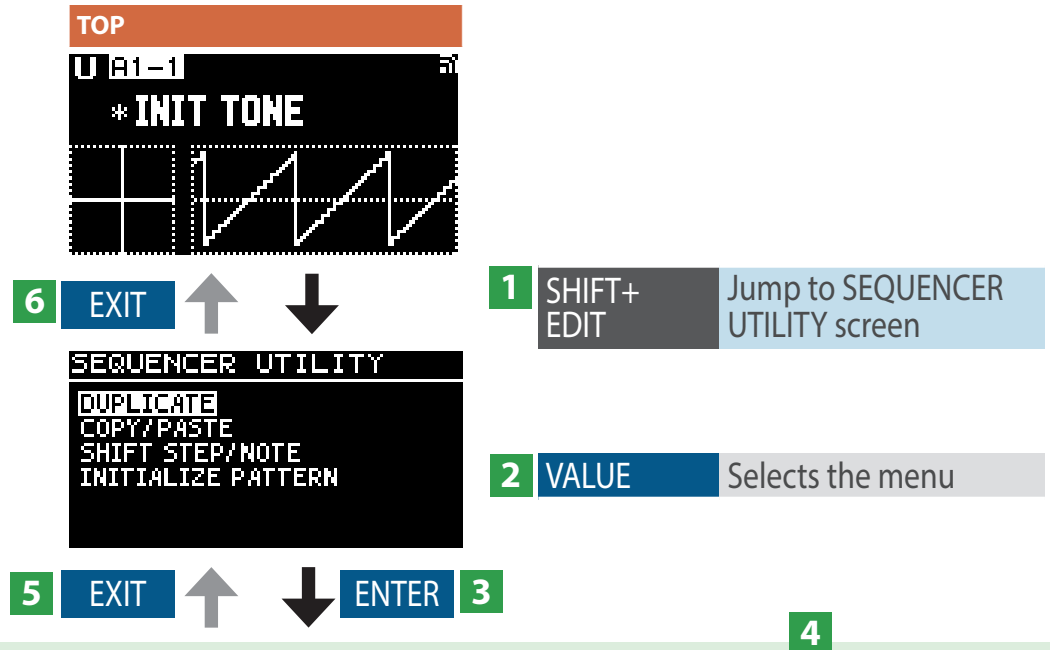

DUPLICATE

Copies (duplicates) the entire pattern (notes and motions) to the end.

* This is disabled when Step Length is set to 64 (maximum setting).

COPY/PASTE

Copies the entire pattern or the contents of a specific step and pastes this to a different pattern or step.

SHIFT STEP/NOTE

Shifts the step position or note numbers of the entire pattern backward/forward (up/down).

INITIALIZE PATTERN

Initializes an entire pattern. The SEQUENCER SETTING parameters are also initialized.

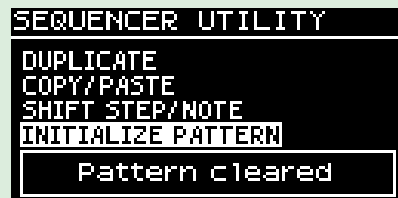
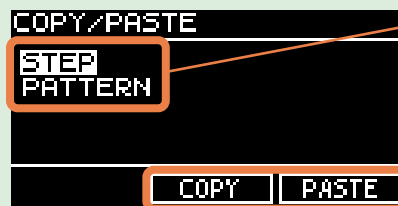
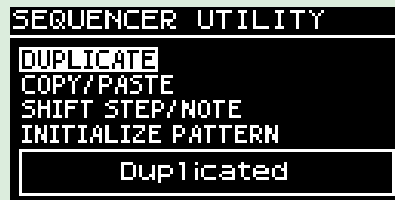

ENTER Execute

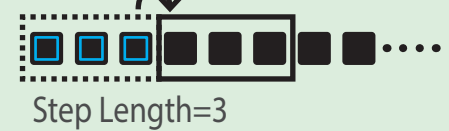

VALUE Select STEP or PATTERN

ENTER Confirm

VALUE Select COPY or PASTE

ENTER Execute

EDIT common operations (cursor/ value edit)

Edits the setting

VALUE Selects SET

ENTER Execute

ENTER Execute

Sequencer utility settings

Parameter	Value	Explanation
COPY/PASTE		
---	STEP	Sets the contents of a single step as the target.
	PATTERN	Sets the entire contents of the pattern as the target.
---	COPY	Copies a single step or the entire pattern. For step copy, the content is copied at the current step position (specified using the [1]–[16] buttons).
	PASTE	Pastes a single step you copied, or the entire pattern. For step paste, the content is pasted at the current step position (specified using the [1]–[16] buttons). You can also paste the contents you copied into a separate pattern.
SHIFT STEP/NOTE		
Step	-16–+16	A positive value shifts the step position to the right, and a negative value shifts the step position to the left.
Transpose	-24–+24	A positive value shifts the pitch up, and a negative value shifts the pitch down (both in semitones).

Edit step settings

```
EDIT STEP1 (NOTE)
1 C4(G0) >V:127 G:80 P:100 >S:OFF
```

```
EDIT STEP1 (MOTION)
1 CC003 FREQ V:100
```

Note No. Velocity Gate Probability Sub Steps CC No. Parameter Value

Parameter	Value	Explanation
EDIT STEP		
Note No.	C-1–G9	Note number
Velocity	0–127	Sets the strength with which the notes sound that you play on the keyboard.
Gate	0–100, TIE	Sets the note-on length ratio for the step. TIE: The notes of the current step are connected to the notes of the next step with a tie.
Probability	0–100	Sets the probability for the step to sound.
Sub Steps	OFF, FLAM, 1/4, 1/3, 1/2	Sets the manner in which sounds play repeatedly within a step. <div style="text-align: center;"> <p>OFF: [] [] [] [] FLAM: [] [] [] [] 1/4: [] [] [] [] 1/3: [] [] [] [] 1/2: [] [] [] []</p> </div>
CC No.	CC001–CC119, BEND	Control change number
Parameter	—	Parameter name
Value	0–127 (255)	Value

Here's where you configure the overall settings for this instrument.

- The system settings are saved internally as a single collection. The settings are saved automatically when you return to the menu screen.
- Do not turn off the power when "Now Writing..." is shown on the screen.

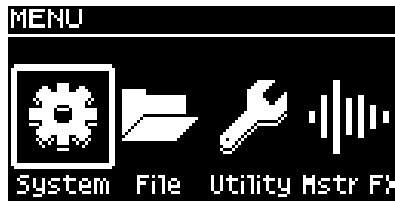

2 VALUE Select System

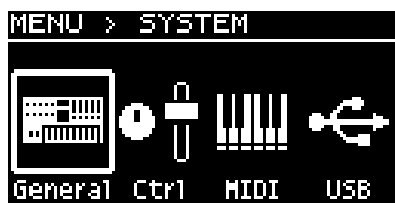

4 VALUE Selects the menu

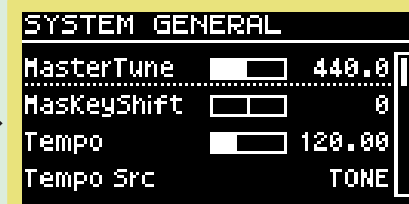

GENERAL

Configures various settings such as tuning and output level.

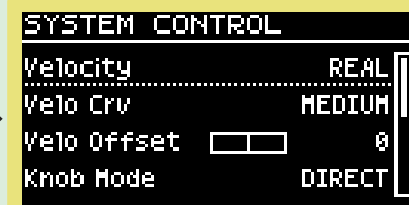

CONTROLLER

Configures the settings for the controllers and so on.



MIDI

Configures the MIDI settings.



USB

Configures the USB settings.

This configures the common master effect settings for the overall instrument.

- The master effect settings are saved internally as a single collection. The settings are saved automatically when you return to the menu screen.
- Do not turn off the power when “Now Writing...” is shown on the screen.

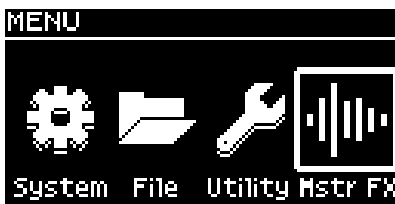

2 VALUE Select Mstr FX

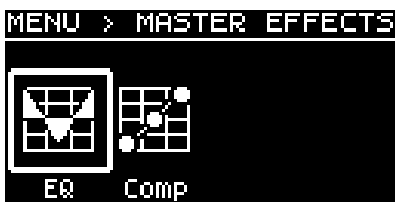

4 VALUE Select EQ or Comp



MASTER EQ

Configures the master EQ settings.

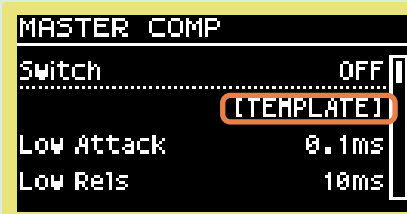

MASTER COMP

Configures the master compressor settings.

VALUE Select [TEMPLATE]
ENTER TEMPLATE screen

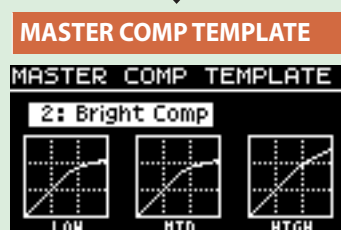

VALUE Selects a template
EXIT Cancel
ENTER Confirm

Backup

Here's how to back up data stored on this instrument to a USB flash drive.

Data that is backed up

- User tone data
- System settings
- * The backup file (.SVD) is saved to the following location: USB Memory\ROLAND\GAIA-2\BACKUP.

USB MEMORY/EXT DEVICE port

1 EXIT ↑ ↓ MENU

2 VALUE Select "File"

3 EXIT ↑ ↓ ENTER

4 VALUE Select "Backup"

5 EXIT ↑ ↓ ENTER

	ENTER	
Cursor mode	↔	Character select mode
Move the cursor	VALUE	Change the character
↻: insert	SHIFT+VALUE	↻: uppercase
↻: delete		↻: lowercase
6 Select "OK"	VALUE	

7 EXIT ↑ ↓ ENTER

8 VALUE Select "OK"

9 ENTER Execute

BACKUP
Are you sure?
CANCEL OK

Here's how to restore data that you backed up on a USB flash drive to this instrument.

* All user data is overwritten when you execute the restore operation. If you've saved important data on this instrument, assign it a different name and back it up to a USB flash drive before you restore.

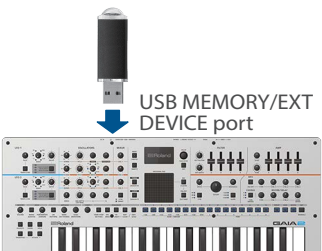

1 **EXIT** ↑ ↓ **MENU**

2 **VALUE** Select "File"



3 **EXIT** ↑ ↓ **ENTER**

4 **VALUE** Select "Rstr"

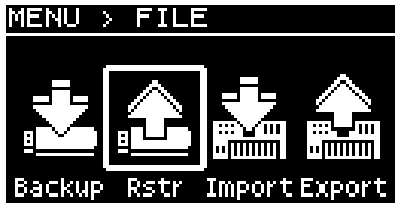

5 **EXIT** ↑ ↓ **ENTER**

6 **VALUE** Select file to restore

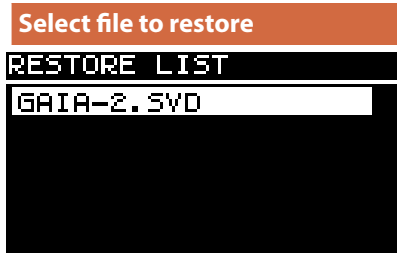

7 **EXIT** ↑ ↓ **ENTER**

8 **VALUE** Select "OK"

9 **ENTER** Execute



* Once "Completed" appears, turn the power off and then on again.

Here's how to export selected user tone data to a USB flash drive.

* You can't use the user tone data of the GAIA-2 with any other model.

* The export file (.SVZ) is saved to the following location: USB Memory\ROLAND\SOUND.

1 EXIT ↑ ↓ MENU

2 VALUE Select "File"

3 EXIT ↑ ↓ ENTER

4 VALUE Select "Export"

5 EXIT ↑ ↓ ENTER

6 VALUE Select a tone

7 MENU Mark the tones to export

MENU+VALUE Select tone while marking

MENU+ENTER Mark all tones

8 EXIT ↑ ↓ ENTER

9 VALUE Select "OK"

Cursor mode	← →	Character select mode
Move the cursor	VALUE	Change the character
↻: insert	SHIFT+VALUE	↻: uppercase
↻: delete		↻: lowercase

10 EXIT ↑ ↓ ENTER

11 VALUE Select "OK"

12 ENTER Execute

Export Tone
Are you sure?
CANCEL OK

Here's how to import the tones you exported into user tones.

- * Save the file you wish to import (.SVZ or .SDZ) to the following location: USB Memory\ROLAND\SOUND.
- * If a Model Expansion is installed, you can also import tones for that model (Model Expansion Sound Packs) that you downloaded from Roland Cloud.

1 EXIT ↑ ↓ MENU

2 VALUE Select "File"

3 EXIT ↑ ↓ ENTER

4 VALUE Select "Import"

5 EXIT ↑ ↓ ENTER

6 VALUE Select the file to import

7 EXIT ↑ ↓ ENTER

8 VALUE Select a tone
MENU Mark the tones you want to import

9 ENTER

10 VALUE Select a tone
MENU Mark the import destination tones

11 ENTER

12 VALUE Select "OK"
ENTER Execute

* For the import destination tones, tones named "INIT TONE" are given priority when selected. Be sure to check whether any tones you don't want to be overwritten are excluded before importing.

Common to **8** and **10**

- MENU+ VALUE Select tone while marking
- MENU+ ENTER Mark all tones



Here's how the settings that you edited and saved on the GAIA-2 can be returned to their factory settings.

- * When you execute this operation, all saved settings including the sound parameters will be lost.
- * If you will later need the current settings, be sure to use the backup function to save the current settings before you restore the factory settings. → "Backup"

Add a check mark to the items to reset.

Reset User Data	Resets the user data.
Reset System Date	Resets the system data.
Remove License	Resets the license.

Here's how to format a USB flash drive.

- * If the USB flash drive contains important data, be aware that this operation erases all data from the drive.

- * When "Remove License" is executed, the registered data on Roland Cloud is deleted, and you cannot use any contents you've purchased, such as Model Expansions. To use the contents again, refer to the "GAIA-2 Roland Cloud User's Guide" (Roland website) and register your license. Note that in case you accidentally executed the "Remove License" command, the data for the contents you purchased is still available. Register the same license to use the contents again.

* Once "Completed" appears, turn the power off and then on again.

You can view software version of the GAIA-2.

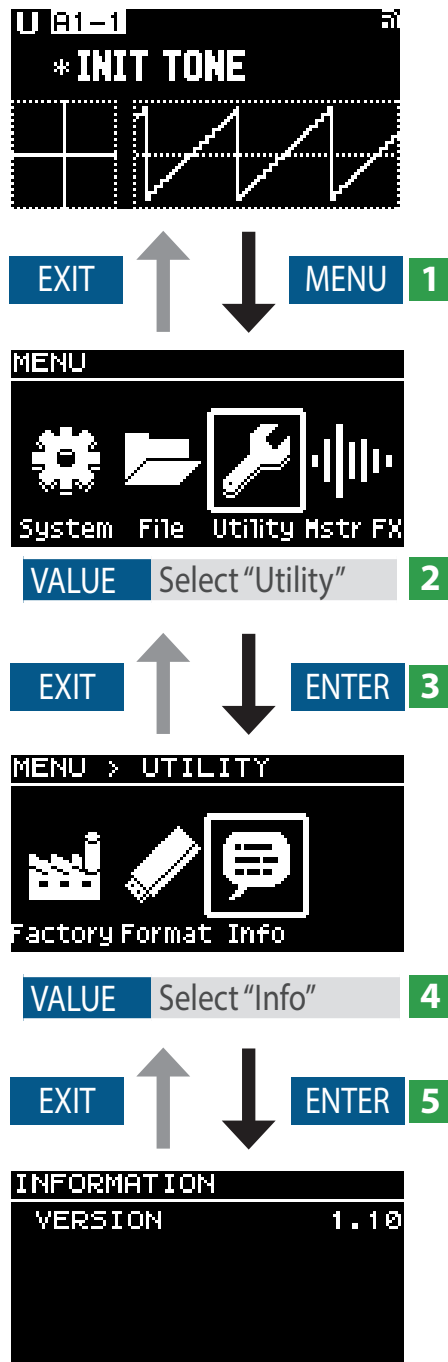

Overview of the GAIA-2

How the tones are organized

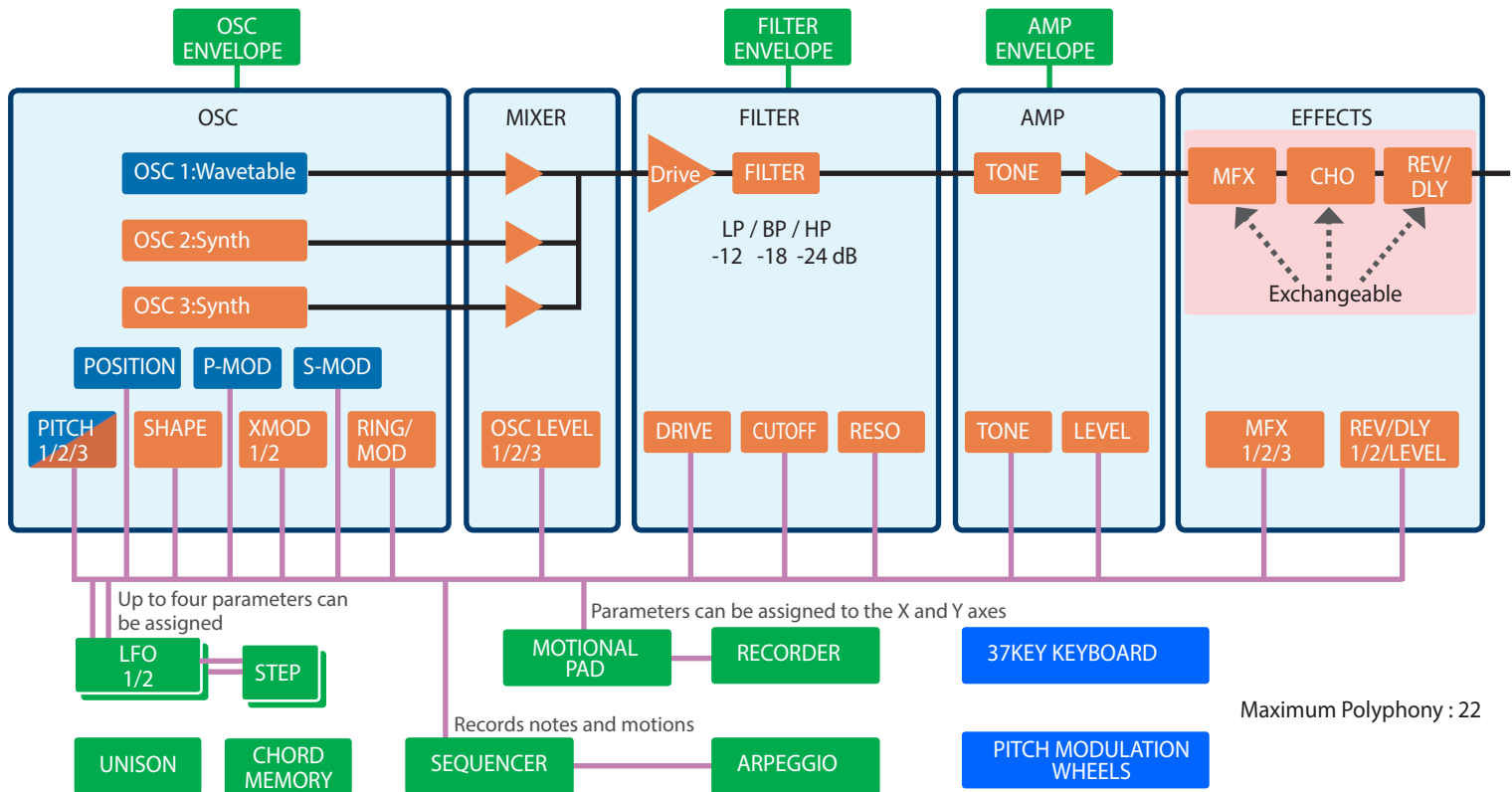

Audio routing

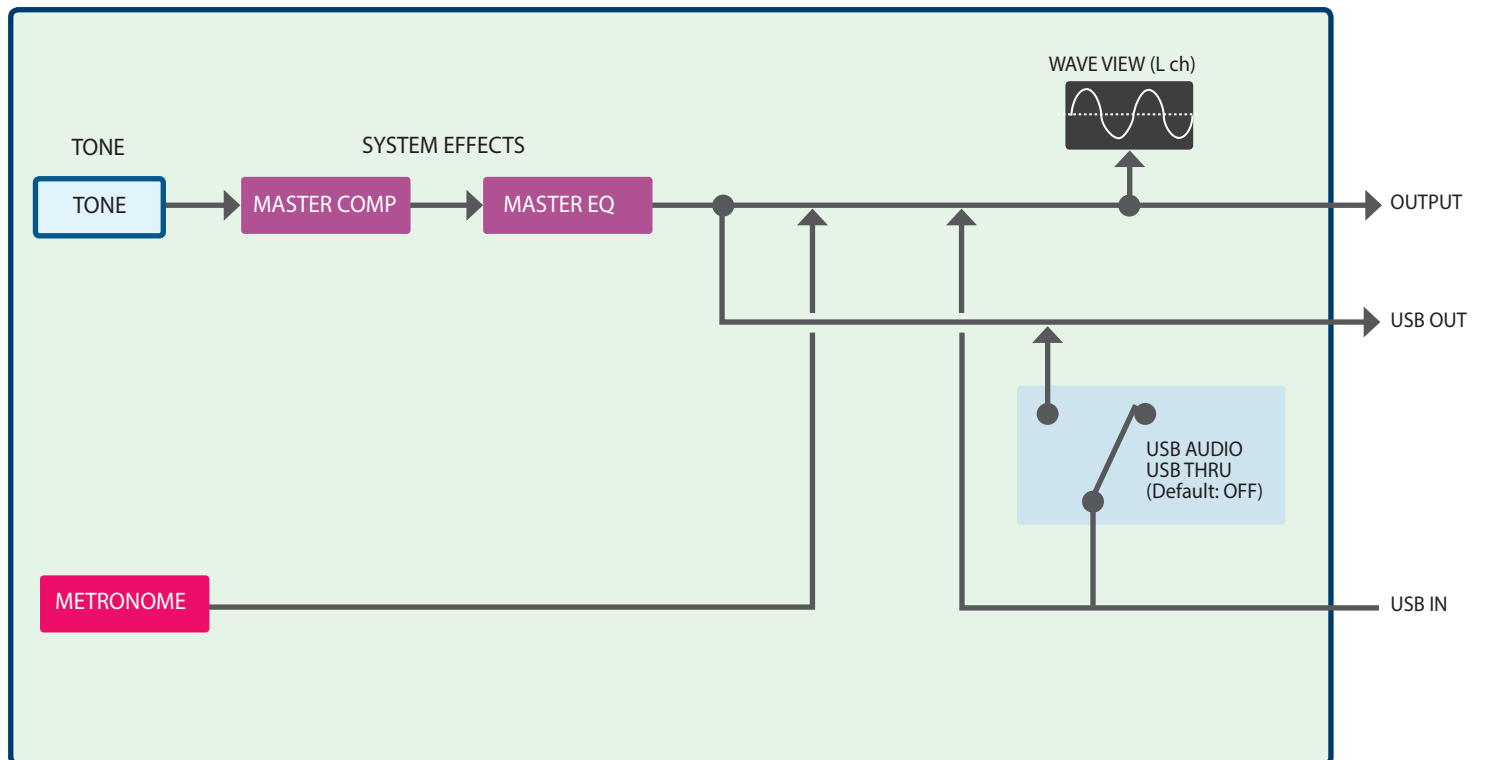

* To prevent malfunction and equipment failure, always turn down the volume, and turn off all the units before making any connections.

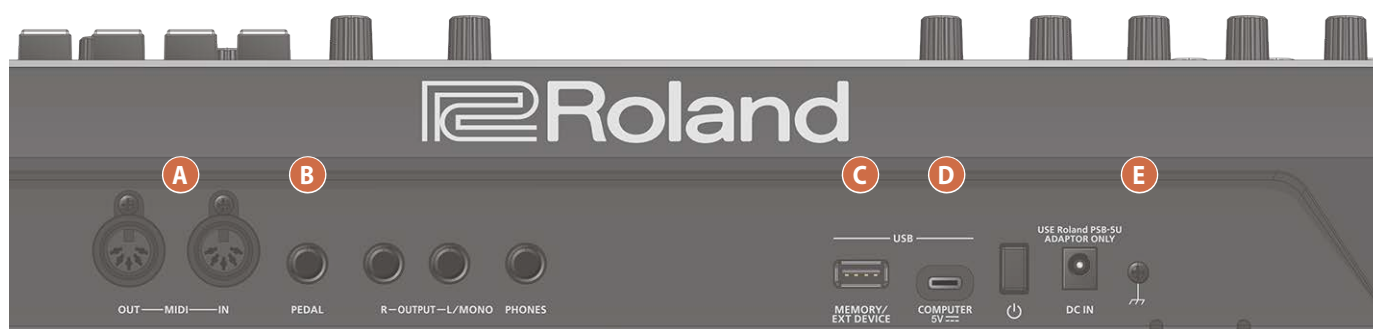

A MIDI IN, MIDI OUT connectors

You can connect a MIDI device to this connector.

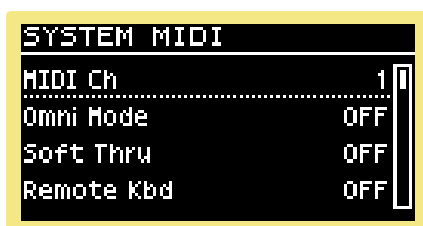

B PEDAL jack

You can connect an expression pedal (EV-5, sold separately) or pedal switch (DP series, sold separately) to this jack.

* Be sure to use only one of these specified pedals. Connecting expression pedals made by third-party manufacturers may cause this unit to malfunction.

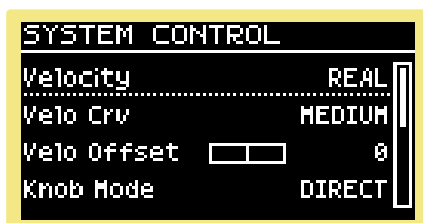

C USB MEMORY/EXT DEVICE port (USB A)

Connect a commercially available USB flash drive, external USB device or Roland Cloud Connect (WC-1) here.

* Never turn off the power or unplug the USB flash drive while "○○%" is shown in the display, which indicates that the a write operation is in progress.

D USB COMPUTER port (USB Type-C®)

Connect the USB port of your computer or mobile device to this port.

* Do not use a USB cable that is designed only for charging. Charge-only cables cannot transmit data.

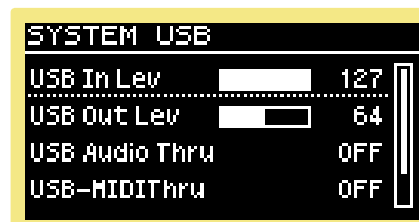

E Ground terminal

Connect this to an external earth or ground if necessary.

- You can connect a USB flash drive to the instrument for exchanging data, creating a backup and so on.
- You can also connect a MIDI keyboard or other external MIDI controller for use with this instrument.
- Further, you can connect a Roland Cloud Connect (WC-1) to access and use your Roland Cloud contents via Wi-Fi.

Connecting a USB flash drive

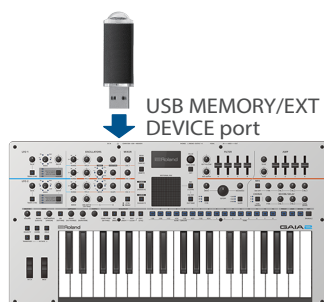

Connecting the Roland Cloud Connect (WC-1)

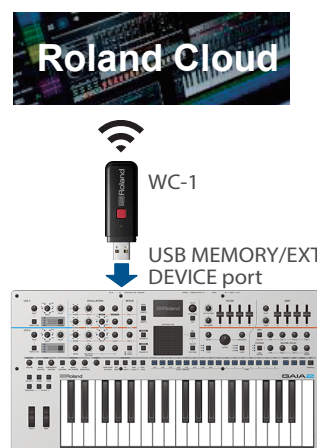

- * For more details, see the related manuals on the Roland website.
<https://roland.cm/wc1>

Connecting to a MIDI controller



- * You can power a MIDI controller from the GAIA-2, provided that the MIDI controller's power consumption is 500 mA or less.
- * Configure the GAIA-2 system parameters when using a MIDI controller. When connecting a general external MIDI keyboard, set the "Remote Kbd" SYSTEM MIDI parameter to "USB MEM".

- You can connect this instrument to a computer (Windows/Mac) for music production with your DAW or other software.
- This instrument is USB Class Compliant, and can be connected directly to your smartphone or tablet via audio or MIDI data transmission.
 - * Do not use a USB cable that is designed only for charging. Charge-only cables cannot transmit data.
 - * We cannot guarantee the correct functionality of all apps.
 - * Android devices are not guaranteed to work with this instrument.
- This instrument is AIRA LINK-compatible, and can be connected to a Roland MX-1 via USB cable (When doing so, set the USB driver to "VENDOR").
 - * You cannot use the USB power supply functionality of the MX-1 with the GAIA-2.
- You can connect the GAIA-2 to a computer, USB AC adaptor or other power supply of 1.8 A or greater to power this instrument.
 - * To power this instrument, connect using a USB cable (with USB Type-C® connectors on both ends). Although this instrument can be connected to a computer via USB cable (USB Type-C® - USB Type-A), you cannot power this instrument in this way.

Connecting to a Mac/Windows computer

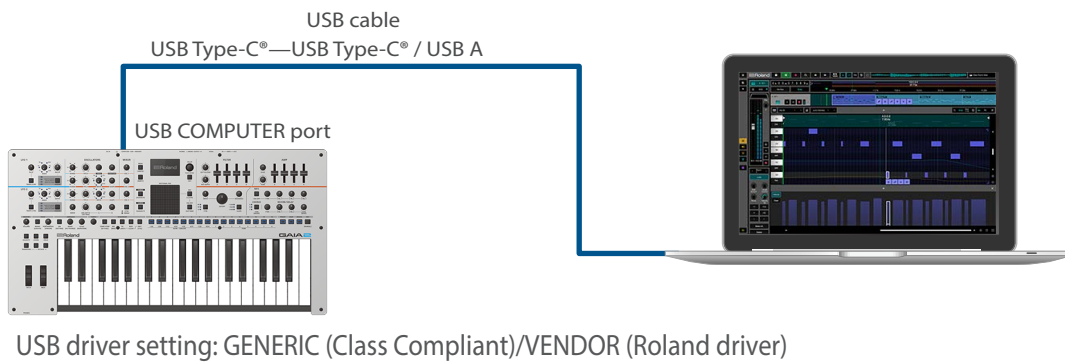

Connecting to an iPhone/iPad

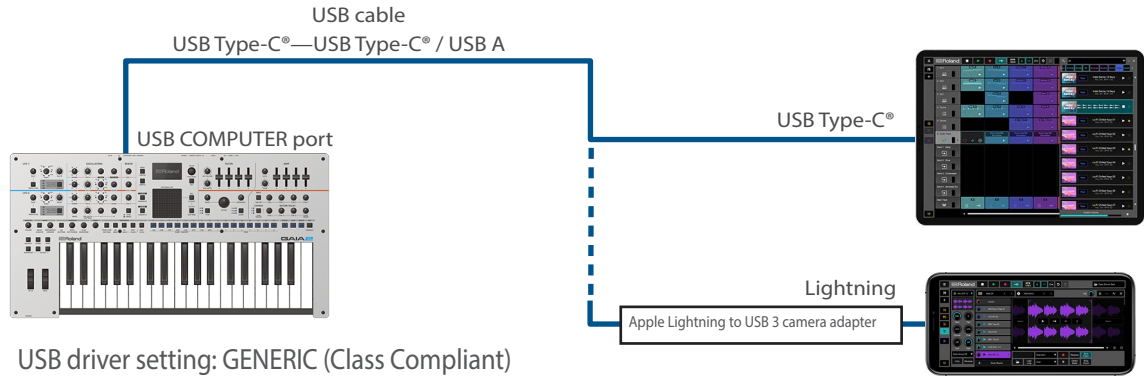

- * We have confirmed that noise may occur when connecting certain Apple products featuring a Lightning connector using Apple's Lightning to USB Camera Adapter. This may be resolved by using the Lightning to USB 3 Camera Adapter instead. For more details and for the latest support information, see "GAIA-2 Support Information".
- * See the product information released by Apple for the differences between the Lightning to USB Camera Adapter and the Lightning to USB 3 Camera Adapter.

Using AIRA LINK

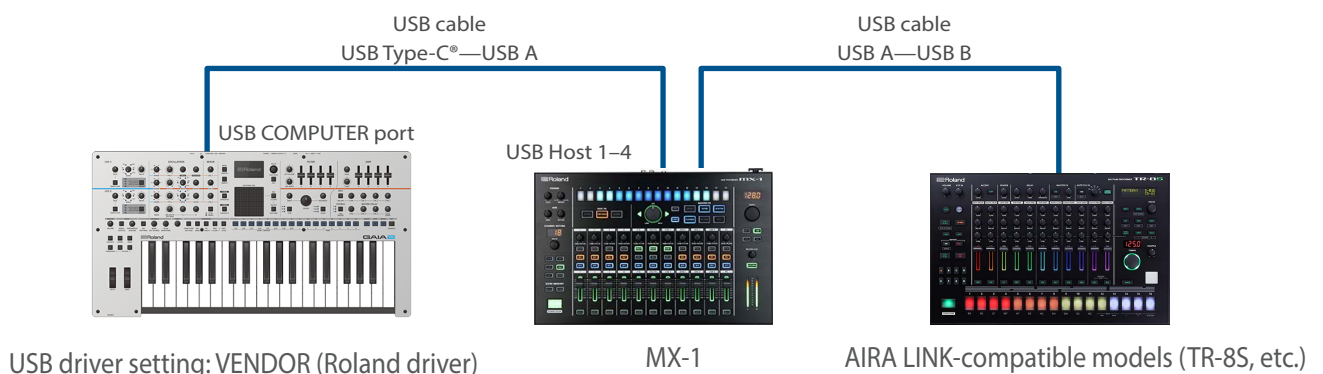

Cell color	Explanation
Blue	Parameters that can be directly operated from the panel.
Green	Parameters that can be directly operated from the panel (while the SHIFT button is pressed).
Orange	Standard parameters that can be edited from the SOUND screen.

MOTION

Parameter	Value	Explanation
MOTION SETTING		
Motion	OFF, ON	Turn this "ON" to play back the motion.
Speed	-10.0, -9.5, -0.02, 0, +0.02, +9.5, +10.0	Selects the playback speed of the motion (tempo, or value relative to one measure).
X	– (*1)	Assigned parameter for X displacement
Y	– (*1)	Assigned parameter for Y displacement
X Depth	-63–+63	Parameter sensitivity relative to X displacement (same as LFO Depth)
Y Depth	-63–+63	Parameter sensitivity relative to Y displacement (same as LFO Depth)
Loop	OFF, ON	Loop playback on/off
Key Trig	OFF, ON	When set to "ON", the motion starts playing back when you play a key.
Sync	OFF, ON	Tempo Sync on/off. When set to "ON", the playback length of one loop at Speed +1.0 is equal to a whole note.
Snap Back		Sets whether to return the pad to center position when you take your hand off the pad.
	OFF	Retains the position even after you take your hand off the pad.
	SLUG	Returns to center position extremely slowly after you take your hand off the pad.
	SLOW	Returns to center position slowly after you take your hand off the pad.
	MID	Returns to center position at regular speed after you take your hand off the pad.
	FAST	Returns to center position quickly after you take your hand off the pad.
	IMMD	Returns to center position immediately after you take your hand off the pad.

*1 Refer to this list for the assignable parameters. → "Panel parameter assignment list"

ARPEGGIO

Parameter	Value	Explanation
ARPEGGIO SETTING		
Arp Sw	OFF, ON	Turns the arpeggio on/off.
Duration	0–100%	Sets the length (ratio) used for playing back each note length in the arpeggio pattern.
Shuffle Rate	0–100%	Creates a shuffle rhythm by varying the timing at which the upbeat notes play. When this setting is “50%”, notes are sounded at equal spacing. Increasing the value adds a shuffle feel like a dotted-note rhythm.
Oct Range	-3–+3	Specifies the range of octaves in which the arpeggio is sounded. You can specify whether the arpeggio is sounded in the octave(s) above (+) or below (-) the notes you play.
Transpose	-36–+36	Shifts the arpeggio notes in semitone steps.
Mode	Sets the order in which notes are played by the arpeggio when you play a chord.	
	UP	The notes are played from the lowest key you played to the highest.
	DOWN	The notes are played from the highest key you played to the lowest.
	UP&DOWN	The notes are played from low to high, and then from high to low.
	RANDOM	The notes are played in random order.
	NOTE ORDER	The notes are played in the order in which you play them.
Shuffle Reso	16TH, 8TH	This sets the note value that the shuffle is based on. 16TH: sixteenth note 8TH: eighth note
Scale	1/1, 1/2, 1/4, 1/8, 1/16, 1/32, 1/2T, 1/4T, 1/8T, 1/16T, 1/2., 1/4., 1/8., 1/16.	Sets the length of a single note in the arpeggio pattern. 1/16: sixteenth note 1/16T: sixteenth note triplets 1/16.: Dotted sixteenth note
Velocity	REAL, 1–127	Sets the velocity of notes played by the arpeggiator. To make the arpeggio play at the strength (velocity) with which you play the keys, set this to “REAL”. If you want the velocity to be a fixed value regardless of your actual playing dynamics, specify that value (1–127).

SEQUENCER

Sequencer settings

Parameter	Value	Explanation
SEQUENCER SETTING		
Step Length	1–64	Sets the length (number of steps) of the pattern.
Scale	1/1, 1/2, 1/4, 1/8, 1/16, 1/32, 1/1T, 1/2T, 1/4T, 1/8T, 1/16T	Sets the length of each step in the pattern. 1/16: sixteenth note 1/16T: sixteenth note triplets
Mode	Sets the step playback order when the pattern plays back.	
	FWD	The steps play back in order from step 1.
	REV	The steps play back in order from the last step.
	FWD+REV	The steps are played in order from step 1, and then in reverse from high to low.
	INV	The even- and odd-numbered steps are inverted when played.
	RND	The steps are played in random order.
KEY_TRIG	The notes play back from step 1 in order, but only while a key is being played.	
Gate Ratio	-128–+127	Specifies the gate length. This is common for all steps.
Shuffle	-90–+90	Sets the timing at which the even-numbered steps play.
Motion	OFF, ON	Turns the motion (control change message) playback on/off.
Smooth	OFF, ON	When this is on, the motion plays back smoothly.
Play/Trans	OFF, ON	OFF: The pattern plays back as-is. ON: The pattern plays back transposed according to the key you press.

Random pattern settings

Parameter	Value	Explanation
RANDOM PATTERN		
Key	C2(36)–C7(96)	Sets the base pitch for generating the pattern.
Scale	Sets the scale of pitches used for generating the pattern. IONIAN, DORIAN, PHRYGIAN, LYDIAN, MIXOLYDIAN, AEOLIAN, LOCRIAN	
Balance	Sets the ratio at which the notes out of the scale notes specified in Scale are used in the generated pattern.	
	CHORD	Only chord tone notes are used in the pattern.
	MIX1	Any notes within the scale are used in the pattern.
	MIX2	As the balance approaches MIX1→MIX2→ALL, more tones are likely to be used that are not chord tones.
ALL		
Octave	1–4	Specifies the note range for the generated pattern, in octaves.
Velocity Lo	1–126	Sets the lower limit for the velocity variations within the generated pattern.
Velocity Hi	2–127	Sets the upper limit for the velocity variations within the generated pattern.
Gate Amount	1–16	Sets the gate time length for the notes of the generated pattern.
Busyness	10–100%	Sets the frequency (likelihood of occurrence) at which notes are generated within the pattern.
Length	1–64	Sets the length (number of steps) of the generated pattern.

TONE parameters

TONE

GAIA-2

Parameter	Value	Explanation
OSC1		
Range	64', 32', 16', 8', 4', 2'	Adjusts the octave of the oscillator.
Pitch	-1200-0-+1200 (cent)	Adjusts the pitch of the oscillator. * The pitch may not reach the value that you set, depending on the sound parameter settings.
Wavetable Position	0-127	Adjusts the wavetable position.
S-Mod Table Number	1-15	<p>Selects the shaping modulation table.</p>
P-Mod Limiter Sw	OFF, ON	When set to "ON", this limits the depth of the phase modulation X direction.
Wave	1-63	Selects the wavetable.
P-Mod X	-63-0-+63	Adjusts the depth of the phase modulation X direction.
P-Mod Y	-63-0-+63	Adjusts the depth of the phase modulation Y direction.
S-Mod Depth	0-127	Adjusts the intensity of the shaping depth for shaping modulation.
S-Mod Drive	0-127	Adjusts how much drive is applied to the shaping modulation.
OSC2 / OSC3		
Range	64', 32', 16', 8', 4', 2'	Adjusts the octave of the oscillator.
Pitch	-1200-0-+1200 (cent)	Adjusts the pitch of the oscillator. * The pitch may not reach the value that you set, depending on the sound parameter settings.
Waveform	Selects the oscillator waveform.	
	SIN	Sine wave
	TRI	Triangle wave
	SAW	Sawtooth wave
	PULSE	Pulse wave
	SUPER-SAW	Super-Saw
Sine Shape Select	PW, FAT	Sets what happens when you operate a sine wave shape. PW: Alters the waveform width. FAT: Emphasizes the lower frequencies.
		Triangle Shape Select

Parameter	Value	Explanation
Saw Shape Select	PW, FAT	Sets what happens when you operate a sawtooth wave shape. PW: Alters the pulse width. FAT: Emphasizes the lower frequencies.
Pulse Shape Select	PW, FAT	Sets what happens when you operate a pulse wave shape. PW: Alters the pulse width. FAT: Emphasizes the lower frequencies.
Noise Vari	Sets the combination of noise that changes when you operate a noise shape. White-Pink, Pink-Appraise, Stream-Bubble, VinINz-EngineLp, MtlWind-DentNz	
Shape	0–255	Adjusts the changes to the waveform shape. Detune changes when you select the SUPER-SAW.
Click Type	SOFT, HARD, NATURAL, OFF	Changes the attack by altering the start position of the sound.
COMMON		
Tempo	20.00–300.00	Sets the tempo of the tone (including the arpeggio, motion and sequencer).
Level	0–127	Adjusts the overall volume for all tones.
Pan	L64–0–63R	Sets the panning for the tone. A setting of “L64” pans the sound all the way to the left, “0” pans the sound to the center, and “63R” pans the sound all the way to the right.
Mono/Poly	Sets whether the tones play in polyphonic (POLY) or monophonic (MONO) mode.	
	MONO	Only one sound at a time plays, and only the last key you played produces sound.
	POLY	More than one sound can play at the same time.
Legato Switch	OFF, ON	When Mono/Poly is “MONO” and Legato Switch is “ON”, legato is applied to the notes. “Legato” is a performance technique that smoothly connects one note to the next. This produces an effect similar to hammering-on or pulling-off when playing a guitar.
Portamento Time	0–255	When portamento is used, this sets the time taken for the pitch to change. Higher settings cause the pitch to take longer when gliding to the next note. A value of “0” turns the portamento “OFF”.
Unison Switch	OFF, ON	This layers a single sound. If the Unison Switch is “ON”, the number of notes layered on one key will change according to the number of keys you play.
Unison Detune	0–63	Creates a detuned effect by shifting the tuning of the layered notes. Larger values detune the sounds more, making the overall sound thicker.
Unison Spread	0–63	Spreads out the layered sounds over the stereo field. Larger values increase the spread effect.
Chord Switch	OFF, ON	Turns the chord memory function on/off.
Hold Switch	OFF, ON	While this is “ON”, the notes you play keep sounding even after you take your fingers off the keyboard.
Category	Selects the tone category.	
	No Assign–Vocoder (*) The GAIA-2 does not have a built-in vocoder.	
MIXER		
OSC1 Level	0–127	Adjusts the OSC1 volume.
OSC2 Level	0–127	Adjusts the OSC2 volume.
OSC3 Level	0–127	Adjusts the OSC3 volume.

Parameter	Value	Explanation
OSC MODULATION		
Ring/Sync	Sets how the modulation that applies to OSC2 and OSC3 works.	
	OFF	Nothing is applied.
	RING	Ring modulation is applied.
	SYNC	OSC sync is applied.
XMOD Type	XMOD1, XMOD2	Selects the cross-modulation type.
XMOD1 Depth	0–255	Adjusts the depth of XMOD1.
XMOD2 Depth	0–127	Adjusts the depth of XMOD2.
XMOD2 Sens	-63–0–+63	Adjusts the OSC envelope depth.
XMOD2 Velocity Sens	-100–0–+100	Adjusts the intensity of XMOD2 Depth, according to how hard you play the keys.

* The following limitations exist for the Sync and XMOD2 effect, according to the waveform you select for OSC2, 3.

Sync		OSC3					
		SIN	TRI	SAW	PULSE	S-SAW	NOISE
OSC2	SIN	✓	✓	✓	✓	—	—
	TRI	✓	✓	✓	✓	—	—
	SAW	✓	✓	✓	✓	—	—
	PULSE	✓	✓	✓	✓	—	—
	SUPER-SAW	—	—	—	—	—	—
	NOISE	—	—	—	—	—	—

XMOD2		OSC3					
		SIN	TRI	SAW	PULSE	S-SAW	NOISE
OSC2	SIN	✓	✓	✓	✓	✓	✓
	TRI	✓	✓	✓	✓	✓	✓
	SAW	✓	✓	✓	✓	✓	✓
	PULSE	✓	✓	✓	✓	✓	✓
	SUPER-SAW	—	—	—	—	—	—
	NOISE	—	—	—	—	—	—



OSC ENVELOPE

OSC Env Sel	This selects the parameter that's applied to the OSC envelope. PITCH, OSC1 POS, OSC2 SHAPE, OSC3 SHAPE, OSC1 P-MOD X, OSC1 P-MOD Y, OSC1 S-MOD DPT, OSC1 S-MOD DRV	
O-Env Attack Time	0–255	Adjusts the time it takes for the value set in Env depth to be reached after you press a key.
O-Env Decay Time	0–255	Adjusts the time it takes to return to the initial value from the value set in Env depth.
OSC1 Pitch Env Enable	OFF, ON	Sets whether to apply the pitch envelope (ON) or not (OFF) to OSC1.
Pitch Env Depth	-100–0–+100	When you turn the knob clockwise, the pitch goes up and then returns to the pitch of the key you press. When you turn the knob counterclockwise, the pitch goes down and then returns to the pitch of the key you press. * The effective pitch env depth range for OSC1 is -63–+63. * The pitch may not reach the value that you set, depending on the sound parameter settings.
Pitch Env V-Sens	-100–0–+100	Adjusts how much the pitch envelope is applied in response to how hard you play the keys.
OSC1 WT Pos Env Depth	-63–0–+63	Adjusts the depth of change to wavetable position by the OSC envelope.
OSC2 Shape Env Depth	-63–0–+63	Adjusts the depth of change to OSC2 shape by the OSC envelope.
OSC3 Shape Env Depth	-63–0–+63	Adjusts the depth of change to OSC3 shape by the OSC envelope.
OSC1 P-Mod X Env Depth	-63–0–+63	Adjusts the depth of change to phase modulation X by the OSC envelope.

Parameter	Value	Explanation
OSC1 P-Mod Y Env Depth	-63-0-+63	Adjusts the depth of change to phase modulation Y by the OSC envelope.
OSC1 S-Mod Dpt Env Dpt	-63-0-+63	Adjusts the depth of change to shaping modulation depth by the OSC envelope.
OSC1 S-Mod Drv Env Dpt	-63-0-+63	Adjusts the depth of change to shaping modulation drive by the OSC envelope.

LFO 1 / LFO 2

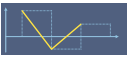
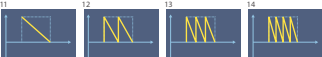
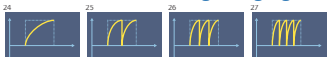
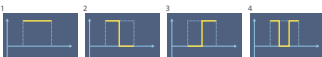
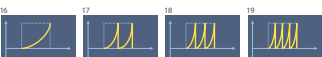
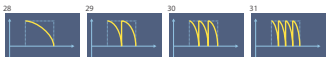
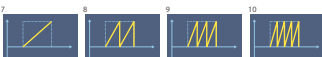
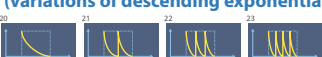
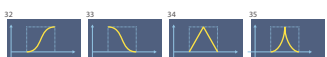
Waveform	Selects the waveform of the LFO.	
	SIN (LFO 1)	Sine wave
	TRI (LFO 2)	Triangle wave
	SAW	Sawtooth wave
	SQR	Square wave
	RND	Random wave
	S&H	Sample & Hold wave (one time per cycle, LFO value is changed)
	STEP	A waveform generated by the data specified by LFO Step 1-16. This produces stepped change with a fixed pattern similar to a step modulator.
Rate Note Sync Switch	OFF, ON	Set this ON if you want the LFO rate to synchronize with the tempo.
Rate	0-255	This is effective if Rate Sync is OFF. Specifies the LFO rate without regard to the tempo. Higher values produce a faster LFO rate (a shorter cycle).
Rate Note	This is effective if Rate Sync is ON. Specifies the LFO rate in terms of a note value. 4, 2, 1., 2T, 1, 1/2., 1T, 1/2, 1/4., 1/2T, 1/4, 1/8., 1/4T, 1/8, 1/16., 1/8T, 1/16, 1/32., 1/16T, 1/32, 1/32T, 1/64, 1/64T	
Key Trigger Switch	OFF, ON	Sets whether to synchronize the start of the LFO cycle with the timing you use when pressing the keys ("ON" to synchronize, "OFF" to disable).
Delay Time	0-255	Sets the time it takes before the LFO effect is applied after you press a key.
Fade Time	0-255	Specifies the time it takes for the LFO to reach its maximum amplitude after it begins to be applied.
Step Length	1-16	This is effective if Waveform is STEP. Sets the step size for looping.
Step 1-16	-72-0-+72	This is effective if Waveform is STEP. Specify the Depth value of each step. When this is set in scale (100 cent) units, you can use Assign to select OSC1 (or OSC2) Pitch, and set step in units of six (six steps equals a semitone) to change the octave over a range of ±1 octaves.

Step Curve 1-16	Step Curve 0 	Step Curve 11-15 (variations of descending saw) 	Step Curve 24-27 (variations of ascending charging curve) 
	Step Curve 1-6 (variations of square wave) 	Step Curve 16-19 (variations of ascending exponential) 	Step Curve 28-31 (variations of descending charging curve) 
	Step Curve 7-10 (variations of ascending saw) 	Step Curve 20-23 (variations of descending exponential) 	Step Curve 32-36 (other variations) 
			

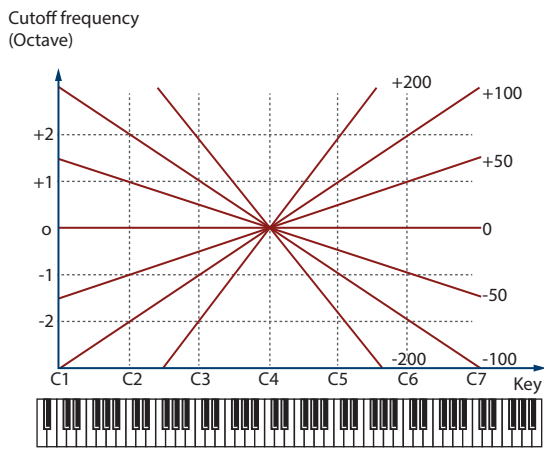
Parameter	Value	Explanation
Asgn 1-4		Select the parameter to which you want to assign the LFO. OFF, LFO2 RATE (LFO1), LFO1 RATE (LFO2), OSC1 PITCH, OSC2 PITCH, OSC3 PITCH, OSC1 POS, OSC2 SHAPE, OSC3 SHAPE, PITCH DEPTH, PITCH ATK, PITCH DCY, XMOD, OSC1 LEVEL, OSC2 LEVEL, OSC3 LEVEL, DRIVE, CUTOFF, RES, FENV DEPTH, FENV-ATK, FENV-DCY, FENV-SUS, FENV-REL, AENV-ATK, AENV-DCY, AENV-SUS, AENV-REL, LEVEL, MFX1 (changes according to the assigned MFX Type), MFX2 (changes according to the assigned MFX Type), MFX3 (changes according to the assigned MFX Type), REV1 (changes according to the assigned REV/DLY Type), REV2 (changes according to the assigned REV/DLY Type), REVERB LEVEL, OSC1 P-MOD X, OSC1 P-MOD Y, OSC1 S-MOD DPT, OSC1 S-MOD DRV
Asgn 1-4 Depth	-63-0+63	Adjusts the depth of the LFO applied to the assigned parameter.
FILTER		
Type		Selects the type of filter.
	LPF	Low pass filter. This cuts off frequencies above the cutoff frequency. Cutting off the high frequencies makes the sound more mellow. This is the most frequently-used type.
	BPF	Band pass filter. This cuts off frequencies except for those around the cutoff frequency. This filter type is useful for making sounds with a unique character.
	HPF	High pass filter. This cuts off frequencies below the cutoff frequency. This filter type is useful for creating percussion sounds and the like that have a distinctive high end.
Slope	-12, -18, -24 [dB/oct]	Selects the filter slope.
Cutoff Freq	0-255	Sets the frequency at which the filter that is applied to the frequency components of the waveform begins to take effect (the cutoff frequency).
Resonance	0-255	Emphasizes the portion of the sound around the cutoff frequency, adding character to the sound. Excessively high settings can produce oscillation, causing the sound to distort.
Cutoff Key Follow	-200-0+200	Set this to make the cutoff frequency change according to the keys you play. 
Drive	0-255	Adjusts how much the filter distorts the signal.
Drive Makeup Sens	-60-0 [dB]	Adjusts the output level from the filter when Drive is applied. Adjusts the volume with distortion still applied.

Parameter	Value	Explanation
Cutoff Velocity Sens	-100-0-+100	Sets how much the cutoff frequency changes according to how hard you play the keys. Set this to a "+" value to increase the cutoff frequency when you play harder, and set this to a "-" value to decrease the cutoff frequency when you play harder.
Reso Velocity Sens	-100-0-+100	Sets how much the resonance depth changes in response to how hard you play the keys. Set this to a "+" value to make the resonance increase when you play harder, and set this to a "-" value to make the resonance decrease when you play harder.

FILTER ENVELOPE

Depth	-63-0-+63	Specifies the depth of the Filter envelope. Higher settings increase the change produced by the Filter envelope. Negative (-) value will invert the shape of the envelope.
Velocity Sens	-100-0-+100	Use this to set how much the filter envelope changes in response to how hard you play the keys. Specify a positive "+" value if you want the filter envelope to apply more deeply as you play more strongly, or a negative "-" value if you want it to apply less deeply.
Attack Time	0-255	Adjusts the time it takes for the cutoff frequency to reach the maximum level from the time that a key is pressed.
Decay Time	0-255	Adjusts the time it takes for the envelope to reach the sustain level after the cutoff frequency reaches maximum.
Sustain Level	0-255	Adjusts the cutoff frequency used when the envelope has passed its attack and decay times, before you take your finger off the key.
Release Time	0-255	Adjusts the time it takes for the cutoff frequency to fall to minimum level after you take your finger off the key.

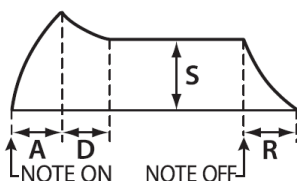

AMP

Level	0-127	Adjusts the volume of the tone.
Tone	-63-0-+63	Adjusts the tonal character of the tone.
Velocity Sens	-100-0-+100	Sets how much the volume changes according to how hard you play the keys. Set this to a "+" value to make the volume louder when you play harder, and set this to a "-" value to make the volume softer when you play harder.

AMP ENVELOPE

Attack Time	0-255	Adjusts the time it takes for the volume to reach maximum from the moment you play a key.
Decay Time	0-255	Adjusts the time it takes for the envelope to fall to the sustain level after the volume reaches maximum.
Sustain Level	0-255	Adjusts the volume used when the envelope has passed its attack and decay times, before you take your finger off the key.
Release Time	0-255	Adjusts the time it takes for the volume to fall to minimum after you take your finger off the key.

CONTROL

Pedal Func	Specifies the function assigned to the pedal connected to the PEDAL jack. OFF, MODULATION, HOLD1, EXPRESSION, VOLUME, PAN, BEND DOWN, BEND UP, HOLD SW, MONO SW, MFX SW, CHO LEVEL, REV LEVEL, REV SEND, BEND MODE, ARP SW, ARP SHUFFLE, ARP DURATION, START/STOP, TAP TEMPO, TONE DOWN, TONE UP
------------	--

Parameter	Value	Explanation
Pedal Pole	STANDARD, REVERSE	Specifies the polarity of the pedal connected to the PEDAL jack.
Keyboard Velocity	REAL, FIXED	Specifies whether the velocity value changes according to the actual strength of your playing (REAL) or is always a fixed velocity value regardless of how you play (FIXED).
Key Fixed Velocity	1–127	Sets the velocity used when Keyboard Velocity is “FIXED”.
Bend Up Range	0–24 (semitone)	<p>Sets how much the pitch changes (in semitones) when the pitch wheel is moved to its highest point.</p> <p>For example, when this is set to “24” and you push the pitch wheel all the way up (away from you), the pitch goes up two octaves.</p> <p>* The pitch may not reach the value that you set, depending on the sound parameter settings.</p>
Bend Down Range	0–24 (semitone)	<p>Sets how much the pitch changes (in semitones) when the pitch wheel is moved to its lowest point.</p> <p>For example, when this is set to “24” and you push the pitch wheel all the way down (towards you), the pitch goes down two octaves.</p>
Bend Mode	NORMAL	The pitch bend effect works normally.
	C+L (CATCH + LAST)	The pitch bend effect applies only to the last-played note. If a note-on occurs while pitch bend is already applied, the new note sounds at the center pitch. The pitch starts changing only after the controller passes through the center position.
Mod Mode	This selects the parameter to which modulation is applied when you operate the MOD wheel. PIT-LFO, FLT-LFO, AMP-LFO, CUTOFF, OSC1-POS, OSC1-PMOD-X, OSC1-PMOD-Y, OSC1-SMOD-DEPTH, OSC1-SMOD-DRIVE	
Mod LFO Source	LFO1, LFO2	Selects the LFO controlled by the MOD wheel.
Mod LFO Rate Sens	-63–0–+63	Adjusts how much the rate changes according to the modulation amount. With greater values, the rate gets faster according to the amount of modulation.
Mod Sens	-63–0–+63	Adjusts the depth at which the MOD wheel affects the LFO.
Mod OSC1 Pitch LFO Sw	OFF, ON	Sets whether to apply Pitch LFO to OSC1 using the MOD wheel (ON) or not (OFF).
Mod OSC2 Pitch LFO Sw	OFF, ON	Sets whether to apply Pitch LFO to OSC2 using the MOD wheel (ON) or not (OFF).
Mod OSC3 Pitch LFO Sw	OFF, ON	Sets whether to apply Pitch LFO to OSC3 using the MOD wheel (ON) or not (OFF).
REV/DLY Knob Mode	LEVEL, SEND	Switches the functions of the REVERB/DELAY [LEVEL] knob and the [SEND] knob (+ SHIFT operation).
FX Order	This sets the routing for the MFX, CHO and REV/DLY.	
	MFX->CHO->REV	
	MFX->REV->CHO	
	CHO->MFX->REV	
	CHO->REV->MFX	
	REV->MFX->CHO	
	REV->CHO->MFX	

MFx parameters assignment list

	MFx Type	MFx CTRL1		MFx CTRL2		MFx CTRL3	
		Parameter	LFO Asgn	Parameter	LFO Asgn	Parameter	LFO Asgn
Filter	Equalizer	Mid1 Freq	—	Mid1 Gain	—	Mid1 Q	—
	SuperFilter	Filter Cutoff	✓	Filter Resonance	✓	Rate *1	✓
	MM Filter	Filter Type	✓	Filter Tone	✓	Filter Color	✓
	Enhancer	Sens	✓	High Gain	—	Mix	✓
	Humanizer	Rate *1	✓	Vowel1	—	Vowel2	—
	Side Band Filter	Band Interval	✓	Band Width	✓	Balance	✓
	Resonator	Root	✓	Chord	✓	Bright	✓
Phaser	Phaser	Mode	—	Rate *1	✓	Depth	—
	Script 90	High Gain	—	Speed	✓	Depth	—
	Script 100	Resonance	✓	Rate *1	✓	Mix	✓
	Step Phaser	Manual	✓	Rate *1	✓	Step Rate *1	✓
	M StagePhsr	Rate *1	✓	Resonance	✓	Mix	✓
	Inf Phaser	Speed	✓	Resonance	✓	Mix	✓
Flanger	Flanger	Rate *1	✓	Depth	—	Feedback	✓
	SBF-325	Rate *1	✓	Depth	✓	Manual	✓
Chorus	Hexa-Chorus	Rate *1	✓	Depth	—	Balance	✓
	Trem Chorus	Chorus Rate	✓	Tremolo Rate *1	✓	Balance	✓
	Space-D	Rate *1	✓	Depth	—	Balance	✓
	CE-1	Intensity	✓	Low Gain	—	Hi Gain	—
	SDD-320	Mode	✓	Low Gain	—	Hi Gain	—
Modulation	Auto Pan	Mod Wave	—	Rate *1	✓	Depth	✓
	Slicer	Rate *1	✓	Attack	✓	Shuffle	✓
	VK Rotary	Speed	✓	Brake	✓	Spread	—
	Scatter	Type	✓	Depth	✓	Scatter Switch	✓
	To-Gu-Ro	Depth	✓	Rate *1	✓	Resonance	✓
	Downer	Depth	✓	Rate *1	✓	Filter	✓
Drive/Amp	Overdrive	Drive	✓	Tone	✓	Amp Type	—
	Distortion	Drive	✓	Tone	✓	Amp Type	—
	Fuzz	Drive	✓	Tone	✓	Level	—
	Fattener	Odd Level	✓	Even Level	✓	Level	—
	Saturator	Drive	✓	DrvPost3 Freq	—	DrvPost3 Gain	—
	W Saturator	Drive	✓	EQ Low Gain	✓	Drive Balance	✓
	Gt Amp Sim	Pre Amp Drive	✓	Pre Amp Master	✓	Direct Level	—
	EP Amp Sim	Speaker Type	—	Tremolo Speed *1	✓	Tremolo Depth	✓
	Speaker Sim	Speaker Type	—	Mic Level	✓	Direct Level	✓

	MFX Type	MFX CTRL1		MFX CTRL2		MFX CTRL3	
		Parameter	LFO Asgn	Parameter	LFO Asgn	Parameter	LFO Asgn
Comp/Limiter	Compressor	Threshold	✓	Attack	✓	Post Gain	—
	Limiter	Threshold	✓	Release	✓	Post Gain	—
	Sustainer	Sustain	✓	Attack	✓	Post Gain	—
	Transient	Attack	✓	Release	✓	Output Gain	—
Delay	Delay	Feedback	✓	HF Damp	—	Balance	✓
	Mod Delay	Feedback	✓	Rate *1	—	Balance	✓
	2Tap PanDly	Delay Time *1	✓	Delay Feedback	✓	Balance	✓
	3Tap PanDly	Center Feedback	✓	HF Damp	—	Balance	✓
	ReverseDly	Rev Delay Feedback	✓	Delay 3 Feedback	✓	Balance	✓
	Tape Echo	Repeat Rate	✓	Intensity	✓	Echo Level	—
Looper	DJFX Looper	Length	✓	Speed	✓	Loop Sw	✓
	BPM Looper	Length	✓	On Timing	—	On Length	—
Lo-fi	LOFi Comp	LoFi Type	—	Post Filter Cutoff	—	Balance	✓
	Bit Crusher	Sample Rate	✓	Bit Down	—	Filter	✓
	Phonograph	Frequency Range	—	Total Noise Lev	✓	Total W/F	✓
Pitch	Pitch Shifter	Coarse	✓	Feedback	✓	Balance	✓
	2Voice Pitch Shifter	Pitch1 Coarse	✓	Pitch2 Coarse	✓	Balance	✓
Combination	JD Multi	DS Drive	✓	PH Mix	✓	EH Mix	✓

*1 When Rate Sync Switch is ON, the Rate changes depending on the note you play. LFO assign is disabled.
When Rate Sync Switch is OFF, the Rate changes in Hz or in msec.

MFX Common Parameters

Parameter	Value	Explanation
Type	00–53	Selects the MFX type.
Switch	OFF, ON	Switches the MFX on/off.

00 Thru

Filter

01 Equalizer

This is a four-band stereo equalizer (low, mid x 2, high).



Parameter	Value	Explanation
Low Freq	20, 25, 31, 40, 50, 63, 80, 100, 125, 160, 200, 250, 315, 400 [Hz]	Frequency of the low range
Low Gain	-15--+15 [dB]	Amount of boost/cut for the low-frequency range
Mid1 Freq	200, 250, 315, 400, 500, 630, 800, 1000, 1250, 1600, 2000, 2500, 3150, 4000, 5000, 6300, 8000 [Hz]	Frequency of the middle range 1
Mid1 Gain	-15--+15 [dB]	Gain of the middle range 1
Mid1 Q	0.5, 1.0, 2.0, 4.0, 8.0	Width of the middle range 1. Set a higher value for Q to narrow the range to be affected.
Mid2 Freq	200, 250, 315, 400, 500, 630, 800, 1000, 1250, 1600, 2000, 2500, 3150, 4000, 5000, 6300, 8000 [Hz]	Frequency of the middle range 2
Mid2 Gain	-15--+15 [dB]	Gain of the middle range 2
Mid2 Q	0.5, 1.0, 2.0, 4.0, 8.0	Width of the middle range 2. Set a higher value for Q to narrow the range to be affected.
HighFreq	2000, 2500, 3150, 4000, 5000, 6300, 8000, 10000, 12500, 16000 [Hz]	Frequency of the high range
High Gain	-15--+15 [dB]	Amount of boost/cut for the high-frequency range
Level	0-127	Output Level

02 SuperFilter

This is a filter with an extremely sharp slope. The cutoff frequency can be varied cyclically.

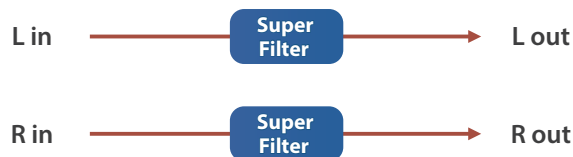

Parameter	Value	Explanation
Type	LPF, BPF, HPF, NOTCH	Filter type. Frequency range that will pass through each filter. LPF: Frequencies below the cutoff BPF: Frequencies in the region of the cutoff HPF: Frequencies above the cutoff NOTCH: Frequencies other than the region of the cutoff
Slope	-12, -24, -36 [dB]	The slope of the filter (attenuation characteristics; amount of attenuation per octave). -12 dB: Gentle -24 dB: Steep -36 dB: Extremely steep
Cutoff	0–127	Cutoff frequency of the filter. Increasing this value will raise the cutoff frequency.
Resonance	0–100	Filter resonance level. Increasing this value will emphasize the region near the cutoff frequency.
Gain	0–+12 [dB]	Amount of boost for the filter output
Mod Sw	OFF, ON	On/off switch for cyclic change
Mod Wave	TRI, SQR, SIN, SAW1, SAW2	How the cutoff frequency will be modulated. TRI: Triangle wave SQR: Square wave SIN: Sine wave SAW1: Sawtooth wave (upward) SAW2: Sawtooth wave (downward)
Rate Sync	OFF, ON	If this is ON, the rate synchronizes with the tempo of the rhythm.
Rate	0.05–10.00 [Hz]	Frequency of modulation
Rate Note	Note	1/64T, 1/64, 1/32T, 1/32, 1/16T, 1/32., 1/16, 1/8T, 1/16., 1/8, 1/4T, 1/8., 1/4, 1/2T, 1/4., 1/2, 1T, 1/2., 1, 2T, 1., 2
Depth	0–127	Depth of modulation
Attack	0–127	Speed at which the cutoff frequency will change This is effective if Mod Wave is SQR, SAW1, or SAW2.
Level	0–127	Output Level

03 MM Filter (Multi-mode Filter)

This is a filter that is adjusted for effective use in a DJ performance.

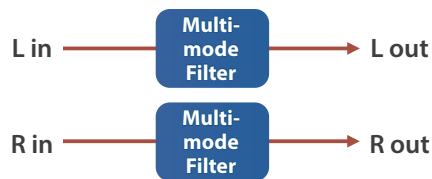

Parameter	Value	Explanation
Type	LPF/HPF, LPF, HPF, BPF	Filter type. LPF/HPF: The filter type is automatically switched according to the Filter Tone parameter value.
Tone	0–255	Frequency at which the filter operates
Color	0–255	The filter's resonance level. Higher values more strongly emphasize the region of the operating frequency.
Slope	-12, -24, -36 [dB]	The slope of the filter (attenuation characteristics; amount of attenuation per octave). -12 dB: Gentle -24 dB: Steep -36 dB: Extremely steep
Gain	0–+12 [dB]	Amount of boost for the filter output
Level	0–127	Output Level

04 Enhancer

Controls the overtone structure of the high frequencies, adding sparkle and tightness to the sound.

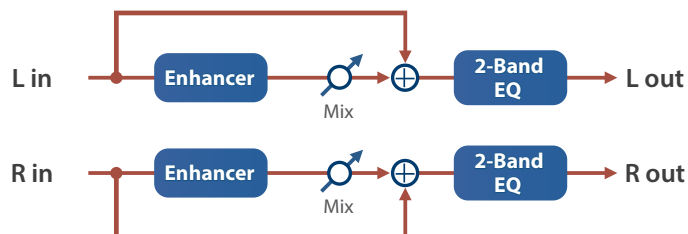

Parameter	Value	Explanation
Sens	0–127	Sensitivity of the enhancer
Mix	0–127	Level of the overtones generated by the enhancer
Low Gain	-15–+15 [dB]	Amount of boost/cut for the low-frequency range
High Gain	-15–+15 [dB]	Amount of boost/cut for the high-frequency range
Level	0–127	Output Level

05 Humanizer

Adds a vowel character to the sound, making it similar to a human voice.

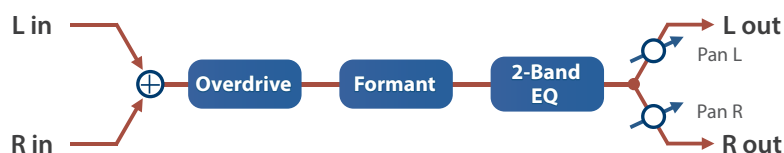

Parameter	Value	Explanation
Drive Sw	OFF, ON	Overdrive on/off
Drive	0–127	The degree of distortion. Also changes the volume.
Vowel1	a, e, i, o, u	Vowel 1
Vowel2	a, e, i, o, u	Vowel 2
Rate Sync	OFF, ON	If this is ON, the rate synchronizes with the tempo of the rhythm.
Rate	0.05–10.00 [Hz]	Frequency at which the two vowels switch
Rate Note	Note	1/64T, 1/64, 1/32T, 1/32, 1/16T, 1/32., 1/16, 1/8T, 1/16., 1/8, 1/4T, 1/8., 1/4, 1/2T, 1/4., 1/2, 1T, 1/2., 1, 2T, 1., 2
Depth	0–127	Effect depth
In Sync Sw	OFF, ON	Turns LFO reset on/off. Determines whether the LFO for switching the vowels is reset by the input signal (ON) or not (OFF).
InSyncThres	0–127	Volume level at which reset is applied
Manual	0–100	Point at which Vowel 1/2 switch 0–49: Vowel 1 will have a longer duration. 50: Vowel 1 and 2 will be of equal duration. 51–100: Vowel 2 will have a longer duration.
Low Gain	-15–+15 [dB]	Amount of boost/cut for the low-frequency range
High Gain	-15–+15 [dB]	Amount of boost/cut for the high-frequency range
Pan	L64–63R	Stereo location of the output sound
Level	0–127	Output Level

06 Side Band Filter

A sideband filter that only allows specific frequency components to pass through.

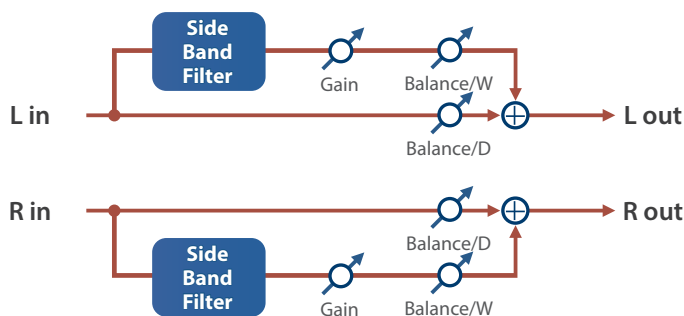

Parameter	Value	Explanation
Band Interval	0–100	The band interval. Larger values produce wider band intervals, and the frequency of each band increases.
Band Width	0–100	The bandwidth setting. Larger values produce a narrower bandwidth, which further isolates the specific frequency components that pass through the filter.
Balance	D100:0W–D0:100W	Volume balance between the sound that is sent through the sideband filter (W) and the sound that is not sent through the sideband filter (D).
Type	SBF1, SBF2, SBF3, SBF4, SBF5, SBF6	The range in which the filter works.
Gain	0–+18 [dB]	Output gain for the sound that passes through the sideband filter
Level	0–127	Output Level

07 Resonator

This effect uses “Karplus-Strong synthesis”, which is often used in physical modeling of sounds. This lets you alter the sound with a maximum of six “resonators” that match different keys or chords.

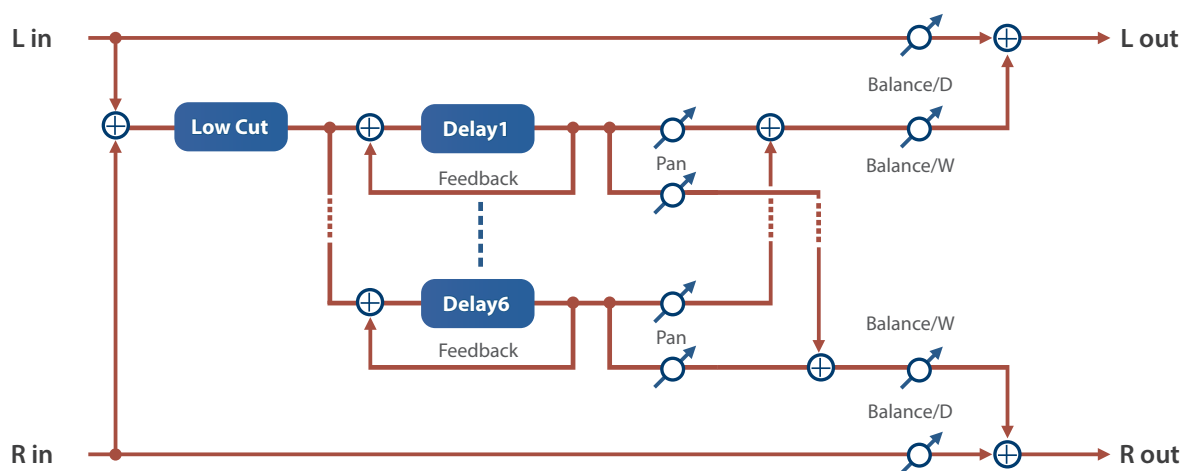

Parameter	Value	Explanation
Root	C-1-G9	Fundamental tone (root)
Bright	0-100	Brilliance
Feedback	0-99 [%]	Amount of resonator sound fed back to the input
Chord	Composite notes (chord) to resonate Root, Oct, UpDn, P5, m3, m5, m7, m7oct, m0, m11, M3, M5, M7, M7oct, M9, M11	
Panning	0-100	Panning for the resonator
Env Mod Depth	0-100	Adjusts the amount of feedback according to the input level. Larger values increase the amount of feedback according to the input level.
Balance	D100:0W-D0:100W	Volume balance between the sound that is sent through the resonator (W) and the sound that is not sent through the resonator (D).
Low Cut Frequency	The base frequency used to cut the low-band audio of the resonator input sound (FLAT : no cut). FLAT, 20, 25, 31, 40, 50, 63, 80, 100, 125, 160, 200, 250, 315, 400, 500, 630, 800 [Hz]	
Level	0-127	Output Level

Phaser

08 Phaser

This is a stereo phaser. A phase-shifted sound is added to the original sound and modulated.

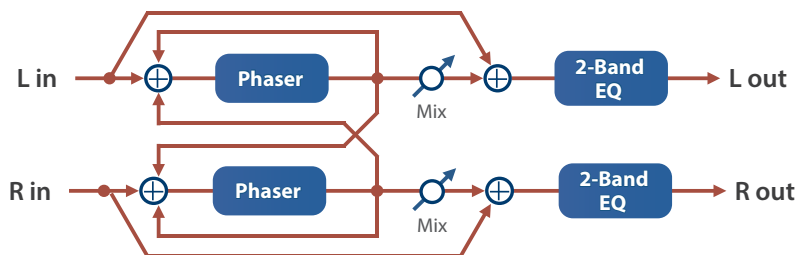

Parameter	Value	Explanation
Mode	4-STAGE, 8-STAGE, 12-STAGE	Number of stages in the phaser
Manual	0–127	Adjusts the basic frequency from which the sound will be modulated.
Rate Sync	OFF, ON	If this is ON, the rate synchronizes with the tempo of the rhythm.
Rate	0.05–10.00 [Hz]	Frequency of modulation
Rate Note	Note	1/64T, 1/64, 1/32T, 1/32, 1/16T, 1/32., 1/16, 1/8T, 1/16., 1/8, 1/4T, 1/8., 1/4, 1/2T, 1/4., 1/2, 1T, 1/2., 1, 2T, 1., 2
Depth	0–127	Depth of modulation
Polarity	INVERSE, SYNCHRO	The left/right modulation phase. INVERSE: Left/right phases inverted When using a mono source, this spreads the sound. SYNCHRO: Left/right phases synchronized Select this when inputting a stereo source.
Resonance	0–127	Amount of feedback
Feedback	-98–+98 [%]	Adjusts the proportion of the phaser sound that is fed back into the effect (Negative values invert the phase).
Mix	0–127	Level of the phase-shifted sound
Low Gain	-15–+15 [dB]	Amount of boost/cut for the low-frequency range
High Gain	-15–+15 [dB]	Amount of boost/cut for the high-frequency range
Level	0–127	Output Level

09 Script 90

This simulates a different analog phaser than Small Phaser.

It is particularly suitable for electric piano.

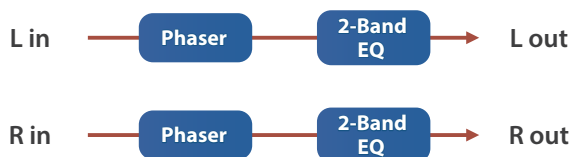

Parameter	Value	Explanation
Speed	0–100	Speed of modulation
Depth	0–127	Depth of modulation
Low Gain	-15–+15 [dB]	Amount of boost/cut for the low-frequency range
High Gain	-15–+15 [dB]	Amount of boost/cut for the high-frequency range
Level	0–127	Output Level

10 Script 100

This simulates an analog phaser of the past.

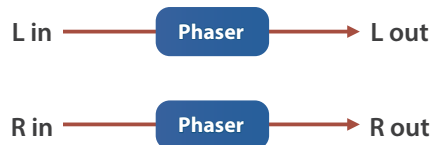

Parameter	Value	Explanation
Rate Sync	OFF, ON	If this is ON, the rate synchronizes with the tempo of the rhythm.
Rate	0.05–10.00 [Hz]	Frequency of modulation
Rate Note	Note	1/64T, 1/64, 1/32T, 1/32, 1/16T, 1/32., 1/16, 1/8T, 1/16., 1/8, 1/4T, 1/8., 1/4, 1/2T, 1/4., 1/2, 1T, 1/2., 1, 2T, 1., 2
Duty	-50–50	Adjusts the speed ratio between the rising and falling modulation phase cycles.
Min	0–100	Lower limit reached by modulation
Max	0–100	Upper limit reached by modulation
Manual Sw	OFF, ON	Applies modulation according to the value of the Manual parameter, rather than modulating automatically.
Manual	0–100	Adjusts the basic frequency from which the sound will be modulated.
Resonance	0–66	Amount of feedback
Mix	0–127	Level of the phase-shifted sound
Level	0–127	Output Level

11 Step Phaser

This is a stereo phaser. The phaser effect will be varied gradually.

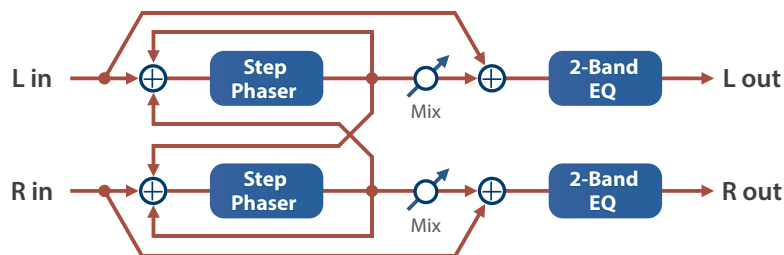

Parameter	Value	Explanation
Mode	4-STAGE, 8-STAGE, 12-STAGE	Number of stages in the phaser
Manual	0–127	Adjusts the basic frequency from which the sound will be modulated.
Rate Sync	OFF, ON	If this is ON, the rate synchronizes with the tempo of the rhythm.
Rate	0.05–10.00 [Hz]	Frequency of modulation
Rate Note	Note	1/64T, 1/64, 1/32T, 1/32, 1/16T, 1/32., 1/16, 1/8T, 1/16., 1/8, 1/4T, 1/8., 1/4, 1/2T, 1/4., 1/2, 1T, 1/2., 1, 2T, 1., 2
Depth	0–127	Depth of modulation

Parameter	Value	Explanation
Polarity	INVERSE, SYNCHRO	The left/right modulation phase. INVERSE: Left/right phases inverted When using a mono source, this spreads the sound. SYNCHRO: Left/right phases synchronized Select this when inputting a stereo source.
Resonance	0–127	Amount of feedback
Feedback	-98–+98 [%]	Adjusts the proportion of the phaser sound that is fed back into the effect (Negative values invert the phase).
S Rate Sync	OFF, ON	If this is ON, the rate synchronizes with the tempo of the rhythm.
S.Rate	0.10–20.00 [Hz]	Rate of the step-wise change in the phaser effect
S.Rate Nt	Note	1/64T, 1/64, 1/32T, 1/32, 1/16T, 1/32., 1/16, 1/8T, 1/16., 1/8, 1/4T, 1/8., 1/4, 1/2T, 1/4., 1/2, 1T, 1/2., 1, 2T, 1., 2
Mix	0–127	Level of the phase-shifted sound
Low Gain	-15–+15 [dB]	Amount of boost/cut for the low-frequency range
High Gain	-15–+15 [dB]	Amount of boost/cut for the high-frequency range
Level	0–127	Output Level

12 M StagePhsr (Multi Stage Phaser)

Extremely high settings of the phase difference produce a deep phaser effect.

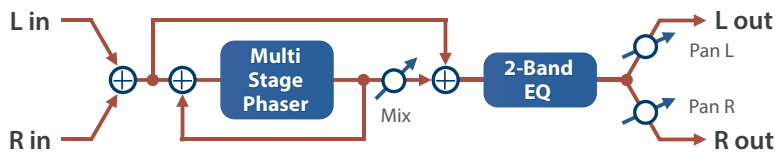

Parameter	Value	Explanation
Mode	4-STAGE, 8-STAGE, 12-STAGE, 16-STAGE, 20-STAGE, 24-STAGE	Number of stages in the phaser
Manual	0–127	Adjusts the basic frequency from which the sound will be modulated.
Rate Sync	OFF, ON	If this is ON, the rate synchronizes with the tempo of the rhythm.
Rate	0.05–10.00 [Hz]	Frequency of modulation
Rate Note	Note	1/64T, 1/64, 1/32T, 1/32, 1/16T, 1/32., 1/16, 1/8T, 1/16., 1/8, 1/4T, 1/8., 1/4, 1/2T, 1/4., 1/2, 1T, 1/2., 1, 2T, 1., 2
Depth	0–127	Depth of modulation
Resonance	0–127	Amount of feedback
Mix	0–127	Level of the phase-shifted sound
Pan	L64–63R	Stereo location of the output sound
Low Gain	-15–+15 [dB]	Amount of boost/cut for the low-frequency range
High Gain	-15–+15 [dB]	Amount of boost/cut for the high-frequency range
Level	0–127	Output Level

13 Inf Phaser (Infinite Phaser)

A phaser that continues raising/lowering the frequency at which the sound is modulated.



Parameter	Value	Explanation
Mode	1–4	Higher values will produce a deeper phaser effect.
Speed	-100–+100	The frequency at which the sound modulation rise and falls (+: upward / -: downward).
Resonance	0–127	Amount of feedback
Mix	0–127	Level of the phase-shifted sound
Pan	L64–63R	Stereo location of the output sound
Low Gain	-15–+15 [dB]	Amount of boost/cut for the low-frequency range
High Gain	-15–+15 [dB]	Amount of boost/cut for the high-frequency range
Level	0–127	Output Level

Flanger

14 Flanger

This is a stereo flanger (The left/right phases of the LFO are synchronized).

It produces a metallic resonance that rises and falls like a jet airplane taking off or landing.

A filter is provided so that you can adjust the timbre of the flanged sound.

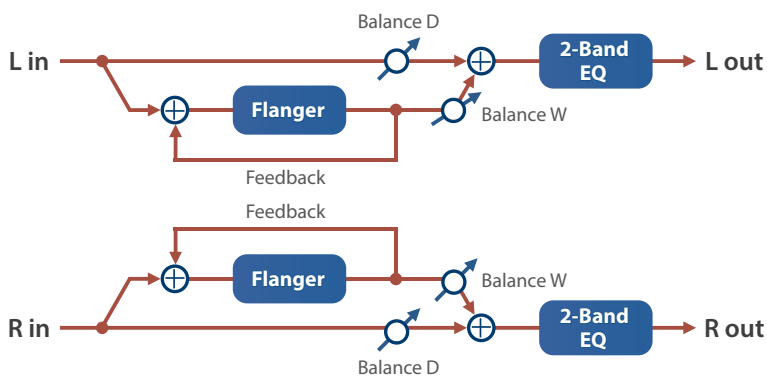

Parameter	Value	Explanation
Type	OFF, LPF, HPF	The filter type. OFF: No filter is used LPF: Cuts the frequency range above the Cutoff Freq HPF: Cuts the frequency range below the Cutoff Freq
Cutoff	Basic frequency of the filter 200, 250, 315, 400, 500, 630, 800, 1000, 1250, 1600, 2000, 2500, 3150, 4000, 5000, 6300, 8000 [Hz]	
Pre Delay	0.0–100 [ms]	Adjusts the delay time from the direct sound until the flanger sound is heard.
Rate Sync	OFF, ON	If this is ON, the rate synchronizes with the tempo of the rhythm.
Rate	0.05–10.00 [Hz]	Frequency of modulation

Parameter	Value	Explanation
Rate Note	Note	1/64T, 1/64, 1/32T, 1/32, 1/16T, 1/32., 1/16, 1/8T, 1/16., 1/8, 1/4T, 1/8., 1/4, 1/2T, 1/4., 1/2, 1T, 1/2., 1, 2T, 1., 2
Depth	0–127	Depth of modulation
Phase	0–180 [deg]	Spatial spread of the sound
Feedback	-98–+98 [%]	Adjusts the proportion of the flanger sound that is fed back into the effect (Negative values invert the phase).
Low Gain	-15–+15 [dB]	Amount of boost/cut for the low-frequency range
High Gain	-15–+15 [dB]	Amount of boost/cut for the high-frequency range
Balance	D100:0W–D0:100W	Volume balance between the direct sound (D) and the flanger sound (W)
Level	0–127	Output Level

15 SBF-325 (Flanger)

This effect reproduces Roland's SBF-325 analog flanger.

It provides three types of flanging effect (which adds a metallic resonance to the original sound) and a chorus-type effect.



Parameter	Value	Explanation
Mode	Types of flanging effect	
	FL1	A typical mono flanger
	FL2	A stereo flanger that preserves the stereo positioning of the original sound
	FL3	A cross-mix flanger that produces a more intense effect
CHO	A chorus effect	
Rate Sync	OFF, ON	If this is ON, the rate synchronizes with the tempo of the rhythm.
Rate	0.02–5.00 [Hz]	Modulation frequency of the flanger effect
Rate Note	Note	1/64T, 1/64, 1/32T, 1/32, 1/16T, 1/32., 1/16, 1/8T, 1/16., 1/8, 1/4T, 1/8., 1/4, 1/2T, 1/4., 1/2, 1T, 1/2., 1, 2T, 1., 2
Depth	0–127	Modulation depth of the flanger effect
Manual	0–127	Center frequency at which the flanger effect is applied
Feedback	0–127	The intensity of the flanging effect. If Mode is CHO, this setting is ignored.
RMod Phase	NORM, INV	The phase of the right channel modulation. Normally, you will leave this at Normal (NORM). If you specify Inverted (INV), the modulation (upward/downward movement) of the right channel is inverted.
L Phase	NORM, INV	The phase of the flanging sound when mixed with the original sound.
R Phase	NORM, INV	NORM: normal phase INV: inverse phase
Level	0–127	Output Level

Chorus

16 Hexa-Chorus

Uses a six-phase chorus (six layers of chorused sound) to give richness and spatial spread to the sound.

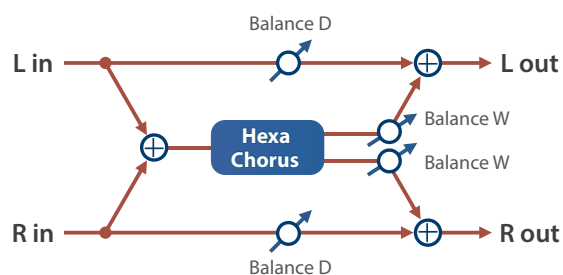

Parameter	Value	Explanation
Pre Delay	0.0–100 [ms]	Adjusts the delay time from the direct sound until the chorus sound is heard.
Rate Sync	OFF, ON	If this is ON, the rate synchronizes with the tempo of the rhythm.
Rate	0.05–10.00 [Hz]	Frequency of modulation
Rate Note	Note	1/64T, 1/64, 1/32T, 1/32, 1/16T, 1/32., 1/16, 1/8T, 1/16., 1/8, 1/4T, 1/8., 1/4, 1/2T, 1/4., 1/2, 1T, 1/2., 1, 2T, 1., 2
Depth	0–127	Depth of modulation
PreDly Dev	0–20	Adjusts the differences in Pre Delay between each chorus sound.
Depth Dev	-20–+20	Adjusts the difference in modulation depth between each chorus sound.
Pan Dev	0–20	The deviation in pan position for each chorus sound. 0: All chorus sounds will be in the center. 20: Each chorus sound will be spaced at 60 degree intervals relative to the center.
Balance	D100:0W–D0:100W	Volume balance between the direct sound (D) and the chorus sound (W)
Level	0–127	Output Level

17 Trem Chorus (Tremolo Chorus)

This is a chorus effect with added Tremolo (cyclic modulation of volume).

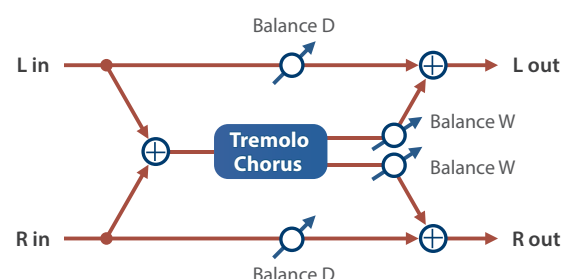

Parameter	Value	Explanation
Pre Delay	0.0–100 [ms]	Adjusts the delay time from the direct sound until the chorus sound is heard.
Cho Sync	OFF, ON	If this is ON, the rate synchronizes with the tempo of the rhythm.
C.Rate	0.05–10.00 [Hz]	Modulation frequency of the chorus effect
C.Rate Nt	Note	1/64T, 1/64, 1/32T, 1/32, 1/16T, 1/32., 1/16, 1/8T, 1/16., 1/8, 1/4T, 1/8., 1/4, 1/2T, 1/4., 1/2, 1T, 1/2., 1, 2T, 1., 2
Cho Depth	0–127	Modulation depth of the chorus effect
Trm Sync	OFF, ON	If this is ON, the rate synchronizes with the tempo of the rhythm.
T.Rate	0.05–10.00 [Hz]	Modulation frequency of the tremolo effect

Parameter	Value	Explanation
T.Rate Nt	Note	1/64T, 1/64, 1/32T, 1/32, 1/16T, 1/32., 1/16, 1/8T, 1/16., 1/8, 1/4T, 1/8., 1/4, 1/2T, 1/4., 1/2, 1T, 1/2., 1, 2T, 1., 2
Trm Separate	0–127	Depth of the tremolo effect
Trm Phase	0–180 [deg]	Spread of the tremolo effect
Balance	D100:0W–D0:100W	Volume balance between the direct sound (D) and the tremolo chorus sound (W)
Level	0–127	Output Level

18 Space-D

This is a multiple chorus that applies two-phase modulation in stereo. It gives no impression of modulation, but produces a transparent chorus effect.

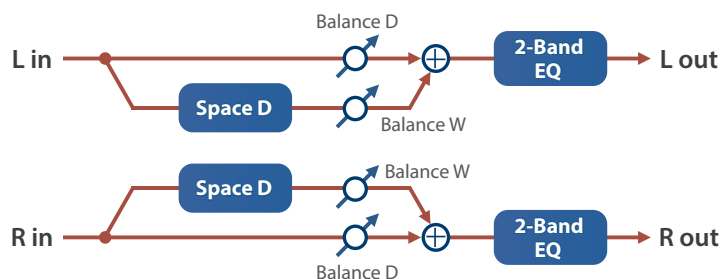

Parameter	Value	Explanation
Pre Delay	0.0–100 [ms]	Adjusts the delay time from the direct sound until the chorus sound is heard.
Rate Sync	OFF, ON	If this is ON, the rate synchronizes with the tempo of the rhythm.
Rate	0.05–10.00 [Hz]	Frequency of modulation
Rate Note	Note	1/64T, 1/64, 1/32T, 1/32, 1/16T, 1/32., 1/16, 1/8T, 1/16., 1/8, 1/4T, 1/8., 1/4, 1/2T, 1/4., 1/2, 1T, 1/2., 1, 2T, 1., 2
Depth	0–127	Depth of modulation
Phase	0–180 [deg]	Spatial spread of the sound
Low Gain	-15–+15 [dB]	Amount of boost/cut for the low-frequency range
High Gain	-15–+15 [dB]	Amount of boost/cut for the high-frequency range
Balance	D100:0W–D0:100W	Volume balance between the direct sound (D) and the chorus sound (W)
Level	0–127	Output Level

19 CE-1 (Chorus)

This models the classic BOSS CE-1 chorus effect unit.

It provides a chorus sound with a distinctively analog warmth.

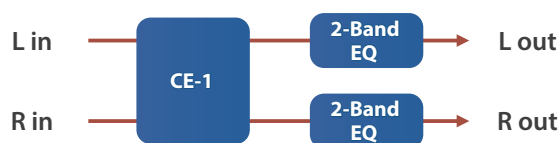

Parameter	Value	Explanation
Intensity	0–127	Chorus depth
Low Gain	-15–+15 [dB]	Amount of boost/cut for the low-frequency range
High Gain	-15–+15 [dB]	Amount of boost/cut for the high-frequency range
Level	0–127	Output Level

20 SDD-320 (DIMENSION D)

This models Roland's DIMENSION D (SDD-320). It provides a clear chorus sound.



Parameter	Value	Explanation
Mode	1, 2, 3, 4, 1+4, 2+4, 3+4	Switches the mode.
Low Gain	-15--+15 [dB]	Amount of boost/cut for the low-frequency range
High Gain	-15--+15 [dB]	Amount of boost/cut for the high-frequency range
Level	0-127	Output Level

Modulation

21 Auto Pan

Cyclically modulates the stereo location of the sound.

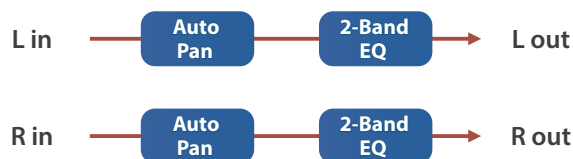

Parameter	Value	Explanation
Mod Wave	TRI, SQR, SIN, SAW1, SAW2, TRP	Sets how the pan position changes. TRI: Triangle wave SQR: Square wave SIN: Sine wave SAW1/2: Sawtooth wave TRP: Trapezoidal wave
Rate Sync	OFF, ON	If this is ON, the rate synchronizes with the tempo of the rhythm.
Rate	0.05-10.00 [Hz]	Frequency of the change
Rate Note	Note	1/64T, 1/64, 1/32T, 1/32, 1/16T, 1/16., 1/16, 1/8T, 1/16., 1/8, 1/4T, 1/8., 1/4, 1/2T, 1/4., 1/2, 1T, 1/2., 1, 2T, 1., 2
Depth	0-127	Depth to which the effect is applied
Low Gain	-15--+15 [dB]	Amount of boost/cut for the low-frequency range
High Gain	-15--+15 [dB]	Amount of boost/cut for the high-frequency range
Level	0-127	Output Level

22 Slicer

By applying successive cuts to the sound, this effect turns a conventional sound into a sound that appears to be played as a backing phrase. This is especially effective when applied to sustain-type sounds.

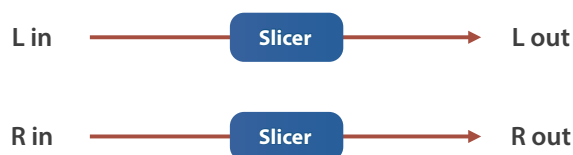

Parameter	Value	Explanation
Step 1–16	0–127	Level at each step
Rate Sync	OFF, ON	If this is ON, the rate synchronizes with the tempo of the rhythm.
Rate	0.05–10.00 [Hz]	Rate at which the 16-step sequence will cycle
Rate Note	Note	1/64T, 1/64, 1/32T, 1/32, 1/16T, 1/32., 1/16, 1/8T, 1/16., 1/8, 1/4T, 1/8., 1/4, 1/2T, 1/4., 1/2, 1T, 1/2., 1, 2T, 1., 2
Attack	0–127	Sets the speed at which the sound level changes between steps.
In Sync Sw	OFF, ON	Sets whether to restart the step sequence from the beginning according to the presence of input sound (ON) or not (OFF).
InSyncThres	0–127	Sets the volume at which an input sound is detected.
Mode	LEGATO, SLASH	<p>Sets how the volume changes when the slicer goes to the next step.</p> <p>LEGATO: The change in volume from one step's level to the next remains unaltered. If the level of a following step is the same as the one preceding it, there is no change in volume.</p> <p>SLASH: The level is momentarily set to 0 before progressing to the level of the next step.</p> <p>This change in volume occurs even if the level of the following step is the same as the preceding step.</p>
Shuffle	0–127	<p>Sets the timing at which the volume changes to that of the even-numbered steps (step 2, step 4, step 6...).</p> <p>The higher the value, the later the timing progresses.</p>
Level	0–127	Sets the output volume.

23 VK Rotary

This type provides modified response for the rotary speaker, with the low end boosted further.

This effect features the same specifications as the VK-7's built-in rotary speaker.

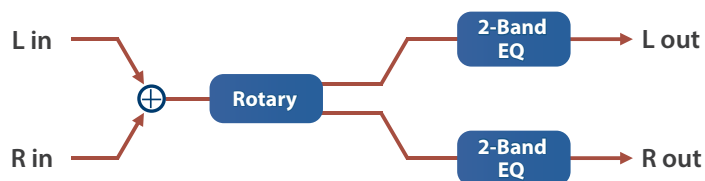

Parameter	Value	Explanation
Speed	SLOW, FAST	<p>The speaker rotation (cycle).</p> <p>SLOW: Slow</p> <p>FAST: Fast</p>
Brake	OFF, ON	<p>Turns the speaker rotation on/off.</p> <p>When this is turned on, the rotation will gradually stop. When it is turned off, the rotation will gradually resume.</p>

Parameter	Value	Explanation
Wf Slow	0.05–10.00 [Hz]	Low-speed rotation speed of the woofer
Wf Fast	0.05–10.00 [Hz]	High-speed rotation speed of the woofer
Wf Trs Up	0–127	Adjusts the rate at which the woofer rotation speeds up when the rotation is switched from Slow to Fast.
Wf Trs Dw	0–127	Adjusts the rate at which the woofer rotation speeds up when the rotation is switched from Fast to Slow.
Wf Level	0–127	Volume of the woofer
Tw Slow	0.05–10.00 [Hz]	The tweeter setting. The parameters are the same as for the woofer.
Tw Fast	0.05–10.00 [Hz]	
Tw Trs Up	0–127	
Tw Trs Dw	0–127	
Tw Level	0–127	
Spread	0–10	
Low Gain	-15–+15 [dB]	Amount of boost/cut for the low-frequency range
High Gain	-15–+15 [dB]	Amount of boost/cut for the high-frequency range
Level	0–127	Output Level
OD Switch	OFF, ON	Overdrive on/off
OD Gain	0–127	The overdrive input level. Higher values will increase the distortion.
OD Drive	0–127	Degree of distortion
OD Level	0–127	Volume of the overdrive

24 Scatter

This effect swaps the sound played back by a loop in steps, altering its playback direction and gate length. This produces a digital groove feel to the loop playback.

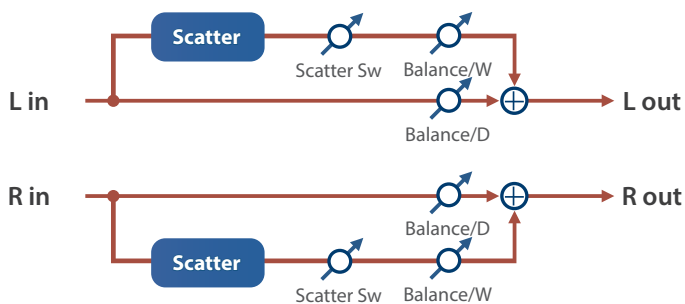

Parameter	Value	Explanation
Type	1–10	Scatter type
Depth	10, 20, 30, 40, 50, 60, 70, 80, 90, 100	Scatter depth
Scatter Switch	OFF, ON	Scatter effect on/off
Speed	SINGLE, DOUBLE	Scatter speed
Balance	D100:0W–D0:100W	Volume balance between the sound that is sent through the scatter (W) and the sound that is not sent through the scatter (D).
Level	0–127	Output Level

25 To-Gu-Ro

This gives the sound an undulating effect, based on the image of a coiled-up snake.

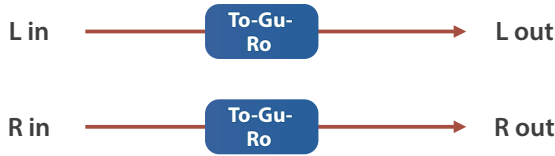

Parameter	Value	Explanation
Depth	0–100	Degree to which the playback speed should be slowed down
Rate Sync	OFF, ON	If this is ON, the rate synchronizes with the tempo of the rhythm.
Rate	0.05–10.00 [Hz]	Frequency of the change
Rate Note	Note	1/64T, 1/64, 1/32T, 1/32, 1/16T, 1/32., 1/16, 1/8T, 1/16., 1/8, 1/4T, 1/8., 1/4, 1/2T, 1/4., 1/2, 1T, 1/2., 1, 2T, 1., 2
Resonance	0–100	The filter's resonance level. Increasing the value further emphasizes the effect, for a more unusual sound.
Filter Mod Depth	0–100	Amount of high-range frequency attenuation according to the playback speed
Amp Mod Depth	0–100	Amount of attenuation according to the playback speed
Hold Switch	OFF, ON	Play/stop. When this is ON, the playback speed is near zero.
Level	0–127	Output Level

26 Downer

Cyclically slows down the playback speed of the sound.

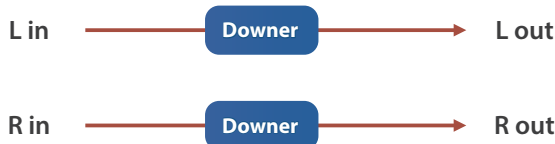

Parameter	Value	Explanation
Depth	0–100	Degree to which the playback speed should be slowed down
Rate Sync	OFF, ON	If this is ON, the rate synchronizes with the tempo of the rhythm.
Rate	0.05–10.00 [Hz]	Frequency of the change
Rate Note	Note	1/64T, 1/64, 1/32T, 1/32, 1/16T, 1/32., 1/16, 1/8T, 1/16., 1/8, 1/4T, 1/8., 1/4, 1/2T, 1/4., 1/2, 1T, 1/2., 1, 2T, 1., 2
Filter	0–100	The degree of attenuation of the filter's high-frequency range. Larger values increase the high-frequency range attenuation.
Pitch Switch	OFF, ON	Corrects the sound for changes in pitch. When this is turned ON, pitches that were lowered due to the change in speed are converted to their original pitch.
Resonance	0–100	The filter's resonance level. Increasing the value further emphasizes the effect, for a more unusual sound.
Level	0–127	Output Level

Drive / Amp

27 Overdrive

This is an overdrive that provides heavy distortion.

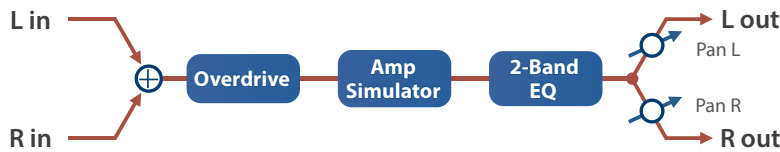

Parameter	Value	Explanation
Drive	0–127	The degree of distortion. Also changes the volume.
Tone	0–127	Sound quality of the Overdrive effect
Amp Switch	OFF, ON	Turns the Amp Simulator on/off.
AmpType	SMALL, BUILT-IN, 2-STACK, 3-STACK	The guitar amp type. SMALL: Small amp BUILT-IN: Single-unit type amp 2-STACK: Large double stack-type amp 3-STACK: Large triple stack-type amp
Low Gain	-15–+15 [dB]	Amount of boost/cut for the low-frequency range
High Gain	-15–+15 [dB]	Amount of boost/cut for the high-frequency range
Pan	L64–63R	Stereo location of the output sound
Level	0–127	Output Level

28 Distortion

Produces a more intense distortion than Overdrive.

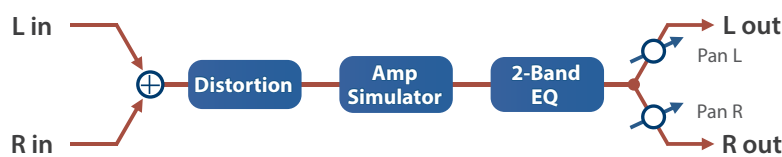

Parameter	Value	Explanation
Drive	0–127	The degree of distortion. Also changes the volume.
Tone	0–127	Sound quality of the Overdrive effect
Amp Switch	OFF, ON	Turns the Amp Simulator on/off.
AmpType	SMALL, BUILT-IN, 2-STACK, 3-STACK	The guitar amp type. SMALL: Small amp BUILT-IN: Single-unit type amp 2-STACK: Large double stack-type amp 3-STACK: Large triple stack-type amp
Low Gain	-15–+15 [dB]	Amount of boost/cut for the low-frequency range
High Gain	-15–+15 [dB]	Amount of boost/cut for the high-frequency range
Pan	L64–63R	Stereo location of the output sound
Level	0–127	Output Level

29 Fuzz

Adds overtones and intensely distorts the sound.

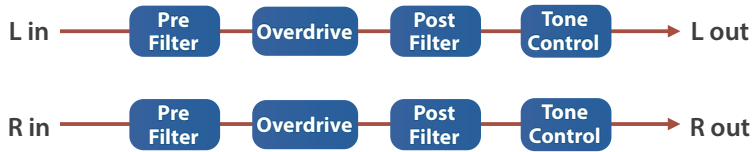

Parameter	Value	Explanation
Drive	0–127	Adjusts the depth of distortion. This also changes the volume.
Tone	0–100	Sound quality of the Overdrive effect
Level	0–127	Output Level

30 Fattener

This effect applies distinctive distortion, adding overtones to give more depth to the sound.

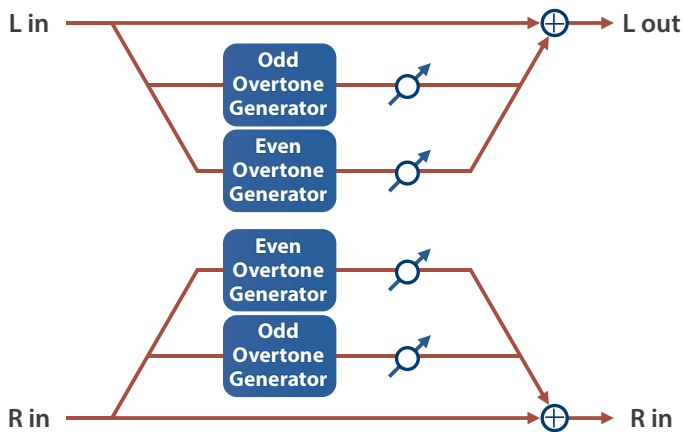

Parameter	Value	Explanation
Odd Level	0–400 [%]	Raising the value adds odd-order overtones.
Even Level	0–400 [%]	Raising the value adds even-order overtones.
Level	0–127	Output Level

31 Saturator

This effect combines overdrive and filter.

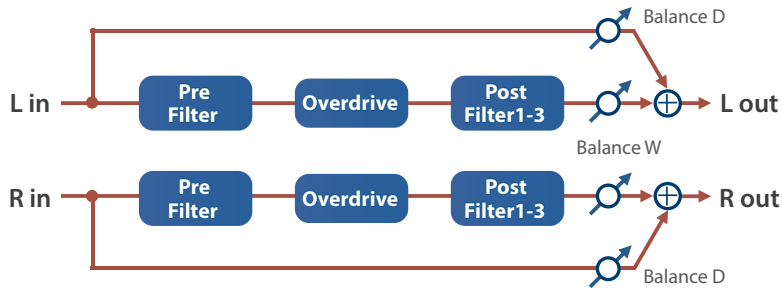

Parameter	Value	Explanation
Pre Type	THRU, LPF, HPF, LSV, HSV	The types of filters available before distortion processing. THRU: No filter is applied LPF: A filter that passes the sound below the specified frequency HPF: A filter that passes the sound above the specified frequency LSV: A filter that boosts/cuts the sound below the specified frequency HSV: A filter that boosts/cuts the sound above the specified frequency
Pre Freq	20–16000 [Hz]	Frequency at which the pre-distortion filter operates
Pre Gain	-24.0–+24.0 [dB]	For the LSV/HSV types, the amount of boost/cut
Drive	0.0–48.0 [dB]	Strength of distortion
Post1 Type	THRU, LPF, HPF, LSV, HSV	Type of filter 1 which follows the distortion processing
Post1 Frq	20–16000 [Hz]	Frequency at which post-distortion filter 1 operates
Post1 Gain	-24.0–+24.0 [dB]	For the LSV/HSV types, the amount of boost/cut
Post2 Type	THRU, LPF, HPF, LSV, HSV	Type of filter 2 which follows the distortion processing
Post2 Frq	20–16000 [Hz]	Frequency at which post-distortion filter 2 operates
Post2 Gain	-24.0–+24.0 [dB]	For the LSV/HSV types, the amount of boost/cut
Post3 Type	THRU, LPF, HPF, BPF, PKG	The filter types available for filter 3 after distortion processing. THRU: No filter is applied LPF: A filter that passes the sound below the specified frequency HPF: A filter that passes the sound above the specified frequency BPF: A filter that passes only the specified frequency PKG: A filter that boosts/cuts the specified frequency
Post3 Frq	20–16000 [Hz]	Frequency at which post-distortion filter 3 operates
Post3 Gain	-24.0–+24.0 [dB]	For the PKG type, the amount of boost/cut
Post3 Q	0.5–16.0	Width of the frequency range affected by the filter
Sense	-60.0–0.0 [dB]	Adjust this value so that the sound is not made louder when distortion is applied.
PostGain	-48.0–+12.0 [dB]	Gain following distortion processing
Balance	D100:0W–D0:100W	Volume balance between the dry sound (D) and effect sound (W)
Level	0–127	Output Level

32 W Saturator (Worm Saturator)

This is a variety of saturator, and is distinctive for its warmer sound.

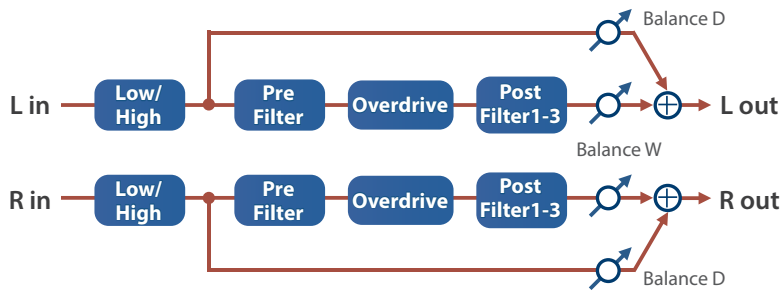

Parameter	Value	Explanation
LowFreq	20–16000 [Hz]	An input filter (low-band audio). Boosts/cuts the sound below the specified frequency.
LowGain	-24.0–+24.0 [dB]	An input filter (low-band audio). This is the boost/cut amount.
Hi Slope	THRU, -12dB, -24dB	The input filter (high frequency) slope (attenuation characteristics or amount of attenuation per octave). THRU: No attenuation -12 dB: Gentle -24 dB: Steep
Hi Freq	20–16000 [Hz]	An input filter (high-frequency audio). Boosts/cuts the sound above the specified frequency.
Pre1 Type	THRU, LPF, HPF, LSV, HSV	The types of filters available before distortion processing. THRU: No filter is applied LPF: A filter that passes the sound below the specified frequency HPF: A filter that passes the sound above the specified frequency LSV: A filter that boosts/cuts the sound below the specified frequency HSV: A filter that boosts/cuts the sound above the specified frequency
Pre1Freq	20–16000 [Hz]	Frequency at which the pre-distortion filter operates
Pre1Gain	-24.0–+24.0 [dB]	For the LSV/HSV types, the amount of boost/cut
Drive	0.0–48.0 [dB]	Strength of distortion
Post1 Type	THRU, LPF, HPF, LSV, HSV	Type of filter 1 which follows the distortion processing
Post1Frq	20–16000 [Hz]	Frequency at which post-distortion filter 1 operates
Post1Gain	-24.0–+24.0 [dB]	For the LSV/HSV types, the amount of boost/cut
Post2 Type	THRU, LPF, HPF, LSV, HSV	Type of filter 2 which follows the distortion processing
Post2Frq	20–16000 [Hz]	Frequency at which post-distortion filter 2 operates
Post2Gain	-24.0–+24.0 [dB]	For the LSV/HSV types, the amount of boost/cut
Post3 Type	THRU, LPF, HPF, BPF, PKG	The filter types available for filter 3 after distortion processing. THRU: No filter is applied LPF: A filter that passes the sound below the specified frequency HPF: A filter that passes the sound above the specified frequency BPF: A filter that passes only the specified frequency PKG: A filter that boosts/cuts the specified frequency
Post3Frq	20–16000 [Hz]	Frequency at which post-distortion filter 3 operates
Post3Gain	-24.0–+24.0 [dB]	For the PKG type, the amount of boost/cut
Post3 Q	0.5–16.0	Width of the frequency range affected by the filter

Parameter	Value	Explanation
Sense	-60.0–0.0 [dB]	Adjust this value so that the sound is not made louder when distortion is applied.
PostGain	-48.0–+12.0 [dB]	Gain following distortion processing
Balance	D100:0W–D0:100W	Volume balance between the dry sound (D) and effect sound (W)
Level	0–127	Output Level

33 Gt Amp Sim (Guitar Amp Simulator)

This is an effect that simulates the sound of a guitar amplifier.

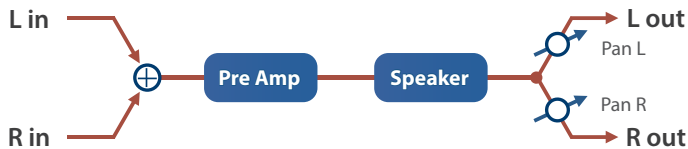

Parameter	Value	Explanation
Pre Amp Sw	OFF, ON	Turns the amp switch on/off.
ATyp	JC-120	This models the sound of the Roland JC-120.
	CLEAN TWIN	This models a Fender Twin Reverb.
	MATCH DRIVE	This models the sound input to left input on a Matchless D/C-30. A simulation of the latest tube amp widely used in styles from blues and rock.
	BG LEAD	This models the lead sound of the MESA/ Boogie combo amp. The sound of a tube amp typical of the late '70s to '80s.
	MS1959I	This models the sound input to Input I on a Marshall 1959. This is a trebly sound suited to hard rock.
	MS1959II	This models the sound input to Input II on a Marshall 1959.
	MS1959I+II	A model of the Marshall 1959 sound, with inputs I and II connected in parallel. Offers a sound with a more emphasized low-end than MS1959I.
	SLDN LEAD	This models a Soldano SLO-100. This is the typical sound of the eighties.
	METAL 5150	This models the lead channel of a Peavey EVH 5150.
	METAL LEAD	This is distortion sound that is ideal for performances of heavy riffs.
	OD-1	This models the sound of the BOSS OD-1. This produces sweet, mild distortion.
	OD-2 TURBO	This is the high-gain overdrive sound of the BOSS OD-2.
	DISTORTION	This gives a basic, traditional distortion sound.
FUZZ	A fuzz sound with rich harmonic content.	
Drive	0–127	Volume and amount of distortion of the amp
Master	0–127	Volume of the entire pre-amp
Gain	LOW, MIDDLE, HIGH	Amount of pre-amp distortion
Bass	0–127	
Middle	0–127	Tone of the bass/mid/treble frequency range
Treble	0–127	
Presence	0–127	Tone for the ultra-high frequency range
Bright	OFF, ON	Turning this "On" produces a sharper and brighter sound. This is enabled only when the preamp type is "JC-120", "CLEAN TWIN", "MATCH DRIVE" or "BG LEAD".

Parameter	Value	Explanation																																																																			
Speaker Sw	OFF, ON	Selects whether the sound will be sent through the speaker simulation (ON) or not (OFF)																																																																			
STyp		<table border="1"> <thead> <tr> <th>Cabinet</th> <th>Speaker diameter (in inches) and number of speakers</th> <th>Mic</th> </tr> </thead> <tbody> <tr> <td>SMALL 1</td> <td>small open-back enclosure</td> <td>10</td> <td>dynamic</td> </tr> <tr> <td>SMALL 2</td> <td>small open-back enclosure</td> <td>10</td> <td>dynamic</td> </tr> <tr> <td>MIDDLE</td> <td>open back enclosure</td> <td>12 x 1</td> <td>dynamic</td> </tr> <tr> <td>JC-120</td> <td>open back enclosure</td> <td>12 x 2</td> <td>dynamic</td> </tr> <tr> <td>BUILT-IN 1</td> <td>open back enclosure</td> <td>12 x 2</td> <td>dynamic</td> </tr> <tr> <td>BUILT-IN 2</td> <td>open back enclosure</td> <td>12 x 2</td> <td>condenser</td> </tr> <tr> <td>BUILT-IN 3</td> <td>open back enclosure</td> <td>12 x 2</td> <td>condenser</td> </tr> <tr> <td>BUILT-IN 4</td> <td>open back enclosure</td> <td>12 x 2</td> <td>condenser</td> </tr> <tr> <td>BUILT-IN 5</td> <td>open back enclosure</td> <td>12 x 2</td> <td>condenser</td> </tr> <tr> <td>BG STACK 1</td> <td>sealed enclosure</td> <td>12 x 2</td> <td>condenser</td> </tr> <tr> <td>BG STACK 2</td> <td>large sealed enclosure</td> <td>12 x 2</td> <td>condenser</td> </tr> <tr> <td>MS STACK 1</td> <td>large sealed enclosure</td> <td>12 x 4</td> <td>condenser</td> </tr> <tr> <td>MS STACK 2</td> <td>large sealed enclosure</td> <td>12 x 4</td> <td>condenser</td> </tr> <tr> <td>METAL STACK</td> <td>large double stack</td> <td>12 x 4</td> <td>condenser</td> </tr> <tr> <td>2-STACK</td> <td>large double stack</td> <td>12 x 4</td> <td>condenser</td> </tr> <tr> <td>3-STACK</td> <td>large triple stack</td> <td>12 x 4</td> <td>condenser</td> </tr> </tbody> </table>	Cabinet	Speaker diameter (in inches) and number of speakers	Mic	SMALL 1	small open-back enclosure	10	dynamic	SMALL 2	small open-back enclosure	10	dynamic	MIDDLE	open back enclosure	12 x 1	dynamic	JC-120	open back enclosure	12 x 2	dynamic	BUILT-IN 1	open back enclosure	12 x 2	dynamic	BUILT-IN 2	open back enclosure	12 x 2	condenser	BUILT-IN 3	open back enclosure	12 x 2	condenser	BUILT-IN 4	open back enclosure	12 x 2	condenser	BUILT-IN 5	open back enclosure	12 x 2	condenser	BG STACK 1	sealed enclosure	12 x 2	condenser	BG STACK 2	large sealed enclosure	12 x 2	condenser	MS STACK 1	large sealed enclosure	12 x 4	condenser	MS STACK 2	large sealed enclosure	12 x 4	condenser	METAL STACK	large double stack	12 x 4	condenser	2-STACK	large double stack	12 x 4	condenser	3-STACK	large triple stack	12 x 4	condenser
	Cabinet	Speaker diameter (in inches) and number of speakers	Mic																																																																		
	SMALL 1	small open-back enclosure	10	dynamic																																																																	
	SMALL 2	small open-back enclosure	10	dynamic																																																																	
	MIDDLE	open back enclosure	12 x 1	dynamic																																																																	
	JC-120	open back enclosure	12 x 2	dynamic																																																																	
	BUILT-IN 1	open back enclosure	12 x 2	dynamic																																																																	
	BUILT-IN 2	open back enclosure	12 x 2	condenser																																																																	
	BUILT-IN 3	open back enclosure	12 x 2	condenser																																																																	
	BUILT-IN 4	open back enclosure	12 x 2	condenser																																																																	
	BUILT-IN 5	open back enclosure	12 x 2	condenser																																																																	
	BG STACK 1	sealed enclosure	12 x 2	condenser																																																																	
	BG STACK 2	large sealed enclosure	12 x 2	condenser																																																																	
	MS STACK 1	large sealed enclosure	12 x 4	condenser																																																																	
	MS STACK 2	large sealed enclosure	12 x 4	condenser																																																																	
METAL STACK	large double stack	12 x 4	condenser																																																																		
2-STACK	large double stack	12 x 4	condenser																																																																		
3-STACK	large triple stack	12 x 4	condenser																																																																		
Mic Setting	1–3	The position of the mic that picks up the speaker sound. This can be adjusted in three steps, with the microphone becoming more distant in the order of 1, 2, and 3.																																																																			
Mic Level	0–127	Volume of the microphone																																																																			
Direct Level	0–127	Volume of the direct sound																																																																			
Pan	L64–63R	Stereo location of the output sound																																																																			
Level	0–127	Output Level																																																																			

34 EP Amp Sim (RD EP Amp Simulator)

This is an effect that was developed for the RD series SuperNATURAL E.Piano.

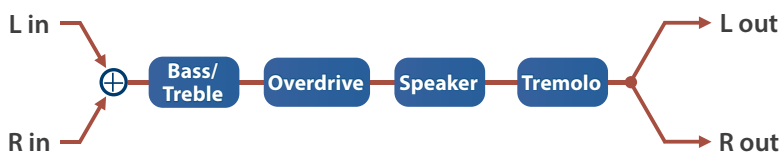

Parameter	Value	Explanation
Bass	-50–+50	Amount of low-frequency boost/cut
Treble	-50–+50	Amount of high-frequency boost/cut
Tremolo Sw	OFF, ON	Tremolo on/off
Type	OLDCASE MO	A standard electric piano sound of the early 70s (mono)
	OLDCASE ST	A standard electric piano sound of the early 70s (stereo)
	NEWCASE	A standard electric piano sound of the late 70s and early 80s
	DYNO	A classic modified electric piano
	WURLY	A classic electric piano of the '60s
Speed Sync	OFF, ON	If this is ON, the rate synchronizes with the tempo of the rhythm.
Speed	0.05–10.00 [Hz]	Rate of the tremolo effect

Parameter	Value	Explanation
Speed Nt	Note	1/64T, 1/64, 1/32T, 1/32, 1/16T, 1/32., 1/16, 1/8T, 1/16., 1/8, 1/4T, 1/8., 1/4, 1/2T, 1/4., 1/2, 1T, 1/2., 1, 2T, 1., 2
Depth	0–127	Depth of the tremolo effect
Shape	0–20	Adjusts the waveform of the tremolo.
AMP	OFF, ON	Turns the speaker and distortion on/off
Speaker	LINE, OLD, NEW, WURLY, TWIN	Type of speaker. If LINE is selected, the sound will not be sent through the speaker simulation.
Drive	0–127	Degree of distortion Also changes the volume.
Level	0–127	Output Level

35 Speaker Sim (Speaker Simulator)

Simulates the speaker type and mic settings used to record the speaker sound.

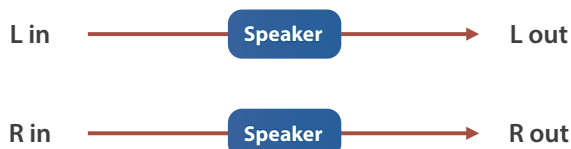

Parameter	Value	Explanation		
Type		Cabinet		
		Speaker diameter (in inches) and number of speakers		
		Mic		
	SMALL 1	small open-back enclosure	10	dynamic
	SMALL 2	small open-back enclosure	10	dynamic
	MIDDLE	open back enclosure	12 x 1	dynamic
	JC-120	open back enclosure	12 x 2	dynamic
	BUILT-IN 1	open back enclosure	12 x 2	dynamic
	BUILT-IN 2	open back enclosure	12 x 2	condenser
	BUILT-IN 3	open back enclosure	12 x 2	condenser
	BUILT-IN 4	open back enclosure	12 x 2	condenser
	BUILT-IN 5	open back enclosure	12 x 2	condenser
	BG STACK 1	sealed enclosure	12 x 2	condenser
	BG STACK 2	large sealed enclosure	12 x 2	condenser
	MS STACK 1	large sealed enclosure	12 x 4	condenser
MS STACK 2	large sealed enclosure	12 x 4	condenser	
METAL STACK	large double stack	12 x 4	condenser	
2-STACK	large double stack	12 x 4	condenser	
3-STACK	large triple stack	12 x 4	condenser	
Mic Setting	1–3	The position of the mic that picks up the speaker sound. This can be adjusted in three steps, with the microphone becoming more distant in the order of 1, 2, and 3.		
Mic Level	0–127	Volume of the microphone		
Direct Lv	0–127	Volume of the direct sound		
Level	0–127	Output Level		

Comp / Limiter

36 Compressor

Flattens out high levels and boosts low levels, smoothing out fluctuations in volume.

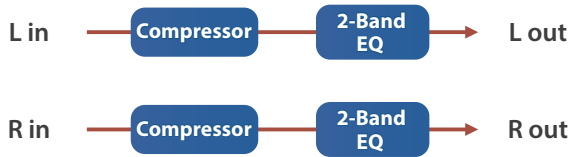

Parameter	Value	Explanation
Attack	0–124	Sets the speed at which compression starts
Release	0–124	Adjusts the time after the signal volume falls below the Threshold Level until compression is no longer applied.
Threshold	-60–0 [dB]	Adjusts the volume at which compression begins
Knee	0–30 [dB]	This smooths out the sonic transition, from when the compression is not engaged until when the compression begins. This gradually applies compression from just before the Threshold point. Higher values produce a smoother transition.
Ratio	1:1, 1.5:1, 2:1, 4:1, 16:1, INF:1	Compression ratio
Post Gain	0–+18 [dB]	Level of the output sound
Level	0–127	Output Level

37 Limiter

Compresses signals that exceed a specified volume level, preventing distortion from occurring.

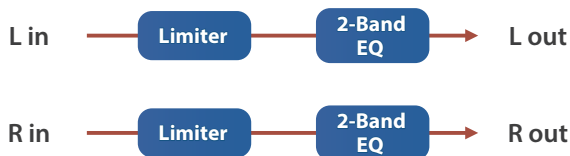

Parameter	Value	Explanation
Release	0–127	Adjusts the time after the signal volume falls below the Threshold Level until compression is no longer applied.
Threshold	0–127	Adjusts the volume at which compression begins
Ratio	1.5:1, 2:1, 4:1, 100:1	Compression ratio
Post Gain	0–+18 [dB]	Level of the output sound
Low Gain	-15–+15 [dB]	Amount of boost/cut for the low-frequency range
High Gain	-15–+15 [dB]	Amount of boost/cut for the high-frequency range
Level	0–127	Output Level

38 Sustainer

By compressing loud input and boosting low input, this effect keeps the volume consistent to produce a sustain effect without distortion.

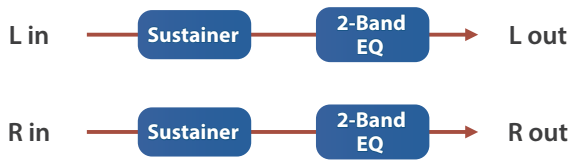

Parameter	Value	Explanation
Sustain	0–127	Adjusts the range in which a low input signal is boosted to a consistent volume. Higher values produce longer sustain.
Attack	0–127	Time until the volume is compressed
Release	0–127	Time until compression is removed
Post Gain	-15–+15 [dB]	Level of the output sound
Low Gain	-15–+15 [dB]	Amount of boost/cut for the low-frequency range
High Gain	-15–+15 [dB]	Amount of boost/cut for the high-frequency range
Level	0–127	Output Level

39 Transient

This effect lets you control the way in which the sound attacks and decays.

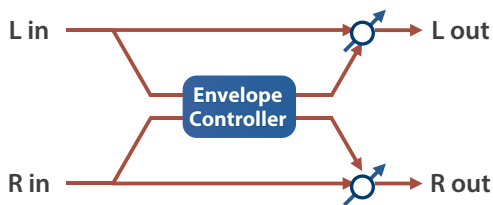

Parameter	Value	Explanation
Attack	-50–+50	Character of the attack. Higher values make the attack more aggressive; lower values make the attack milder.
Release	-50–+50	Character of the decay. Higher values make the sound linger; lower values make the sound cutoff quickly.
Out Gain	-24–+12 [dB]	Output gain
Sens	LOW, MID, HIGH	Quickness with which the attack is detected
Level	0–127	Output Level

Delay

40 Delay

This is a stereo delay.

When Feedback Mode is NORMAL:

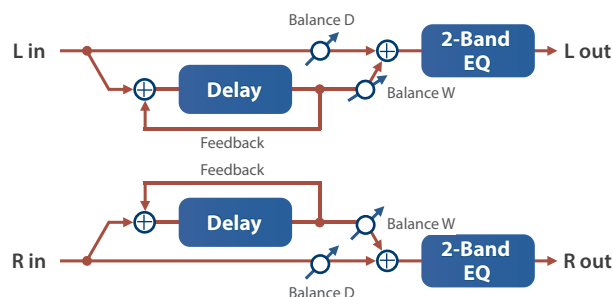

When Feedback Mode is CROSS:

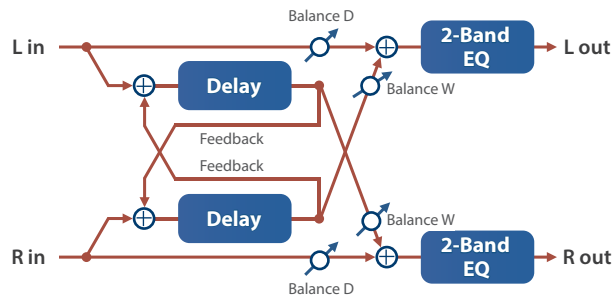

Parameter	Value	Explanation
Dly L Sync	OFF, ON	If this is ON, the rate synchronizes with the tempo of the rhythm.
DL.Time	1–1300	Adjusts the time until the left delay sound is heard.
DLTime Nt	Note	1/64T, 1/64, 1/32T, 1/32, 1/16T, 1/32., 1/16, 1/8T, 1/16., 1/8, 1/4T, 1/8., 1/4, 1/2T, 1/4., 1/2, 1T, 1/2., 1, 2T, 1., 2
Dly R Sync	OFF, ON	If this is ON, the rate synchronizes with the tempo of the rhythm.
DR.Time	1–1300	Adjusts the time until the right delay sound is heard.
DRTIME Nt	Note	1/64T, 1/64, 1/32T, 1/32, 1/16T, 1/32., 1/16, 1/8T, 1/16., 1/8, 1/4T, 1/8., 1/4, 1/2T, 1/4., 1/2, 1T, 1/2., 1, 2T, 1., 2
Phase L	NORMAL, INVERSE	Phase of the left-right delay sound.
Phase R	NORMAL, INVERSE	NORMAL: Non-inverted INVERSE: Inverted
Fbk Mode	NORMAL, CROSS	Selects the way in which delay sound is fed back into the effect (See the figures above).
Feedback	-98–+98 [%]	Adjusts the proportion of the delay sound that is fed back into the effect (Negative values invert the phase).
HF Damp	Adjusts the frequency above which sound fed back to the effect is filtered out. If you don't want to filter out any high frequencies, set this parameter to BYPASS . 200, 250, 315, 400, 500, 630, 800, 1000, 1250, 1600, 2000, 2500, 3150, 4000, 5000, 6300, 8000, BYPASS [Hz]	
Low Gain	-15–+15 [dB]	Amount of boost/cut for the low-frequency range
High Gain	-15–+15 [dB]	Amount of boost/cut for the high-frequency range
Balance	D100:0W–D0:100W	Volume balance between the direct sound (D) and the delay sound (W)
Level	0–127	Output Level

41 Mod Delay (Modulation Delay)

Adds modulation to the delayed sound.

When Feedback Mode is NORMAL:

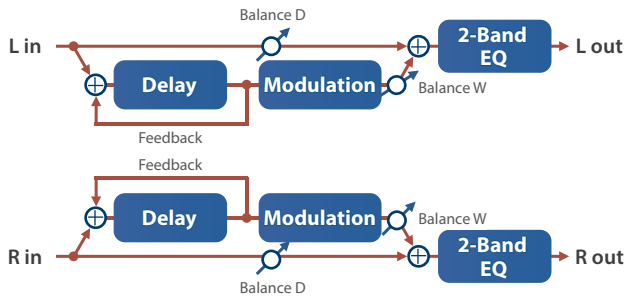

When Feedback Mode is CROSS:

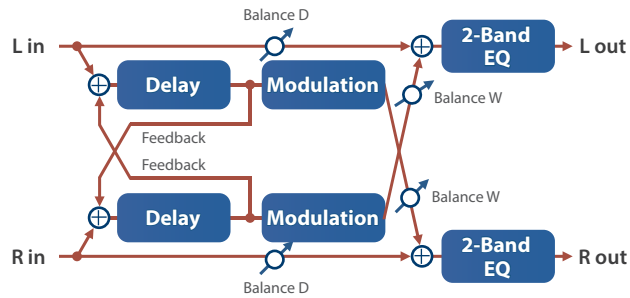

Parameter	Value	Explanation
Dly L Sync	OFF, ON	If this is ON, the rate synchronizes with the tempo of the rhythm.
DL.Time	1–1300	Adjusts the time until the left delay sound is heard.
DLTime Nt	Note	1/64T, 1/64, 1/32T, 1/32, 1/16T, 1/32., 1/16, 1/8T, 1/16., 1/8, 1/4T, 1/8., 1/4, 1/2T, 1/4., 1/2, 1T, 1/2., 1, 2T, 1., 2
Dly R Sync	OFF, ON	If this is ON, the rate synchronizes with the tempo of the rhythm.
DR.Time	1–1300	Adjusts the time until the right delay sound is heard.
DRTIME Nt	Note	1/64T, 1/64, 1/32T, 1/32, 1/16T, 1/32., 1/16, 1/8T, 1/16., 1/8, 1/4T, 1/8., 1/4, 1/2T, 1/4., 1/2, 1T, 1/2., 1, 2T, 1., 2
Fbk Mode	NORMAL, CROSS	Selects the way in which delay sound is fed back into the effect (See the figures above).
Feedback	-98--+98 [%]	Adjusts the proportion of the delay sound that is fed back into the effect (Negative values invert the phase).
HF Damp	Adjusts the frequency above which sound fed back to the effect is filtered out. If you don't want to filter out any high frequencies, set this parameter to BYPASS . 200, 250, 315, 400, 500, 630, 800, 1000, 1250, 1600, 2000, 2500, 3150, 4000, 5000, 6300, 8000, BYPASS [Hz]	
Rate Sync	OFF, ON	If this is ON, the rate synchronizes with the tempo of the rhythm.
Rate	0.05–10.00 [Hz]	Frequency of modulation
Rate Note	Note	1/64T, 1/64, 1/32T, 1/32, 1/16T, 1/32., 1/16, 1/8T, 1/16., 1/8, 1/4T, 1/8., 1/4, 1/2T, 1/4., 1/2, 1T, 1/2., 1, 2T, 1., 2
Depth	0–127	Depth of modulation
Phase	0–180 [deg]	Spatial spread of the sound
Low Gain	-15--+15 [dB]	Amount of boost/cut for the low-frequency range
High Gain	-15--+15 [dB]	Amount of boost/cut for the high-frequency range
Balance	D100:0W–D0:100W	Volume balance between the direct sound (D) and the delay sound (W)
Level	0–127	Output Level

42 2Tap PanDly (2 Tap Pan Delay)

The delay sound is heard both at the left and at the right.

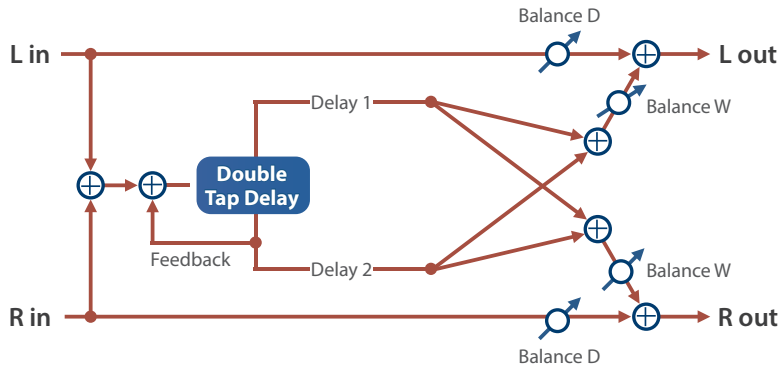

Parameter	Value	Explanation
Delay Sync	OFF, ON	If this is ON, the delay synchronizes with the tempo.
Time (ms)	1–2600	Adjusts the time until the second delay sound is heard.
D.Time (Nt)	Note	1/64T, 1/64, 1/32T, 1/32, 1/16T, 1/32., 1/16, 1/8T, 1/16., 1/8, 1/4T, 1/8., 1/4, 1/2T, 1/4., 1/2, 1T, 1/2., 1, 2T, 1., 2
Delay Fbk	-98+98 [%]	Adjusts the proportion of the delay sound that is fed back into the effect (Negative values invert the phase).
Dly HF	Adjusts the frequency above which sound fed back to the effect is filtered out. If you don't want to filter out any high frequencies, set this parameter to BYPASS . 200, 250, 315, 400, 500, 630, 800, 1000, 1250, 1600, 2000, 2500, 3150, 4000, 5000, 6300, 8000, BYPASS [Hz]	
Dly1 Pan	L64–63R	Adjusts the stereo location of delay 1.
Dly2 Pan	L64–63R	Adjusts the stereo location of delay 2.
Dly1 Lv	0–127	Adjusts the volume of delay 1.
Dly2 Lv	0–127	Adjusts the volume of delay 2.
Low Gain	-15+15 [dB]	Amount of boost/cut for the low-frequency range
High Gain	-15+15 [dB]	Amount of boost/cut for the high-frequency range
Balance	D100:0W–D0:100W	Adjusts the volume balance between the sound that is sent through the delay (W) and the sound that is not sent through the delay (D).
Level	0–127	Output Level

43 3Tap PanDly (3 Tap Pan Delay)

Produces three delay sounds; center, left and right.

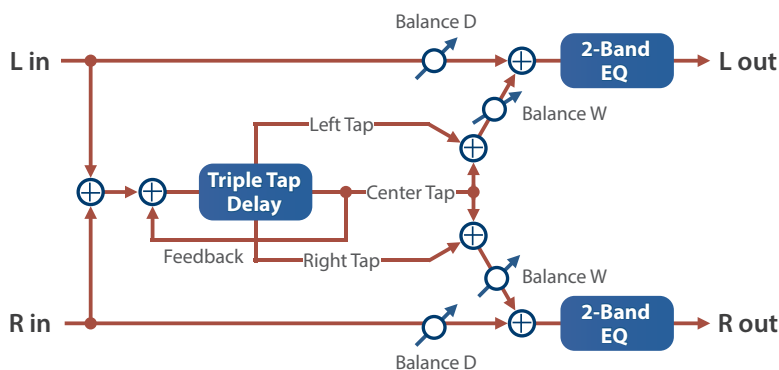

Parameter	Value	Explanation
Dly L Sync	OFF, ON	If this is ON, the rate synchronizes with the tempo of the rhythm.
DL.Time	1–2600	Adjusts the time until the left delay sound is heard.

Parameter	Value	Explanation
DLTime Nt	Note	1/64T, 1/64, 1/32T, 1/32, 1/16T, 1/32., 1/16, 1/8T, 1/16., 1/8, 1/4T, 1/8., 1/4, 1/2T, 1/4., 1/2, 1T, 1/2., 1, 2T, 1., 2
Dly R Sync	OFF, ON	If this is ON, the rate synchronizes with the tempo of the rhythm.
DR.Time	1–2600	Adjusts the time until the right delay sound is heard.
DRTIME Nt	Note	1/64T, 1/64, 1/32T, 1/32, 1/16T, 1/32., 1/16, 1/8T, 1/16., 1/8, 1/4T, 1/8., 1/4, 1/2T, 1/4., 1/2, 1T, 1/2., 1, 2T, 1., 2
Dly C Sync	OFF, ON	If this is ON, the rate synchronizes with the tempo of the rhythm.
DC.Time	1–2600	Adjusts the time until the center delay sound is heard.
DCTIME Nt	Note	1/64T, 1/64, 1/32T, 1/32, 1/16T, 1/32., 1/16, 1/8T, 1/16., 1/8, 1/4T, 1/8., 1/4, 1/2T, 1/4., 1/2, 1T, 1/2., 1, 2T, 1., 2
C Feedback	-98–+98 [%]	Adjusts the proportion of the delay sound that is fed back into the effect (Negative values invert the phase).
HF Damp	Adjusts the frequency above which sound fed back to the effect is filtered out. If you don't want to filter out any high frequencies, set this parameter to BYPASS . 200, 250, 315, 400, 500, 630, 800, 1000, 1250, 1600, 2000, 2500, 3150, 4000, 5000, 6300, 8000, BYPASS [Hz]	
Left Lv	0–127	
Right Lv	0–127	Volume of each delay sound
Center Lv	0–127	
Low Gain	-15–+15 [dB]	Amount of boost/cut for the low-frequency range
High Gain	-15–+15 [dB]	Amount of boost/cut for the high-frequency range
Balance	D100:0W–D0:100W	Volume balance between the direct sound (D) and the delay sound (W)
Level	0–127	Output Level

44 Reverse Dly (Reverse Delay)

This is a reverse delay that adds a reversed and delayed sound to the input sound. A tap delay is connected immediately after the reverse delay.

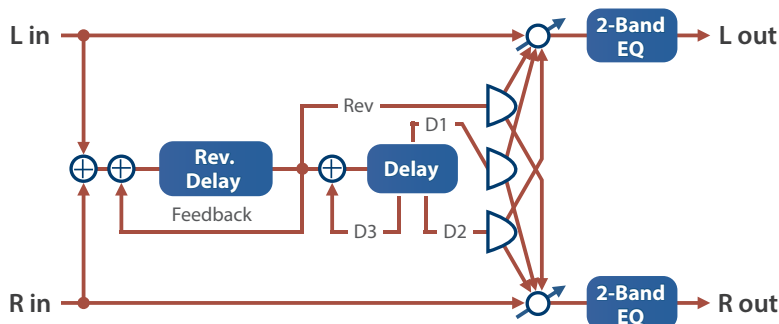

Parameter	Value	Explanation
Threshold	0–127	Volume at which the reverse delay will begin to be applied
RDly Sync	OFF, ON	If this is ON, the rate synchronizes with the tempo of the rhythm.
RD.Time	1–1300	Delay time from when sound is input into the reverse delay until the delay sound is heard
RD.Time Nt	Note	1/64T, 1/64, 1/32T, 1/32, 1/16T, 1/32., 1/16, 1/8T, 1/16., 1/8, 1/4T, 1/8., 1/4, 1/2T, 1/4., 1/2, 1T, 1/2., 1, 2T, 1., 2
RDly Fbk	-98–+98 [%]	Proportion of the delay sound that is to be returned to the input of the reverse delay negative (-) values invert the phase)

Parameter	Value	Explanation
RDly HF	Frequency at which the high-frequency content of the reverse-delayed sound will be cut (BYPASS : no cut)	
	200, 250, 315, 400, 500, 630, 800, 1000, 1250, 1600, 2000, 2500, 3150, 4000, 5000, 6300, 8000, BYPASS [Hz]	
RDly Pan	L64–63R	Panning of the reverse delay sound
RDly Level	0–127	Volume of the reverse delay sound
Dly1 Sync	OFF, ON	If this is ON, the rate synchronizes with the tempo of the rhythm.
D1.Time	1–1300	Delay time from when sound is input into the tap delay until the delay sound is heard
D1Time Nt	Note	1/64T, 1/64, 1/32T, 1/32, 1/16T, 1/32., 1/16, 1/8T, 1/16., 1/8, 1/4T, 1/8., 1/4, 1/2T, 1/4., 1/2, 1T, 1/2., 1, 2T, 1., 2
Dly2 Sync	OFF, ON	If this is ON, the rate synchronizes with the tempo of the rhythm.
D2.Time	1–1300	Delay time from when sound is input into the tap delay until the delay sound is heard
D2Time Nt	Note	1/64T, 1/64, 1/32T, 1/32, 1/16T, 1/32., 1/16, 1/8T, 1/16., 1/8, 1/4T, 1/8., 1/4, 1/2T, 1/4., 1/2, 1T, 1/2., 1, 2T, 1., 2
Dly3 Sync	OFF, ON	If this is ON, the rate synchronizes with the tempo of the rhythm.
D3.Time	1–1300	Delay time from when sound is input into the tap delay until the delay sound is heard
D3Time Nt	Note	1/64T, 1/64, 1/32T, 1/32, 1/16T, 1/32., 1/16, 1/8T, 1/16., 1/8, 1/4T, 1/8., 1/4, 1/2T, 1/4., 1/2, 1T, 1/2., 1, 2T, 1., 2
Dly3 Fbk	-98–+98 [%]	Proportion of the delay sound that is to be returned to the input of the tap delay (Negative values invert the phase).
Dly HF	Frequency at which the hi-frequency content of the tap delay sound will be cut (BYPASS : no cut)	
	200, 250, 315, 400, 500, 630, 800, 1000, 1250, 1600, 2000, 2500, 3150, 4000, 5000, 6300, 8000, BYPASS [Hz]	
Dly1 Pan	L64–63R	Panning of the tap delay sounds
Dly2 Pan	L64–63R	
Dly1 Lv	0–127	Volume of the tap delay sounds
Dly2 Lv	0–127	
Low Gain	-15–+15 [dB]	Amount of boost/cut for the low-frequency range
High Gain	-15–+15 [dB]	Amount of boost/cut for the high-frequency range
Balance	D100:0W–D0:100W	Volume balance between the direct sound (D) and the delay sound (W)
Level	0–127	Output Level

45 Tape Echo

A virtual tape echo that produces a realistic tape delay sound. This simulates the tape echo section of a Roland RE-201 Space Echo.

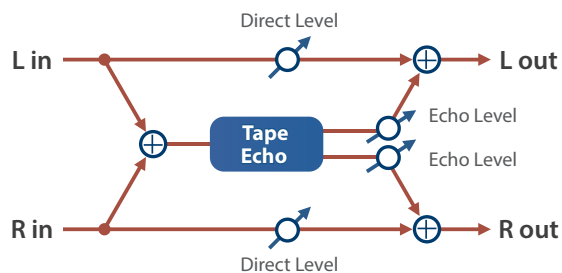

Parameter	Value	Explanation
Mode	S, M, L, S+M, S+L, M+L, S+M+L	Combination of playback heads to use. Select from three different heads with different delay times. S: short M: middle L: long
Repeat Rate	0–127	Tape speed. Increasing this value will shorten the spacing of the delayed sounds.
Intensity	0–127	Amount of delay repeats
Bass	-15–+15 [dB]	Boost/cut for the lower range of the echo sound
Treble	-15–+15 [dB]	Boost/cut for the upper range of the echo sound
Head S Pan	L64–63R	Independent panning for the short, middle, and long playback heads
Head M Pan	L64–63R	
Head L Pan	L64–63R	
Distortion	0–5	Amount of tape-dependent distortion to be added. This simulates the slight tonal changes that can be detected by signal-analysis equipment. Increasing this value will increase the distortion.
Wf Rate	0–127	Speed of wow/flutter (complex variation in pitch caused by tape wear and rotational irregularity)
Wf Depth	0–127	Depth of wow/flutter
Echo Level	0–127	Volume of the echo sound
Direct Lv	0–127	Volume of the original sound
Level	0–127	Output Level

Looper

46 DJFX Looper

Loops a short portion of the input sound. You can vary the playback direction and playback speed of the input sound to add turntable-type effects.

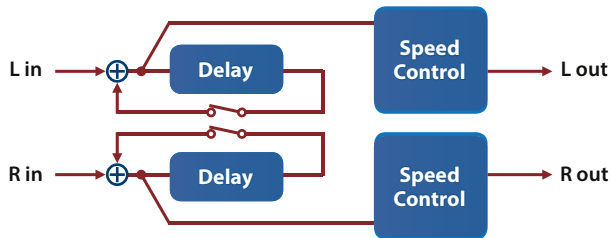

Parameter	Value	Explanation
Length	230–12 (not straight)	Length of the loop
Speed	-1.00–+1.00	Playback direction and playback speed. - direction: Reverse playback + direction: Normal playback 0: Stop playback As the value moves away from 0, the playback speed becomes faster.
Loop Sw	OFF, ON	If you turn this on while the sound is heard, the sound at that point will be looped. Turn this off to cancel the loop. If the effect is recalled with this ON, this parameter must be turned OFF and then turned ON again in order to make the loop operate.
Level	0–127	Output Level

47 BPM Looper

Loops a short portion of the input sound. This can automatically turn the loop on/off in synchronization with the rhythm.

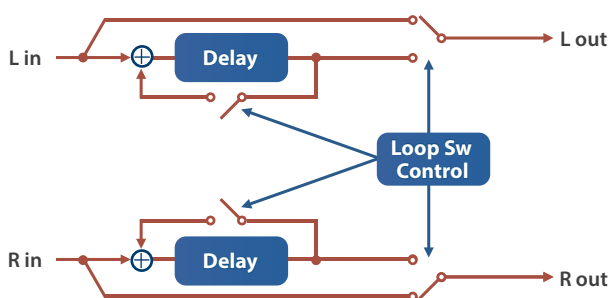

Parameter	Value	Explanation
Length	230–12 (not straight)	Specifies the length of the loop.
Rate Sync	OFF, ON	If this is ON, the rate synchronizes with the tempo of the rhythm.
Rate	0.05–10.00 [Hz]	Cycle at which the loop automatically turns on/off
Rate Note	Note	1/64T, 1/64, 1/32T, 1/32, 1/16T, 1/32., 1/16, 1/8T, 1/16., 1/8, 1/4T, 1/8., 1/4, 1/2T, 1/4., 1/2, 1T, 1/2., 1, 2T, 1., 2
Timing	1–8	Specifies the timing within the cycle at which the loop automatically starts (which step of the eight timing divisions at which the sound is heard)
Lenth	1–8	Specifies the length at which the loop automatically ends within the cycle (the number of times that the 1/8-length of sound is heard)

Parameter	Value	Explanation
Loop Mode	OFF, AUTO, ON	If this is AUTO, the loop automatically turns on/off in synchronization with the rhythm. If the effect is recalled with this ON, this parameter must first be set to something other than ON in order to make the loop operate.
Level	0–127	Output Level

Lo-fi

48 LOFI Comp (Lo-Fi Compressor)

Degrades the sound quality.

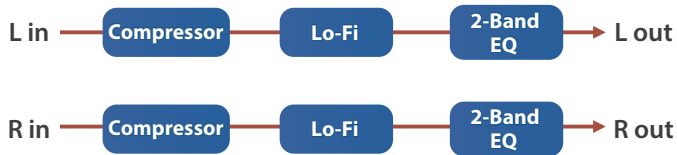

Parameter	Value	Explanation
Pre Filter	1–6	Selects the type of filter applied to the sound before it passes through the Lo-Fi effect. 1: Compressor off 2–6: Compressor on
LoFi Type	1–9	Degrades the sound quality. The sound quality grows poorer as this value is increased.
Post Filter	OFF, LPF, HPF	Selects the type of filter applied to the sound after it passes through the Lo-Fi effect. OFF: No filter is used LPF: Cuts the frequency range above the Cutoff Freq HPF: Cuts the frequency range below the Cutoff Freq
Cutoff	200–8000 [Hz]	Basic frequency of the Post Filter
Low Gain	-15–+15 [dB]	Amount of boost/cut for the low-frequency range
High Gain	-15–+15 [dB]	Amount of boost/cut for the high-frequency range
Balance	D100:0W–D0:100W	Volume balance between the direct sound (D) and the effect sound (W)
Level	0–127	Output Level

49 Bit Crusher

Produces an extreme lo-fi effect.

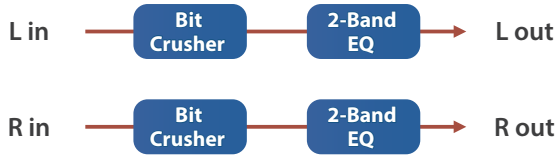

Parameter	Value	Explanation
Sample Rate	0–127	Adjusts the sample rate.
Bit Down	0–20	Adjusts the bit depth.
Filter	0–127	Adjusts the filter depth.
Low Gain	-15–+15 [dB]	Amount of boost/cut for the low-frequency range
High Gain	-15–+15 [dB]	Amount of boost/cut for the high-frequency range
Level	0–127	Output Level

50 Phonograph

Recreates the sound of an analog record being played on a record player. This lets you simulate the unique noises produced when a record is played, as well as the variations that occur when the record spins.

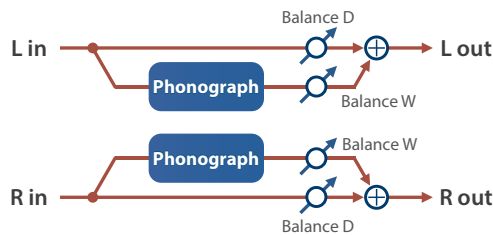

Parameter	Value	Explanation
Signal Dist	0–127	Sets the amount of distortion.
Frequency Range	0–127	Sets the frequency characteristics of the playback system. Smaller values create the feeling of an older system with narrow frequency bands.
Disc Type	LP, EP, SP	Sets the turntable rotation speed. This has an effect on the scratch noise cycle.
Scratch NZ Lev	0–127	Sets the volume of noise created by scratches in the record.
Dust NZ Lev	0–127	Sets the volume of noise created by dust on the record.
Hiss NZ Lev	0–127	Sets the volume of continuous hiss noise.
Total NZ Lev	0–127	Sets the volume of noise overall.
Wow	0–127	Sets the amount of variation in record spin (long cycle).
Flutter	0–127	Sets the amount of variation in record spin (short cycle).
Random	0–127	Sets the amount of non-cyclical variation in record spin.
Total W/F	0–127	Sets the volume of variation in record spin overall.
Balance	D100:0W–D0:100W	Sets the volume balance between the original sound (D) and the effect sound (W).
Level	0–127	Sets the output volume.

Pitch

51 PitchShiftr (Pitch Shifter)

A stereo pitch shifter.

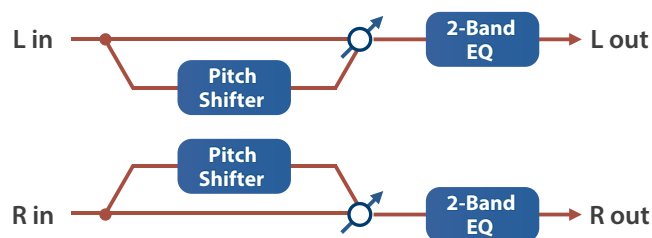

Parameter	Value	Explanation
Coarse	-24--+12 [sem]	Adjusts the pitch of the pitch shifted sound in semitone steps.
Fine	-100--+100	Adjusts the pitch of the pitch shifted sound in 2-cent steps.
Delay Sync	OFF, ON	If this is ON, the rate synchronizes with the tempo of the rhythm.
D.Time	1-1300	Adjusts the delay time from the direct sound until the pitch shifted sound is heard.
D.Time Nt	Note	1/64T, 1/64, 1/32T, 1/32, 1/16T, 1/32., 1/16, 1/8T, 1/16., 1/8, 1/4T, 1/8., 1/4, 1/2T, 1/4., 1/2, 1T, 1/2., 1, 2T, 1., 2
Feedback	-98--+98 [%]	Adjusts the proportion of the pitch shifted sound that is fed back into the effect (Negative values invert the phase).
Low Gain	-15--+15 [dB]	Amount of boost/cut for the low-frequency range
High Gain	-15--+15 [dB]	Amount of boost/cut for the high-frequency range
Balance	D100:0W-D0:100W	Volume balance between the direct sound (D) and the pitch shifted sound (W)
Level	0-127	Output Level

52 2V PShifter (2 Voice Pitch Shifter)

Shifts the pitch of the original sound. This 2-voice pitch shifter has two pitch shifters, and can add two pitch shifted sounds to the original sound.

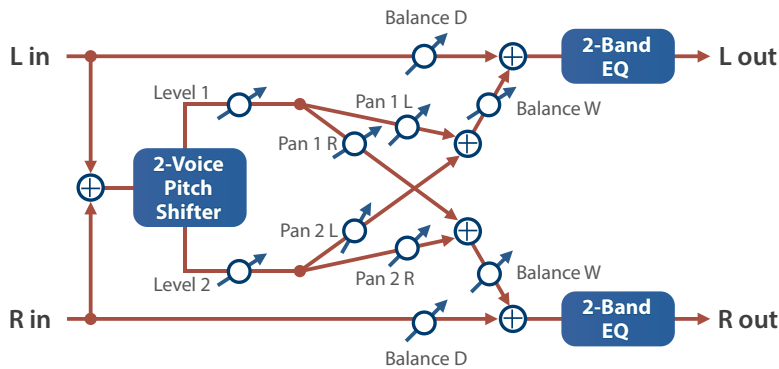

Parameter	Value	Explanation
P1Coarse	-24--+12 [sem]	Adjusts the pitch of Pitch Shift 1 in semitone steps.
P1 Fine	-100--+100	Adjusts the pitch of Pitch Shift Pitch 1 in 2-cent steps.
P1 Dly Sync	OFF, ON	If this is ON, the rate synchronizes with the tempo of the rhythm.
P1D.Time	1-1300	Adjusts the delay time from the direct sound until the Pitch Shift 1 sound is heard.
P1DRate Nt	Note	1/64T, 1/64, 1/32T, 1/32, 1/16T, 1/32., 1/16, 1/8T, 1/16., 1/8, 1/4T, 1/8., 1/4, 1/2T, 1/4., 1/2, 1T, 1/2., 1, 2T, 1., 2
P1 Feedback	-98--+98 [%]	Adjusts the proportion of the pitch shifted sound that is fed back into the effect (Negative values invert the phase).
P1 Pan	L64-63R	Stereo location of the Pitch Shift 1 sound
P1 Level	0-127	Volume of the Pitch Shift 1 sound
P2Coarse	-24--+12 [sem]	
P2 Fine	-100--+100	
P2 Dly Sync	OFF, ON	
P2D.Time	1-1300	Settings of the Pitch Shift 2 sound.
P2DRate Nt	Note	The parameters are the same as for the Pitch Shift 1 sound.
P2 Feedback	-98--+98 [%]	
P2 Pan	L64-63R	
P2 Level	0-127	
Low Gain	-15--+15 [dB]	Amount of boost/cut for the low-frequency range
High Gain	-15--+15 [dB]	Amount of boost/cut for the high-frequency range
Balance	D100:0W-D0:100W	Volume balance between the direct sound (D) and the pitch shifted sound (W)
Level	0-127	Output Level

Combination

53 JD Multi

Recreates the effects included in group A of the JD-800.

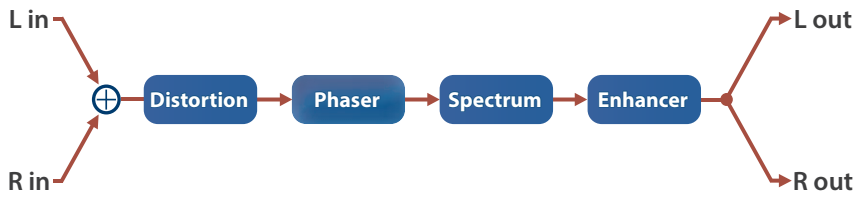

Parameter	Value	Explanation
Seq	DS - PH - SP - EN	Selects the connection order of the effects. DS: Distortion PH: Phaser SP: Spectrum EN: Enhancer
	DS - PH - EN - SP	
	DS - SP - PH - EN	
	DS - SP - EN - PH	
	DS - EN - PH - SP	
	DS - EN - SP - PH	
	PH - DS - SP - EN	
	PH - DS - EN - SP	
	PH - SP - DS - EN	
	PH - SP - EN - DS	
	PH - EN - DS - SP	
	PH - EN - SP - DS	
	SP - DS - PH - EN	
	SP - DS - EN - PH	
	SP - PH - DS - EN	
	SP - PH - EN - DS	
	SP - EN - DS - PH	
	SP - EN - PH - DS	
	EN - DS - PH - SP	
	EN - DS - SP - PH	
EN - PH - DS - SP		
EN - PH - SP - DS		
EN - SP - DS - PH		
EN - SP - PH - DS		
DS Switch	OFF, ON	Turns the distortion on/off.
DS Type	Sets the type of distortion.	
	MELLOW DRV	Softer distortion with a slightly darker sound.
	OVERDRIVE	Distortion that resembles a vacuum tube amp being driven.
	CRY DRV	Distortion that emphasizes the high end.
	MELLOW DST	Gives the feeling of distortion playing through a large amp.
	LIGHT DST	Strong distortion with a bright sound.
	FAT DIST	Thick distortion that emphasizes the low and high ends.
FUZZ DIST	Distortion that's even more powerful than FAT DIST.	
DS Drive	0-100	Sets the amount of distortion.
DS Level	0-100	Sets the distortion output level.

Parameter	Value	Explanation
PH Switch	OFF, ON	Turns the phaser on/off.
PH Manual	50 [Hz]–15.0 [kHz]	Sets the basic frequency from which the sound is modulated with the phaser effect.
PH Rate	0.1–10.0 [Hz]	Sets the cycle of the phaser modulation.
PH Depth	0–100	Sets the depth of the phaser modulation.
PH Resonance	0–100	Sets the amount of feedback for the phaser. Increasing the value creates a more unusual sound.
PH Mix	0–100	Sets the level of the phase-shifted sound.
SP Switch	OFF, ON	Turns the spectrum on/off.
SP Band Ctrl1	-15–+15 [dB]	Sets the gain (amount of boost/cut) in the 250 Hz range.
SP Band Ctrl2	-15–+15 [dB]	Sets the gain (amount of boost/cut) in the 500 Hz range.
SP Band Ctrl3	-15–+15 [dB]	Sets the gain (amount of boost/cut) in the 1000 Hz range.
SP Band Ctrl4	-15–+15 [dB]	Sets the gain (amount of boost/cut) in the 2000 Hz range.
SP Band Ctrl5	-15–+15 [dB]	Sets the gain (amount of boost/cut) in the 4000 Hz range.
SP Band Ctrl6	-15–+15 [dB]	Sets the gain (amount of boost/cut) in the 8000 Hz range.
SP Width	1–5	Sets the bandwidth for changing the levels, common to all bands.
EH Switch	OFF, ON	Turns the enhancer on/off.
EH Sens	0–100	Sets how easily the enhancer effect is applied.
EH Mix	0–100	Sets the ratio at which the harmonics generated by the enhancer are mixed with the original sound.
Pan	L64–63R	Changes the pan.
Level	0–127	Sets the output volume.

Chorus parameters

Chorus common parameters

Parameter	Value	Explanation
Type	OFF A (SIMPLE) B (COMBI) C (JX)	Selects the chorus type.
Mode	Select the mode. The selectable values depend on the type. I, II, III, I+II, I+III, II+III, I+II+III, JX I, JX II	A (SIMPLE): I, II, III B (COMBI): I+II, I+III, II+III, I+II+III (the state where multiple buttons are pressed at the same time). C (JX): JX I, JX II
Noise Level	0–127	Adjusts the volume of noise generated by chorus.
Dry Level	0–127	Sets the output level of the original sound.
Wet Level	0–127	Specifies the output level of the sound with chorus applied.
Chorus Send	0–127	Adjusts the level of original sound sent to the chorus.
Chorus Level	0–127	Adjusts the overall output volume.

Reverb/Delay parameters assignment list

Type	REV/DELAY CTRL1		REV/DELAY CTRL2		REV/DELAY LEVEL		REV/DELAY LEVEL + [SHIFT]	
	Parameter	LFO Asgn	Parameter	LFO Asgn	Parameter *4	LFO Asgn	Parameter *4	LFO Asgn
Shimmer Reverb	Time	—	Pitch1, 2 Feedback *1	✓	Wet Level	✓	Send Amount	✓ *5
Modulation Reverb	Time	✓	Modulation Depth	✓	Effect Level	✓	Send Amount	✓ *5
INTEGRA-7 Reverb	Time	✓	LF Damp, HF Damp *2	✓	Wet Level	✓	Send Amount	✓ *5
SRV-2000 Reverb	Time	—	HF Damp		Wet Level	✓	Send Amount	✓ *5
Delay	Delay Time	—	Feedback	✓	Wet Level	✓	Send Amount	✓ *5
2Tap PanDly	Delay Time *3	✓	Feedback	✓	Wet Level	✓	Send Amount	✓ *5
Tape Echo	Repeat Rate	✓	Intensity	✓	Echo Level	✓	Send Amount	✓ *5

*1 Both Pitch 1 and 2 Feedback change at the same time.

*2 When you turn the [CTRL 2] knob clockwise, the LF Damp value increases and the HF Damp value decreases.

*3 When Rate Sync Switch is ON, the Rate changes depending on the note you play. LFO assign is disabled.
When Rate Sync Switch is OFF, the Rate changes in Hz or in msec.

*4 SOUND/CTRL/REV/DLY knob: The parameter assignment is reversed when this is set to REVERSE.

*5 SOUND/CTRL/REV/DLY knob: The LFO assignment is enabled when this is set to REVERSE.

Reverb/Delay common parameters

Parameter	Value	Explanation
Switch	OFF, ON	Switches reverb/delay on/off.
Type	00–07	Selects the types of reverb/delay.
Send Amount	0–127	Adjusts the level of original sound sent to the reverb.
Level	0–127	Adjusts the overall output volume.

00 Thru

01 Shimmer Reverb

A reverb that includes two pitch-shifted sounds and the original audio input. This is a reverb with a brilliant-sounding high end.

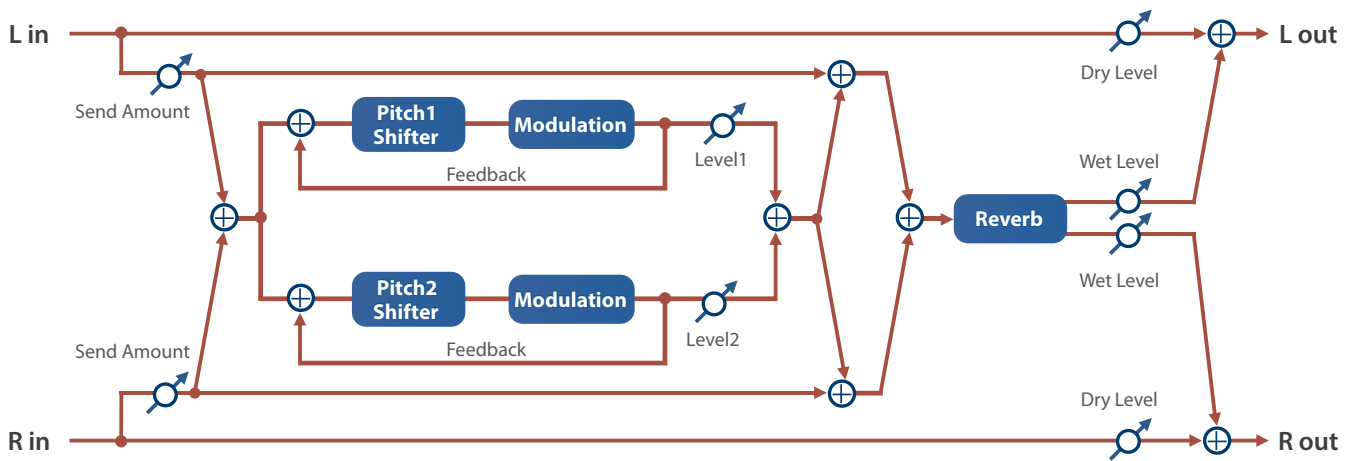

Parameter	Value	Explanation
Low Damp	-50–+50	Adjusts the amount by which to attenuate the low-frequency portion of the reverb.
High Damp	-50–+50	Adjusts the amount by which to attenuate the high-frequency portion of the reverb.
Time	0.1–10.0 [sec]	Adjusts the decay length of the reverb sound.
Density	1–10	Adjusts the density of the reverb sound.
Pre Delay	0–200 [msec]	Adjusts how long it takes until the reverb sound is heard, after the direct sound plays.
Modulation Rate	0–100	Adjusts the speed at which the reverb sound is modulated.
Modulation Depth	0–100	Adjusts the depth to which the reverb sound is modulated.
Pitch1 Coarse	-24–+24 [semi]	Adjusts the amount of pitch shift applied for pitch shift 1. (in semitones)
Pitch2 Coarse	-24–+24 [semi]	Adjusts the amount of pitch shift applied for pitch shift 2. (in semitones)
Pitch1 Feedback	-98–+98 [%]	Adjusts the proportion of the delay sound that is fed back into pitch shift 1 (Negative values invert the phase).
Pitch2 Feedback	-98–+98 [%]	Adjusts the proportion of the delay sound that is fed back into pitch shift 2 (Negative values invert the phase).
Level 1	0–100	Adjusts the volume of pitch shift 1.
Level 2	0–100	Adjusts the volume of pitch shift 2.
Dry Level	0–127	Adjusts the volume of the original sound.
Wet Level	0–127	Adjusts the volume of the reverb sound.

02 Modulation Reverb

A reverb that inputs the modulated original sound.

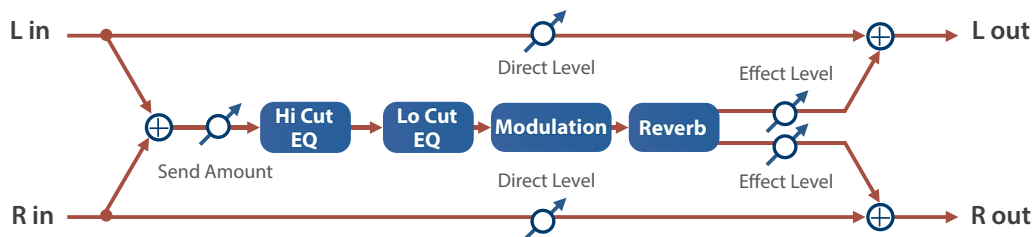

Parameter	Value	Explanation
Modulation Depth	0–127	Adjusts the depth of modulation.
Rate	0.05–5.00 [Hz]	Adjusts the frequency of modulation.
Time	0–100	Adjusts the decay length of the reverb sound.
Low Cut	Sets the base frequency for cutting the low-frequency portion of the inputted modulated sound. FLAT, 20, 25, 31, 40, 50, 63, 80, 100, 125, 160, 200, 250, 315, 400, 500, 630, 800 [Hz]	
High Cut	Sets the base frequency for cutting the high-frequency portion of the inputted modulated sound. 630, 800, 1000, 1250, 1600, 2000, 2500, 3150, 4000, 5000, 6300, 8000, 10000, 12500, FLAT (Hz)	
Pre Delay	0–100	Adjusts how long it takes until the reverb sound is heard, after the direct sound plays.
Density	0–100	Adjusts the density of the reverb sound.
Direct Level	0–127	Adjusts the volume of the original sound.
Effect Level	0–127	Adjusts the volume of the reverb sound.

03 INTEGRA-7 Reverb

A reverb built into the Roland INTEGRA-7 sound module.

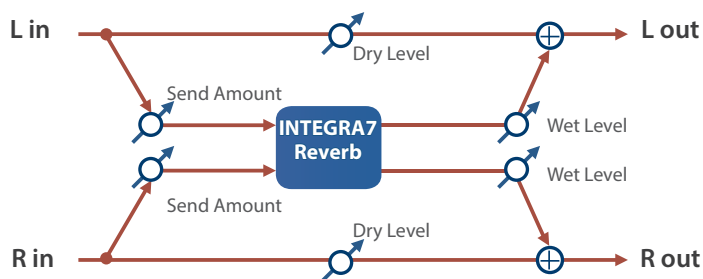

Parameter	Value	Explanation
Char	ROOM1, ROOM2, HALL1, HALL2, PLATE	Selects the type of reverb.
PreDelay	0–100	Adjusts the delay time from when the direct sound plays until the reverb sound is heard.
Time	0.1–10.0 [sec]	Adjusts the decay length of the reverb sound.
Density	0–127	Adjusts the density of the reverb sound.

Parameter	Value	Explanation
Diffusion	0–127	Adjusts how reverb density increases over time (This effect is especially noticeable with long reverb times).
LF Damp	0–100	Adjusts the low-frequency portion of the reverb.
HF Damp	0–100	Adjusts the high-frequency portion of the reverb.
Spread	0–127	Adjusts the reverb spread.
Tone	0–127	Adjust the tonal character of the reverb.
Dry Level	0–127	Adjusts the volume of the original sound.
Wet Level	0–127	Adjusts the volume of the reverb sound.

04 SRV-2000 Reverb

A reverb that emulates the Roland SRV-2000 digital reverb.

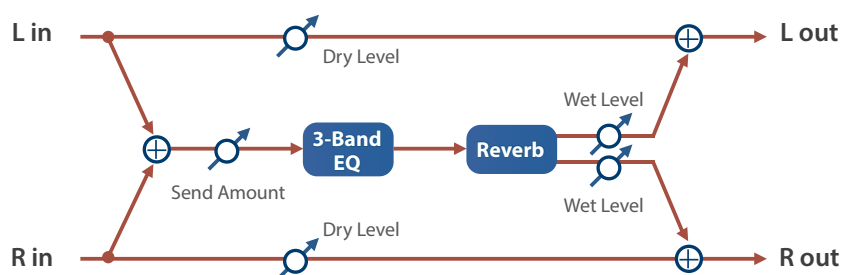

Parameter	Value	Explanation
Selection	Selects the type of reverb offered by the Roland SRV-2000 digital reverb. R0.3, R1.0, R7.0, R15, R22, R26, R32, R37, H15, H22, H26, H32, H37, P-B, P-A	
PreDelay	0–160	Adjusts the delay time from when the direct sound plays until the reverb sound is heard.
Time	0.1–99.0 [sec]	Adjusts the decay length of the reverb sound.
HF Damp	0.05–1.00	Adjusts the high-frequency portion of the reverb.
Density	0–9	Adjusts the density of the late reverberation.
Attack Gain	0–9	Adjusts the gain of the early reflections.
Attack Time	0–9	Adjusts the time of the early reflections.
ER Density	0–9	Adjusts the density of the early reflections.
ER Level	0–99	Adjusts the volume of the early reflections.
Low Freq	0.04–1.00 [kHz]	Frequency of the low range.
Low Gain	-24–+12 [dB]	Gain of the low range.
Mid Freq	0.25–9.99 [kHz]	Frequency of the middle range.
Mid Gain	-24–+12 [dB]	Gain of the middle range.
Mid Q	0.2–9.0	Width of the middle range. Set a higher value for Q to narrow the range to be affected.
HighFreq	0.80–9.99 [kHz]	Frequency of the high range.
HighGain	-24–+12 [dB]	Gain of the high range
High Q	0.2–9.0	Specifies the width of the high-frequency range. Set a higher value for Q to narrow the range to be affected.
Dry Level	0–127	Adjusts the volume of the original sound.
Wet Level	0–127	Adjusts the volume of the reverb sound.

05 Delay

This is a stereo delay.

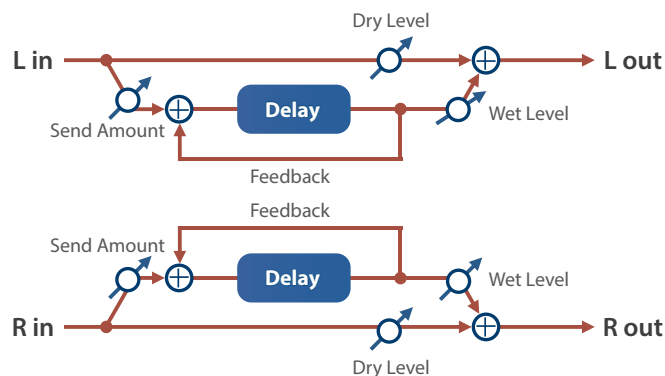

Parameter	Value	Explanation
Dly Sync	OFF, ON	If this is ON, the delay synchronizes with the tempo.
Dly Msec	1–1300	Adjusts the delay time from the direct sound until the delay sound is heard.
Dly Note	Note	1/64T, 1/64, 1/32T, 1/32, 1/16T, 1/32., 1/16, 1/8T, 1/16., 1/8, 1/4T, 1/8., 1/4, 1/2T, 1/4., 1/2, 1T, 1/2., 1, 2T, 1., 2
Feedback	-98–+98 [%]	Adjusts the proportion of the delay sound that is fed back into the effect (Negative values invert the phase).
HF Damp	Adjusts the frequency above which the delay sound fed back to the effect is filtered out (BYPASS : no cut). 200, 250, 315, 400, 500, 630, 800, 1000, 1250, 1600, 2000, 2500, 3150, 4000, 5000, 6300, 8000 [Hz], BYPASS	
Dry Level	0–127	Adjusts the volume of the original sound.
Wet Level	0–127	Adjusts the volume of the reverb sound.

06 2Tap PanDly (2 Tap Pan Delay)

The delay sound is heard both at the left and at the right.

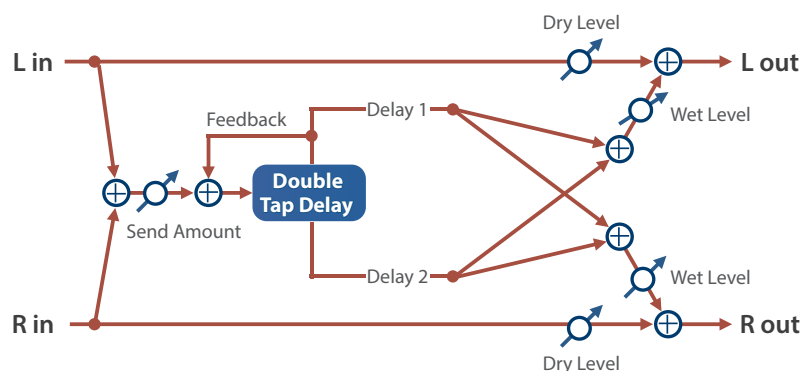

Parameter	Value	Explanation
Dly Sync	OFF, ON	If this is ON, the delay synchronizes with the tempo.
Dly Msec	1–1300	Adjusts the delay time from the direct sound until the second delay sound is heard.
Dly Note	Note	
Feedback	-98–+98 [%]	Adjusts the proportion of the delay sound that is fed back into the effect.
HF Damp	Adjusts the frequency above which the delay sound fed back to the effect is filtered out (BYPASS : no cut). 200, 250, 315, 400, 500, 630, 800, 1000, 1250, 1600, 2000, 2500, 3150, 4000, 5000, 6300, 8000 [Hz], BYPASS	
Dly1 Pan	L64–63R	Adjusts the stereo location of delay 1.
Dly2 Pan	L64–63R	Adjusts the stereo location of delay 2.
Dly1 Level	0–127	Adjusts the volume of delay 1.

Parameter	Value	Explanation
Dly2 Level	0–127	Adjusts the volume of delay 2.
Dry Level	0–127	Adjusts the volume of the original sound.
Wet Level	0–127	Adjusts the volume of the reverb sound.

07 Tape Echo

A virtual tape echo that produces a realistic tape delay sound. This simulates the tape echo section of a Roland RE-201 Space Echo.

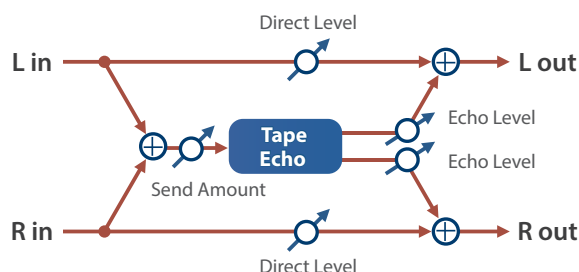

Parameter	Value	Explanation
Mode	S, M, L, S+M, S+L, M+L, S+M+L	Combination of playback heads to use. Select from three different heads with different delay times. S: short, M: middle, L: long
Repeat Rate	0–127	Tape speed. Increasing this value will shorten the spacing of the delayed sounds.
Intensity	0–127	Amount of delay repeats
Bass	-15–+15 [dB]	Boost/cut for the lower range of the echo sound
Treble	-15–+15 [dB]	Boost/cut for the upper range of the echo sound
Head S Pan	L64–63R	Independent panning for the short, middle, and long playback heads
Head M Pan	L64–63R	
Head L Pan	L64–63R	
Distortion	0–5	Amount of tape-dependent distortion to be added. This simulates the slight tonal changes that can be detected by signal-analysis equipment. Increasing this value will increase the distortion.
Wf Rate	0–127	Speed of wow/flutter (complex variation in pitch caused by tape wear and rotational irregularity)
Wf Depth	0–127	Depth of wow/flutter
Echo Level	0–127	Volume of the echo sound
Direct Lv	0–127	Volume of the original sound
Level	0–127	Output Level

Note parameters

1/64T	Sixty-fourth-note triplet	1/64	Sixty-fourth note	1/32T	Thirty-second-note triplet		
1/32	Thirty-second note	1/16T	Sixteenth-note triplet	1/32.	Dotted thirty-second note		
1/16	Sixteenth note	1/8T	Eighth-note triplet	1/16.	Dotted sixteenth note		
1/8	Eighth note	1/4T	Quarter-note triplet	1/8.	Dotted eighth note		
1/4	Quarter note	1/2T	Half-note triplet	1/4.	Dotted quarter note		
1/2	Half note	1T	Whole-note triplet	1/2.	Dotted half note		
1	Whole note	2T	Double-note triplet	1.	Dotted whole note	2	Double note

SYSTEM parameters

Parameter	Value	Explanation
SYSTEM GENERAL		
MasterTune	415.3–466.2 [Hz]	Adjusts the overall tuning. The displayed value is the frequency of the A4 key (middle A).
MasKeyShift	-24–+24	Shifts the overall pitch range in semitone steps.
Tempo	20.00–300.00	Specifies the system tempo.
Tempo Src	TONE, SYS	Sets how the tempo changes when switching between tones. TONE: Follows the tempo stored in the tone. SYS: Follows the system tempo.
Metronome	OFF, ON	Turn this off if you don't want the metronome to play during recording.
Metro Type	TYPE1, TYPE2	Selects the metronome's sound.
Metro Count-In	OFF, 1–16	Sets the number of beats used for the metronome count-in when real-time recording begins.
Metro Lev	1–127	Adjusts the metronome's volume.
LineOut Gain	-12–+12 [dB]	Adjusts the output gain of OUTPUT/PHONES.
LED Bright	1–10	Adjusts the brightness of the LEDs.
Auto Off	OFF, 30, 240	Specifies whether the unit will turn off automatically after a certain time has elapsed. If you don't want the unit to turn off automatically, choose OFF setting.
Startup Mode	TONE, LAST	Sets the startup tone. TONE: The instrument starts up with the tone specified in Startup Tone. LAST: The instrument starts up with the tone last selected before you turned off the power.
Startup Tone	USER A1-1–H8-8, PRESET A1-1–D8-8	The instrument starts up with the tone you specify here when Startup Mode is set to "TONE".
Display Style	Normal, Simple	Set this to "Simple" when you only want to show the tone number and tone name on the top screen.
Screen Saver Type	1–10	Selects the type of screen saver.
Screen Saver Time	1, 5, 10 [min]	Sets the time before the screen saver starts (in minutes).
Param Pop-Up Time	OFF, 0.1–2.0 [sec]	Sets how long the parameter popup appears, which is shown when you operate the panel.
View Pop-Up Time	OFF, 0.1–2.0 [sec]	Sets how long the graphical popup appears, which is shown when you operate the panel.
SYSTEM CONTROL		
Velocity	REAL, 1–127	Specifies the velocity value that is transmitted when you play the keyboard.
Velo Crv	LIGHT, MEDIUM, HEAVY	Specifies "Strength" for keyboard touch.
Velo Offset	-10–+9	Adjusts the keyboard velocity curve.
Knob Mode	DIRECT, CATCH	Specifies whether the parameter value corresponding to a controller is immediately updated when you operate that controller (DIRECT) or only after the controller reaches the same position as the parameter's current value (CATCH).

Parameter	Value	Explanation
PedalSource	TONE, SYS	Sets how the function assigned to the pedal that's connected to the PEDAL jack works. TONE: The currently selected tone's settings are used. SYS: The system's settings are used.
Pedal Function	Specifies the function assigned to the pedal connected to the PEDAL jack. OFF, MODULATION, HOLD1, EXPRESSION, VOLUME, PAN, BEND DOWN, BEND UP, HOLD SW, MONO SW, MFX SW, CHO LEVEL, REV LEVEL, REV SEND, BEND MODE, ARP SW, ARP SHUFFLE, ARP DURATION, START/STOP, TAP TEMPO, TONE DOWN, TONE UP	
Pedal Pole	STANDARD, REVERSE	Specifies the polarity of the pedal connected to the PEDAL jack.
Motional Pad UI Sw	OFF, ON	Set this to "OFF" if you don't want to use the motional pad to operate the screen.
Motional Pad Sens	OFF, LOW, MID, HIGH	Selects the motional pad sensitivity.
SYSTEM MIDI		
MIDI Ch	1–16	Sets which MIDI channel is used for transmitting/receiving performance data for the GAIA-2.
Omni Mode	OFF, ON	When this is ON, messages from all MIDI channels are received.
Soft Thru	OFF, ON	If this is ON, MIDI messages that are input from the MIDI IN connector are re-transmitted without change from the MIDI OUT connector.
Remote Kbd	OFF, MIDI IN, USB COM, USB MEM	Sets which connector is used for input when you use an external MIDI keyboard instead of the keyboard of the GAIA-2. In this case, the MIDI transmit channel of the external MIDI keyboard does not matter. Normally you will leave this OFF.
Local Sw	OFF, ON	Enables/disable the connection between the controller section (keyboard, pitch wheel, MOD wheel, etc.) and the internal sound engine.
Device ID	17–32	When transmitting and receiving system exclusive messages, the device ID numbers of both devices must match.
Sync Mode	AUTO, INT, MIDI, USB COM, USB MEM	Sets the port or connector used to receive the synchronization signal.
Sync Out	OFF, MIDI, USB COM, MIDI/USBCM, USB MEM, ALL	Sets the port or connector used to output the clock, start and stop MIDI messages.
Arp Sync	OFF, BEAT, MEASURE	Specifies how the arpeggio is synchronized when this unit is connected to an external device and is playing in synchronization. OFF: The arpeggio does not synchronize to the measure or beat. The arpeggio starts the moment that MIDI messages are received. BEAT: The arpeggio synchronizes to the beat. The arpeggio starts at the next beat after MIDI is received. MEASURE: The arpeggio synchronizes to the measure. The arpeggio starts at the first beat of the next measure after MIDI is received.
CC Map	OFF, TONE CC, PANEL CC	OFF: CC (control change messages) not assigned to the panel operations or parameter changes are not transmitted/received. TONE CC: CC that are assigned to parameters are transmitted/received. PANEL CC: CC that are assigned to the panel controls are transmitted/received. You can use MIDI to perform operations that are similar to what you can do with sequencer motions.

Parameter	Value	Explanation
Tx PC	OFF, ON	Specifies whether program change messages will be transmitted (ON) or not be transmitted (OFF).
Tx Bank	OFF, ON	Specifies whether bank select messages will be transmitted (ON) or not be transmitted (OFF).
Tx Edit	OFF, ON	Specifies whether changes you make to a parameter are transmitted as system exclusive messages (ON) or not (OFF).
Rx PC	OFF, ON	Specifies whether program change messages will be received (ON) or not be received (OFF).
Rx Bank	OFF, ON	Specifies whether bank select messages will be received (ON) or not be received (OFF).
Rx Exclusive	OFF, ON	Specifies whether system exclusive messages will be received (ON) or not be received (OFF).
Rx Bend	OFF, ON	Specifies whether pitch bend is received (ON) or not received (OFF).
Rx Poly Pres	OFF, ON	Specifies whether polyphonic aftertouch is received (ON) or not received (OFF).
Rx Ch Pres	OFF, ON	Specifies whether channel aftertouch is received (ON) or not received (OFF).
Rx Mod	OFF, ON	Specifies whether modulation is received (ON) or not received (OFF).
Rx Volume	OFF, ON	Specifies whether volume is received (ON) or not received (OFF).
Rx Pan	OFF, ON	Specifies whether pan is received (ON) or not received (OFF).
Rx Exp	OFF, ON	Specifies whether expression is received (ON) or not received (OFF).
Rx Hold-1	OFF, ON	Specifies whether hold 1 is received (ON) or not received (OFF).
Rx StartStop	OFF, ON	Specifies whether start/stop is received (ON) or not received (OFF).
SYSTEM USB		
USB In Lev	0–127	Adjusts the audio input level of the USB COMPUTER port.
USB Out Lev	0–127	Adjusts the audio output level to the USB COMPUTER port.
USB Audio Thru	OFF, ON	Specifies whether the audio input of the USB COMPUTER port is mixed into the audio output of the USB COMPUTER port. If you don't want it to be output as audio, turn this OFF.
USB-MIDI Thru	OFF, ON	Specifies whether MIDI messages received at the USB COMPUTER port/MIDI IN connector are retransmitted without change from the MIDI OUT connector/USB COMPUTER port (ON) or are not retransmitted (OFF).
USB Driver	GENERIC, VENDOR	Selects the USB driver.

MASTER EFFECTS

Parameter	Value	Explanation
MASTER EQ		
Switch	OFF, ON	Specifies whether the mastering EQ (an equalizer applied to the entire sound generator of the GAIA-2) is used (ON) or not used (OFF).
In Gain	-24+24 [dB]	Adjusts the amount of boost/cut for the input to the EQ.
Low Freq	20-16000 [Hz]	Frequency of the low range.
Low Gain	-24+24 [dB]	Gain of the low range.
Mid1 Freq	20-16000 [Hz]	Frequency of the middle range 1.
Mid1 Q	0.5, 1.0, 2.0, 4.0, 8.0, 16.0	Width of the middle frequency range 1. Set a higher value for Q to narrow the range to be affected.
Mid1 Gain	-24+24 [dB]	Gain of the middle frequency range 1.
Mid2 Freq	20-16000 [Hz]	Frequency of the middle range 2.
Mid2 Q	0.5, 1.0, 2.0, 4.0, 8.0, 16.0	Width of the middle frequency range 2. Set a higher value for Q to narrow the range to be affected.
Mid2 Gain	-24+24 [dB]	Gain of the middle frequency range 2.
Mid3 Freq	20-16000 [Hz]	Frequency of the middle range 3.
Mid3 Q	0.5, 1.0, 2.0, 4.0, 8.0, 16.0	Width of the middle frequency range 3. Set a higher value for Q to narrow the range to be affected.
Mid3 Gain	-24+24 [dB]	Gain of the middle frequency range 3.
High Freq	20-16000 [Hz]	Frequency of the high range.
High Gain	-24+24 [dB]	Gain of the high range
MASTER COMP		
Switch	OFF, ON	Specifies whether the mastering COMP (a compressor applied to the entire sound generator of the GAIA-2) is used (ON) or not used (OFF).
Low Attack	0.1-100 [ms]	Specifies the time from when the input exceeds Low Thres until compression is applied to the volume of the low-frequency band.
Low Rels	10-1000 [ms]	In a state when compression is already being applied, this specifies the time from when the input decreases below Low Thres until the low-frequency band stops being compressed.
Low Thres	-60-0 [dB]	Specifies the volume level at which compression starts for the low-frequency band.
Low Ratio	1:1, 2:1, 3:1, 4:1, 8:1, 16:1, 32:1, INF:1	Specifies the compression ratio for the low-frequency band.
Low Knee	0-30 [dB]	This function smooths out the sonic transition, from when the compression is not engaged until when the compression begins. This gradually applies compression from just before the Low Thres point. Higher values produce a smoother transition.
Low Gain	-24+24 [dB]	Specifies the output volume of the low-frequency band.
Mid Attack	0.1-100 [ms]	Specifies the time from when the input exceeds Mid Thres until compression is applied to the volume of the mid-frequency band.
Mid Rels	10-1000 [ms]	In a state when compression is already being applied, this specifies the time from when the input decreases below Mid Thres until the mid-frequency band stops being compressed.
Mid Thres	-60-0 [dB]	Specifies the volume level at which compression starts for the mid-frequency band.

Parameter	Value	Explanation
Mid Ratio	1:1, 2:1, 3:1, 4:1, 8:1, 16:1, 32:1, INF:1	Specifies the compression ratio for the mid-frequency band.
Mid Knee	0–30 [dB]	This function smooths out the sonic transition, from when the compression is not engaged until when the compression begins. This gradually applies compression from just before the Mid Thres point. Higher values produce a smoother transition.
Mid Gain	-24–+24 [dB]	Specifies the output volume of the mid-frequency band.
High Attack	0.1–100 [ms]	Specifies the time from when the input exceeds High Thres until compression is applied to the volume of the high-frequency band.
High Rels	10–1000 [ms]	In a state when compression is already being applied, this specifies the time from when the input decreases below High Thres until the high-frequency band stops being compressed.
High Thres	-60–0 [dB]	Specifies the volume level at which compression starts for the high-frequency band.
High Ratio	1:1, 2:1, 3:1, 4:1, 8:1, 16:1, 32:1, INF:1	Specifies the compression ratio for the high-frequency band.
High Knee	0–30 [dB]	This function smooths out the sonic transition, from when the compression is not engaged until when the compression begins. This gradually applies compression from just before the High Thres point. Higher values produce a smoother transition.
High Gain	-24–+24 [dB]	Specifies the output volume of the high-frequency band.
Splt Low	16–16000 [Hz]	Specifies the frequency at which the low-frequency band (Low) and mid-frequency band (Mid) are divided.
Splt High	16–16000 [Hz]	Specifies the frequency at which the high-frequency band (High) and mid-frequency band (Mid) are divided.

Wavetable list

No.	Name
01	SyncShift WT
02	4waves morph
03	Sine Garden
04	Sine To Dist
05	Sine Blend
06	Shiner
07	Circuit
08	EffEmm One
09	Growl FM
10	Scratch Mod
11	Syn Guitar
12	Inharmonic
13	Hubble
14	Vowel Sweep
15	Phase Ride
16	Future Acid
17	Glass Cas
18	Skirt Steak
19	Bend Wave
20	Digi Bark
21	Ripple
22	Saw Spectral
23	Syn Sweep
24	AEIOU Warp
25	Rhythm Warp1
26	Rhythm Warp2
27	Wavefold
28	FM Oct Mod
29	Can Tank
30	Morph Mode
31	Seared
32	Bell Mod
33	Bell
34	FM Bells
35	Vector
36	EffEmm Two
37	FM Parade

No.	Name
38	Erm Wah
39	Spect2
40	OnceWasNoise
41	Modulant
42	Shape Mod
43	Dist Saw Mod
44	Edge Morph
45	Metal Mod
46	Sparseness
47	UniSqr Spctl
48	Can Crash
49	A E I O U
50	Voxylor
51	Mosquito
52	Robovoxxy
53	Why Bass
54	Yoo
55	Say What
56	GAIA
57	We Design
58	Ac Gtr Slide
59	JP-8K FbkOSC
60	IntrmissivWT
61	Saw Stortion
62	Chord Wave
63	Rhythm Loop

Panel parameters assignment list (GAIA-2)

Panel Device		Parameter Assign [SHIFT] +	Motion Assign X/Y	LFO1 Asgn	LFO2 Asgn	CC Assign	Step Seq Smooth
LFO1	RATE	LFO1 Rate / LFO1 Rate Note (selected by LFO1 SYNC)	✓	-	✓	29, 21	
	SYNC	LFO1 Sync Switch	-	-	-	20	OFF
	WAVE	LFO1 Waveform	-	-	-	35	OFF
	DEPTH1	LFO1 Assign1 Depth	✓	-	-	26	
	ASSIGN1	LFO1 Assign1 Destination	-	-	-	-	-
	DEPTH2	LFO1 Assign2 Depth	✓	-	-	28	
	ASSIGN2	LFO1 Assign2 Destination	-	-	-	-	-
	DEPTH3	LFO1 Assign3 Depth	✓	-	-	30	
	ASSIGN3	LFO1 Assign2 Destination	-	-	-	-	-
	DEPTH4	LFO1 Assign4 Depth	✓	-	-	31	
ASSIGN4	LFO1 Assign2 Destination	-	-	-	-	-	
LFO2	RATE	LFO2 Rate / LFO2 Rate Note (selected by LFO2 SYNC)	✓	✓	-	56, 47	
	SYNC	LFO2 Sync Switch	-	-	-	46	OFF
	WAVE	LFO2 Waveform	-	-	-	59	OFF
	DEPTH1	LFO2 Assign1 Depth	✓	-	-	53	
	ASSIGN1	LFO2 Assign1 Destination	-	-	-	-	-
	DEPTH2	LFO2 Assign2 Depth	✓	-	-	55	
	ASSIGN2	LFO2 Assign2 Destination	-	-	-	-	-
	DEPTH3	LFO2 Assign3 Depth	✓	-	-	57	
	ASSIGN3	LFO2 Assign2 Destination	-	-	-	-	-
	DEPTH4	LFO2 Assign4 Depth	✓	-	-	58	
ASSIGN4	LFO2 Assign2 Destination	-	-	-	-	-	
OSC1	RANGE	OSC1 Range	-	-	-	60	OFF
	Pitch	OSC1 Pitch	OSC1 Pitch (pitch changes in semitones)	✓	✓	✓	61
	TABLE	OSC1 Wavetable No.	-	-	-	-	-
	POSITION	OSC1 Position	✓	✓	✓	63	
OSC2	RANGE	OSC2 Range	-	-	-	102	OFF
	Pitch	OSC2 Pitch	OSC2 Pitch (pitch changes in semitones)	✓	✓	✓	103
	WAVE	OSC2 Waveform	-	-	-	104	OFF
	SHAPE	OSC2 Shape	✓	✓	✓	105	
OSC3	RANGE	OSC3 Range	-	-	-	111	OFF
	Pitch	OSC3 Pitch	OSC3 Pitch (pitch changes in semitones)	✓	✓	✓	112
	WAVE	OSC3 Waveform	-	-	-	113	OFF
	SHAPE	OSC3 Shape	✓	✓	✓	114	
MIXER	OSC1	OSC1 LEVEL	✓	✓	✓	16	
	OSC2	OSC2 LEVEL	✓	✓	✓	17	
	OSC3	OSC3 LEVEL	✓	✓	✓	18	
	XMOD	CrossMod Depth/CrossMod2 Depth (selected by XMOD TYPE)	✓	✓	✓	52	
	ENV DEPTH	Pitch Env Depth	✓	✓	✓	22	
	A	Pitch Env Attack Time	✓	✓	✓	23	
	D	Pitch Env Decay Time	✓	✓	✓	24	
	SYNC/RING	Ring Sync Switch	-	-	-	25	OFF

Panel Device		Parameter Assign [SHIFT] +	Motion Assign X/Y	LFO1 Asgn	LFO2 Asgn	CC Assign	Step Seq Smooth	
FILTER	KEY FOLLOW	Filter Cutoff Keyfollow	-	-	-	82		
	ENV DEPTH	Filter Env Depth	✓	✓	✓	81		
	A	Filter Env Attack Time	✓	✓	✓	83		
	D	Filter Env Decay Time	✓	✓	✓	84		
	S	Filter Env Sustain Level	-	-	-	85		
	R	Filter Env Release Time	✓	✓	✓	86		
	DRIVE	Filter Drive	Drive Makup Sens	✓	✓	✓	87, 115	
	CUTOFF	Filter Cutoff		✓	✓	✓	3	
	RESONANCE	Filter Resonance		✓	✓	✓	9	
	TYPE	Filter Type		-	-	-	108	OFF
SLOPE	Filter Slope		-	-	-	109	OFF	
AMP	LEVEL	Amp Level	✓	✓	✓	110		
	TONE	TONE	✓	-	-	69		
	A	Amp Env Attack Time	✓	✓	✓	89		
	D	Amp Env Decay Time	✓	✓	✓	90		
	S	Amp Env Sustain Level	-	-	-	96		
R	Amp Env Release Time	✓	✓	✓	97			
MFX	ON/OFF		-	-	-	79	OFF	
	TYPE		-	-	-	-		
	CTRL1		✓	✓	✓	12		
	CTRL2		✓	✓	✓	13		
CHORUS	CTRL3		✓	✓	✓	14		
	TYPE		-	-	-			
REVERB/ DELAY	TYPE	Switch	-	-	-	(95)		
	CTRL1		✓	✓	✓	44		
	CTRL2		✓	✓	✓	45		
	LEVEL *1		✓	✓	✓	94		
	SEND *1		✓	-	-	91		
VOICE	MONO	Mono/Poly Switch	Legato Switch	-	-	-	119, 118	OFF
	PORTAMENTO	Portamento Time	UNISON Detune, Spread	-	-	-	5, 92	
OTHER	VELOCITY			-	-	-		
	CHORD			-	-	-		
	HOLD			-	-	-		
	OCTAVE			-	-	-		
	TRANSPOSE			-	-	-		
	VOLUME			-	-	-		
	TEMPO			-	-	-		
	Pitch			-	-	-		
	MOD			-	-	-	1	
MOTIONAL PAD	P-MOD X		✓	-	-	48		
	P-MOD Y		✓	-	-	49		
	S-MOD DPT		✓	-	-	50		
	S-MOD DRV		✓	-	-	51		
	X-ASSIGN			-	-	-	(106)	
	Y-ASSIGN			-	-	-	(107)	
ARPEGGIO	ON	ARP SW		-	-	-	15	OFF
	MODE	MODE	OCT RANGE	-	-	-	70, 117	OFF
	SCALE	SCALE	DURATION	-	-	-	80, 116	OFF

*1: When you set the CONTROL parameter "REV/DLY Knob MODE" to "SEND", the [LEVEL/SEND] knob operations are swapped.

The basic operating method (editing, menus) for the SH-101 Model Expansion is the same as for the GAIA-2 original sound module.

- You can use the sequencer, arpeggio, chord memory and motional pad in the same way as with the GAIA-2 original sound module.
- You can't use the P-Mod/S-Mod, parameter assignment to the LFOs or the step LFO functionality.

Attribute (M: MODEL)
Group (A-H)
Bank number (1-8)
Tone number (1-8)
Model name (SH-101)

1 VALUE Select a tone (A1-1-H8-8)
SHIFT + ENTER Reloads the tone

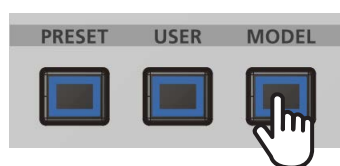

- 1** MODEL Selects a model tone
- 2** SHIFT+ 1-8 Selects the group (A-H)
- 3** 1-8 Selects the bank number (1-8)
- 4** 9-16 Selects the tone number (1-8)

Switching between models

Aside from the SH-101 model expansion that's pre-installed at the factory, you can install and use other model expansions such as JUPITER-8 and JUNO-106 from Roland Cloud (paid contents).

1 Return to TOP screen

2 Long-press MODEL Jump to SELECT MODEL screen SHIFT+ MODEL

3 VALUE Selects the model

* If a model expansion has not been additionally installed, only "SH-101" is shown.

4 ENTER Switch

When editing a model tone, you can check the controller assignment information on the PANEL VIEW screen as you edit.

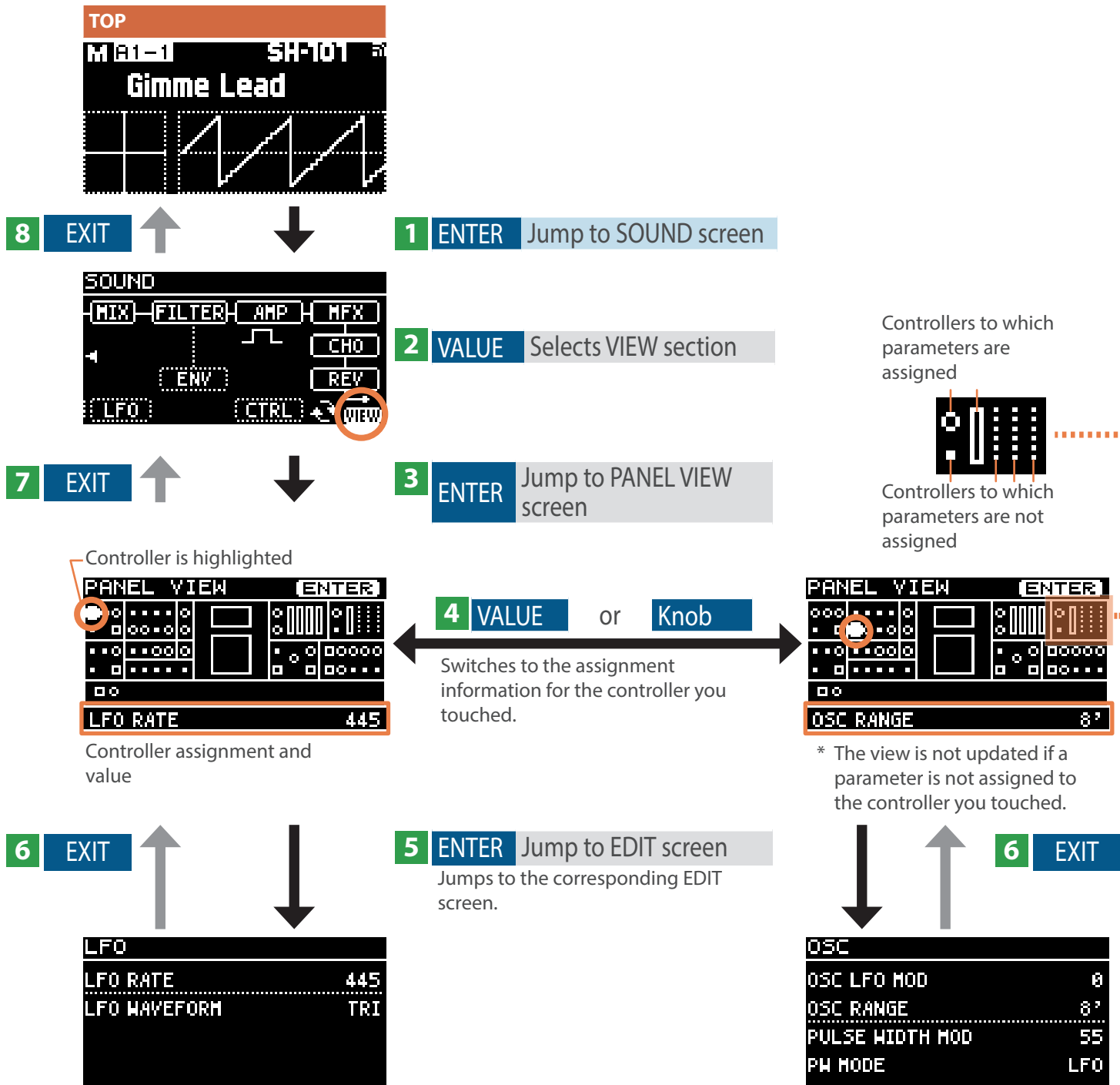

Panel parameters assignment list (SH-101)

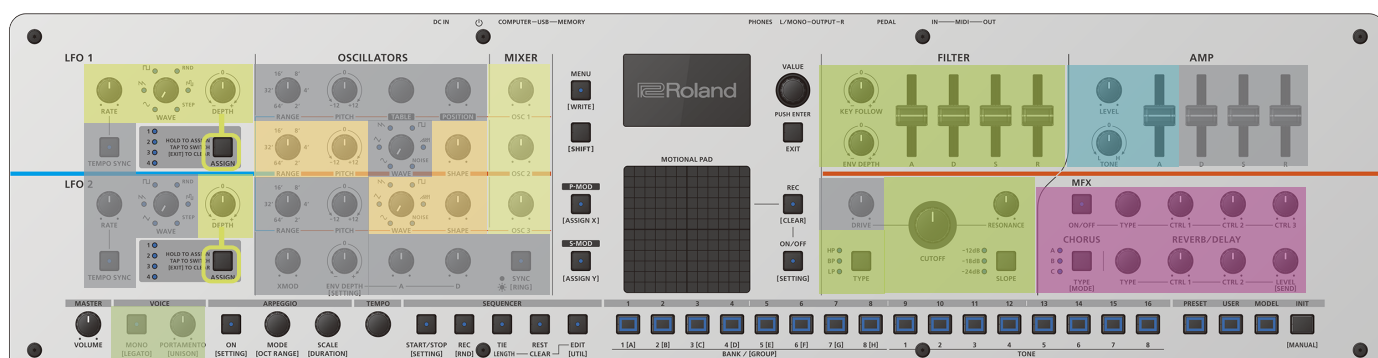

Panel Device	Parameter Assign	[SHIFT] +	Motion Assign X/Y	CC Assign
LFO1	RATE	LFO RATE	✓	29
	WAVE	LFO WAVEFORM	-	35
	DEPTH1	OSC LFO MOD *1	✓	26
	DEPTH2	FILTER MOD *1	✓	28
LFO2	DEPTH1	MODULATION LFO *2	✓	53
	DEPTH2	BEND PITCH *2	✓	55
	DEPTH3	BEND FILTER *2	✓	57
	DEPTH4	PORTA CRV *2	✓	58
OSC1				
OSC2	RANGE	OSC RANGE	-	102
	PITCH	PW MODE	-	103
	SHAPE	PULSE WIDTH MOD	✓	105
OSC3	WAVE	SUB OSC	-	113
	SHAPE	NOISE LEVEL	✓	114
MIXER	OSC1	SUB OSC LEVEL	✓	16
	OSC2	PW LEVEL	✓	17
	OSC3	SAW LEVEL	✓	18
FILTER	KEY FOLLOW	FLT KEY FOLLOW	-	82
	ENV DEPTH	FLT ENV DEPTH	✓	81
	A	ENV ATTACK	✓	83
	D	ENV DECAY	✓	84
	S	ENV SUSTAIN	-	85
	R	ENV RELEASE	✓	86
	CUTOFF	CUTOFF	✓	3
	RESONANCE	RESONANCE	✓	9
AMP	LEVEL	AMP LEVEL	✓	110
	TONE	TONE	✓	69
	A	AMP ENV SEL	-	89

*1: Select the target with the LFO 1 [ASSIGN] button, and adjust the intensity/depth with the [DEPTH] knob.

*2: Select the master with the LFO 2 [ASSIGN] button, and adjust the intensity/depth with the [DEPTH] knob.

Panel Device	Parameter Assign		Motion Assign X/Y	CC Assign
		[SHIFT] +		
MFX	ON/OFF		-	79
	TYPE		-	-
	CTRL1		✓	12
	CTRL2		✓	13
	CTRL3		✓	14
CHORUS	TYPE		-	
REVERB/ DELAY	TYPE Switch		-	(95)
	CTRL1		✓	44
	CTRL2		✓	45
	LEVEL *3		✓	94
	SEND *3		✓	91
VOICE	MONO	KEY MODE (MONO) *4	-	119
	PORTAMENTO	PORTA TIME	✓	5, 92
OTHER	VELOCITY			
	CHORD			
	HOLD			
	OCTAVE			
	TRANSPOSE			
	VOLUME			
	TEMPO			
	PITCH			
	MOD			1
MOTIONAL PAD	X-ASSIGN		-	(106)
	Y-ASSIGN		-	(107)
ARPEGGIO	ON	ARP SW	-	15
	MODE	MODE	-	70, 117
	SCALE	SCALE	-	80, 116

*3: When you set the CONTROL parameter "REV/DLY Knob MODE" to "SEND", the [LEVEL/SEND] knob operations are swapped.

*4: Confirm the KEY MODE by using the [MONO] button in combination with the [SHIFT] button + [PORTAMENTO] knob.

TONE Parameters

TONE

SH-101

* You may not be able to obtain the controller effect that you want with tones that use MFX Control.

Parameter	Value	Explanation
OSC		
OSC LFO MOD	0–100	Adjusts the depth at which the LFO modulates the OSC.
OSC RANGE	16', 8', 4', 2'	Specifies the oscillator's octave.
PULSE WIDTH MOD	0–127	PW MODE =MANUAL Adjusts the pulse width value.
		PW MODE =LFO/ENV Adjusts the depth of modulation.
PW MODE	Specifies the pulse width mode.	
	LFO	The pulse width is affected by the LFO.
	MANUAL	The pulse width is affected by PULSE WIDTH MOD.
	ENV	The pulse width is affected by ENV.
COMMON		
Tempo	20.00–300.00	Sets the tempo of the tone (including the arpeggio, motion and sequencer).
BEND PITCH	0–1500	Specifies the range of pitch change produced by pitch bend.
BEND FILTER	-63–0–+63	Specifies the range of filter change produced by pitch bend.
MODULATION LFO	-63–0–+63	Specifies the amount of LFO applied by modulation.
PORTA MODE	Turns portamento on/off. If this is on, the pitch will change smoothly from one note to the next-played note.	
	OFF	Regardless of the portamento time setting, portamento is not applied.
	ON	Portamento is always applied.
	AUTO	Portamento is applied only when you play legato (pressing the next key before completely releasing the previously-played key). This lets you use your playing technique to control portamento on/off.
PORTA TIME	0–1023	Adjusts the time over which the portamento pitch change occurs.
PORTA CRV	Specifies the pitch change curve for portamento.	
	ORIGINAL	Change according to the original curve of the model.
	LINEAR	Change on a linear curve.
	EXP1	Change in a non-linear curve (gentle slope).
	EXP2	Change in a non-linear curve (steep slope).
KEY MODE	Specifies how notes are sounded.	
	POLY	Polyphonic
	SOLO	Monophonic
	UNISON	Unison
	SL-UNISON	Monophonic unison
AFT LFO	-63–+63	Sets how much aftertouch changes the LFO intensity. * This is only enabled for products with aftertouch.
AFT FREQ	-63–+63	Sets how much aftertouch changes the low-pass filter intensity. * This is only enabled for keyboards with aftertouch.
AFT LEVEL	-63–+63	Sets how much aftertouch changes the tone volume. * This is only enabled for keyboards with aftertouch.

Parameter	Value	Explanation
PITCH DRIFT	0–255	Adjusts the slight pitch drift that occurs when notes are played on an analog synthesizer.
PARAM EXPANSION	OFF, ON	If this is “ON”, the range of change for LFO RATE, CUTOFF, RESONANCE, and FILTER ENV DEPTH is wider than on the original model.
CONDITION	0–100	Simulates the changes that occur as a unit ages.
Chord Switch	OFF, ON	Turns the chord memory function on/off.
Hold Switch	OFF, ON	While this is “ON”, the notes you play keep sounding even after you take your fingers off the keyboard.
Category	Selects the tone’s category.	
	No Assign–Vocoder (*) The GAIA-2 does not have a built-in vocoder.	

MIX

PW LEVEL	0–255	Adjusts the volume of the pulse wave.
SAW LEVEL	0–255	Adjusts the volume of the sawtooth wave.
SUB OSC LEVEL	0–255	Adjusts the volume of the sub oscillator.
SUB OSC	Specifies the SUB OSC type.	
	1OCT DN	One octave lower
	2OCT DN1	Two octaves lower
	2OCT DN2	Two octaves lower (small pulse width)
NOISE LEVEL	0–255	Adjusts the noise volume.

LFO

LFO RATE	0–1023	Specifies the speed of the LFO cycle.
LFO WAVEFORM	TRI, SQR, S&H	Selects the waveform of the LFO.

FILTER

VINTAGE FLT TYPE	R, M, S	Selects one of three response curves, each modeling the LPF of an analog synthesizer of the past.
CUTOFF	0–1023	Specifies the cutoff frequency of the low-pass filter. The frequency region above the cutoff frequency is cut, producing a more mellow tonal character.
RESONANCE	0–1023	Boosts the region of the filter’s cutoff frequency. Higher values produce a stronger result, giving the sound a distinctively synthesizer-like character.
FLT ENV DEPTH	-1023–+1023	Adjusts the amount by which the cutoff frequency is controlled by the envelope.
FILTER MOD	0–100	Adjusts the amount by which the LFO modulates the cutoff frequency.
FLT KEY FOLLOW	0–200	Varies the filter’s cutoff frequency according to the position of the key.

ENV

ENV MODE	Specifies what causes the envelope to attack.	
	GATE+TRIG	Attack each time a key is pressed.
	GATE	Attack when a key is pressed anew. No attack when playing legato.
	LFO	Attack repeatedly at each cycle of the LFO as long as the key is held.
ENV ATTACK	0–1023	Specifies the ENV Attack time.
ENV DECAY	0–1023	Specifies the ENV Decay time.
ENV SUSTAIN	0–1023	Specifies the ENV Sustain level.
ENV RELEASE	0–1023	Specifies the ENV Release time.

AMP

AMP LEVEL	0–127	Adjusts the volume of the tone.
AMP TONE	-63–0–+63	Adjusts the tonal character.

Parameter	Value	Explanation
AMP ENV SEL	ENV F&A, G-AMP	Specifies whether the volume is controlled by the ENV (ENV F&A) or stays at a fixed volume as long as the key is held down (G-AMP).
CONTROL		
Pedal Func	OFF, MODULATION, HOLD1, EXPRESSION, VOLUME, PAN, BEND DOWN, BEND UP, HOLD SW, MONO SW, MFX SW, CHO LEVEL, REV LEVEL, REV SEND, BEND MODE, ARP SW, ARP SHUFFLE, ARP DURATION, START/STOP, TAP TEMPO, TONE DOWN, TONE UP	Specifies the function assigned to the pedal connected to the PEDAL jack.
Pedal Pole	STANDARD, REVERSE	Specifies the polarity of the pedal connected to the PEDAL jack.
Keyboard Velocity	REAL, FIXED	Specifies whether the velocity value changes according to the actual strength of your playing (REAL) or is always a fixed velocity value regardless of how you play (FIXED).
Key Fixed Velocity	1–127	Specifies the velocity value when Keyboard Velocity is “FIXED”.
REV/DLY Knob Mode	LEVEL, SEND	Switches the functions of the REVERB/DELAY [LEVEL] knob and the [SEND] knob (+ SHIFT operation).
FX Order	MFX->CHO->REV, MFX->REV->CHO, CHO->MFX->REV, CHO->REV->MFX, REV->MFX->CHO, REV->CHO->MFX	This sets the routing for the MFX, CHO and REV/DLY.

The effect types you can select for MFX are based on the specifications of the Model Expansion (This differs from the specifications of the GAIA-2's original sound module). See the “GAIA-2 Roland Cloud User's Guide” (Roland website) for details on the MFX types you can select.

The parameters for CHO and REV are the same as for the original GAIA-2 sound module.