



Darkglass® Electronics

Your vision, our gear.

CREATIONS

DEALERS

SUITE

APPAREL



Microtubes X 900 Manual

900W Bass Amplifier

[Specs](#)

[Block Diagram](#)

[Warning](#)

[Warranty](#)

Specs

Controls

Input: Use this jack to connect your instrument via a standard 1/4" mono cable.

Passive/Active: Use this push-button switch to change from passive to active mode. If your bass is active it can have a hotter signal, making the amp distort earlier (feel free to use if such additional distortion is desired).

X: Use this push-button to turn on or off the Microtubes X Engine which allows you to compress and distort your bass signal in two separate bands, solidifying the clean low end and distorting the highs to taste from articulate to aggressive. The Microtubes X Engine operates before the EQ section.

Clean Comp: Use this push-button switch to activate the compressor circuit for the clean channel.

Vol (Clean Comp): Sets the level of the clean channel when the compressor is engaged.

HPF (High Pass Filter): Controls the cutoff frequency of

the high pass filter which is applied before the clean signal is fed to the distortion circuit. Ranging from 100 Hz (for thicker, fuzzier saturation) to 1 kHz (for ultra-sharp definition).

Drive: Sets the amount of distortion for the high pass side.

Mix: Controls the blend between the compressed lows and the distorted highs.

LPF (Low Pass Filter): Controls the cut-off frequency of the low pass filter which is applied before the clean signal is fed to the compression circuit. Ranging from 50 Hz (for only sub-bass) to 500 Hz (to preserve some clean mids).

Comp: Controls the amount of compression for the low band when X is activated. Both threshold and makeup gain are controlled to maintain a constant level. This control is also used to control the amount of compression when the compressor is enabled for the clean signal. The clean comp is full-range.

Level: Sets the output volume of the X channel.

Bass: ± 12 dB @ 80 Hz.

Mids: ± 12 dB at 250, 500, 1.5k and 3 kHz.

Treble: ± 12 dB @ 3 kHz.

Master: Sets the overall volume of the unit.

Mute: Use this push-button to mute the amplifier.

Technical Specifications

Input Impedance: 1.1 M Ω

Minimum Load Impedance: 2.5 Ω

Maximum Power Output: 900 W RMS @ 4 Ω (1 kHz full blast, 2 min. max) 20% THD, 450 W RMS @ 8 Ω

Power Amp Input (Return) Impedance: 100 k Ω

Power Amp Input (Return) Level: 2 Vrms (max before 1% THD)

Pre-Amp Output (Send) Impedance: 1 k Ω

Pre-Amp Output (Send) Level (max): 2.2 Vrms (max before 1% THD)

Maximum Power Consumption: approx. 700 VA

Cooling: Forced-air cooled

AC Input Power: 100–250 VAC

AC Frequency: 50/60 Hz



Dimensions

Width: 26.7 cm / 10.5"

Length: 25.5 cm / 10"

Height: 7 cm / 2.75"

Weight: 2.9 kg / 6.39 lb

Block Diagram

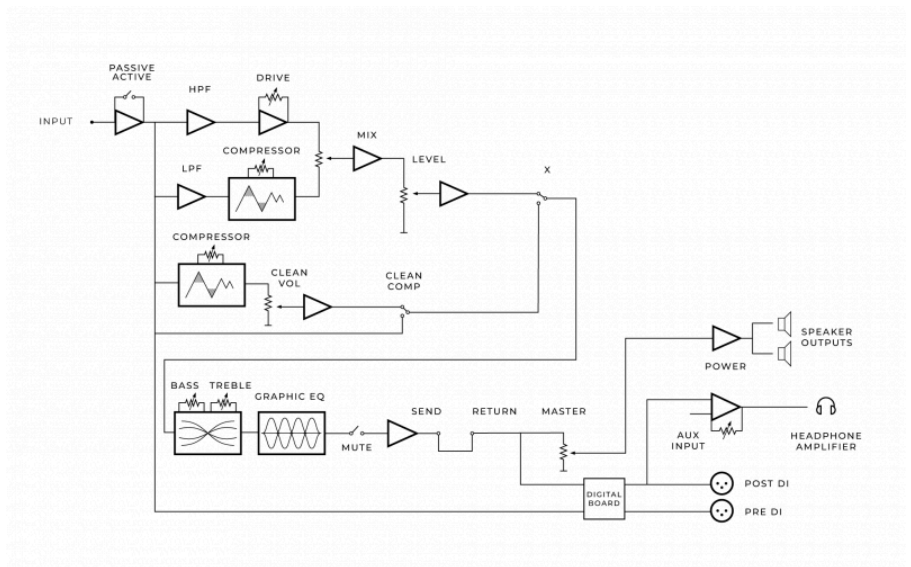

Warning

- No user serviceable parts inside the amplifier. Do not open the amp.
- Never use the amp in a high moisture environment or near liquids.

- The Microtubes X 900 can deliver more than 115 dB of power. Exposure to this level of sound can damage your hearing. Use proper hearing protection if you will be exposed.
- The Microtubes X 900 can deliver more than 900 W RMS with a 4 Ω load. Be sure that your speaker cabinet is able to deliver that power.
- Do not cover the vent holes. The fan and vent holes are part of the cooling system of the amp. Covering the vent holes can damage the power amp by overheating it.
- Don't use an instrument cable as a speaker cable. An instrument cable is not designed to deliver the type of power signals sent from the amplifier to the speaker.

Troubleshooting

- The button controls do not react: check if the footswitch is connected. If you do not want to use the footswitch, you have to unplug the cable from the rear panel of the amp.
- The amp does not turn on: check if the power cable is connected and if you have power from the wall.
- The sound is low: check your speaker cable. Never use an instrument cable.
- The sound is distorted or too high: check if the passive/active switch matches your bass.

Warranty

Please register for your warranty at <http://mypedal.darkglass.com>. The Microtubes X 900 is under warranty to the original owner for a period of two years against manufacturing defects in the country where the product was originally purchased.

If you experience a problem with the unit, please contact support@darkglass.com to receive a Return Authorization number or for information on the nearest authorized repair

center. A copy of your original receipt must be included with all warranty repairs. You are responsible for all shipping charges. The unit must be shipped to us freight prepaid. We will return the unit freight collect.

Darkglass Electronics Oy is not responsible for shipping damage either to or from our service center. Claims must be filed with the carrier.

Darkglass® and Microtubes® are registered trademarks of Darkglass Electronics Oy.



[PRIVACY POLICY](#)

[CAREERS](#)



DARKGLASS is a registered trademark in the U.S., number 4,616,801, owned by Darkglass Electronics Oy.

Designed by Revolve Studio