

Grp Synthesizer® A1 - Owner's Manual

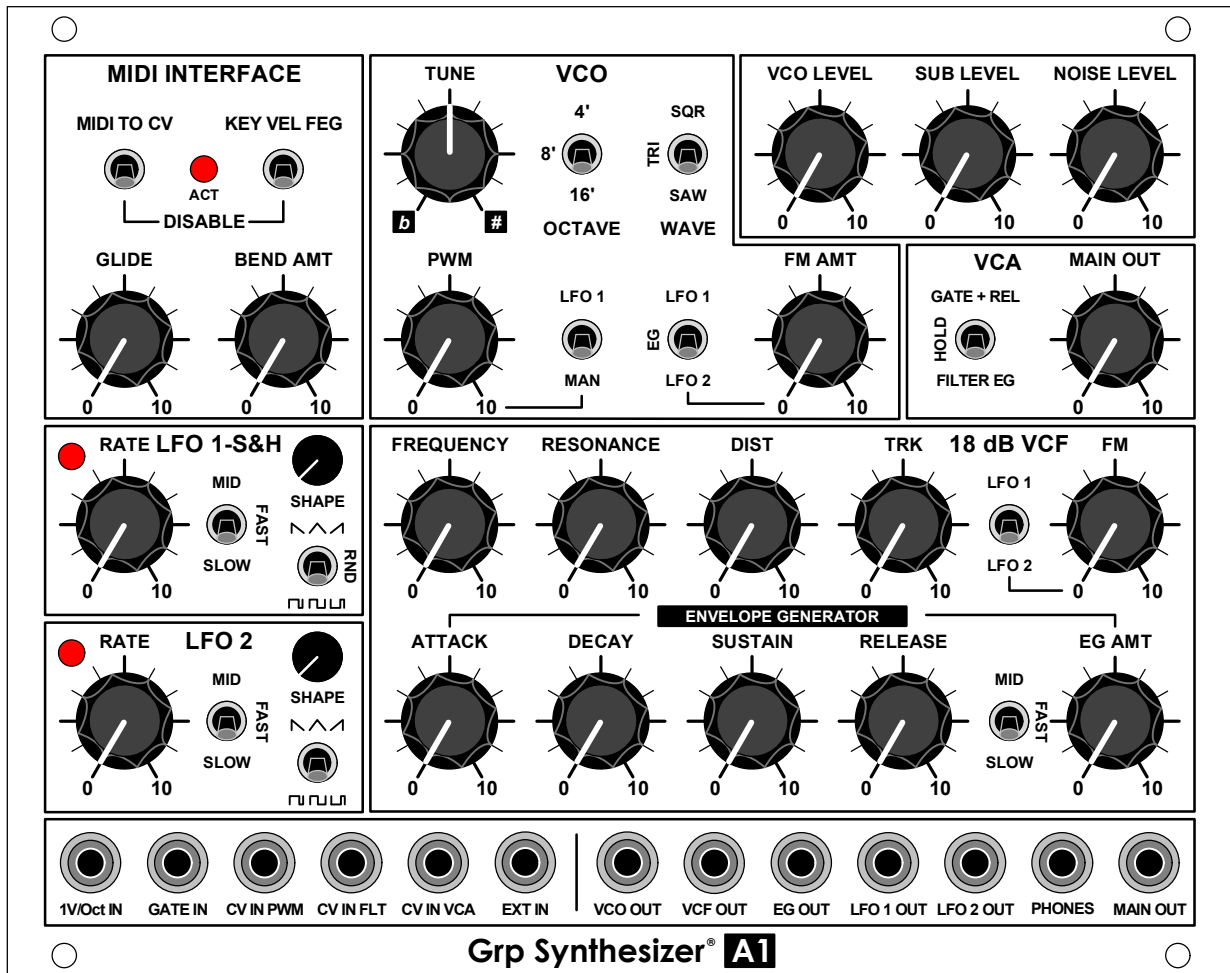

This page was intentionally left blank

Contents

1. Welcome
2. Safety Rules
3. Connections
- 3.1. MIDI Data Received
- 3.2. Choosing MIDI Channel
4. The Grp A1 Synthesizer
 - 4.1. MIDI INTERFACE
 - 4.1.1. MIDI TO CV ENABLE
 - 4.1.2. KEY VEL FEG ENABLE
 - 4.1.3. GLIDE
 - 4.1.4. BEND AMT
 - 4.2. VCO
 - 4.2.1. VCO - Panel Controls
 - 4.2.1.1. TUNE
 - 4.2.1.2. OCTAVE
 - 4.2.1.3. WAVE
 - 4.2.1.4. PWM
 - 4.2.1.5. LFO1/MAN
 - 4.2.1.6. LFO1 / EG / LFO2
 - 4.2.1.7. FM AMT
 - 4.2.2. VCO - Audio and Control Connections
 - 4.2.2.1. 1v/Oct IN
 - 4.2.2.2. CV IN PWM
 - 4.2.2.3. VCO OUT
 - 4.3. MIXER
 - 4.3.1. MIXER - Panel Controls
 - 4.3.1.1. VCO
 - 4.3.1.2. SUB
 - 4.3.1.3. NOISE
 - 4.3.2. MIXER - Audio Connections
 - 4.3.2.1. EXT IN
 - 4.3.3. MIXER - Working with internal Jumpers
 - 4.4. 18 dB VCF
 - 4.4.1. 18dB VCF - Panel Controls
 - 4.4.1.1. FREQUENCY
 - 4.4.1.2. RESONANCE
 - 4.4.1.3. DIST
 - 4.4.1.4. TRK
 - 4.4.1.5. FM
 - 4.4.1.6. LFO 1/LFO2
 - 4.4.1.7. EG AMT
 - 4.4.2. 18 dB VCF - Audio and Control Connections
 - 4.4.2.1. CV IN FLT
 - 4.4.2.2. VCF OUT
 - 4.5. ENVELOPE GENERATOR
 - 4.5.1. ENVELOPE GENERATOR - Panel Controls
 - 4.5.1.1. ATTACK
 - 4.5.1.2. DECAY
 - 4.5.1.3. SUSTAIN
 - 4.5.1.4. RELEASE
 - 4.5.1.5. MID / FAST / SLOW
 - 4.5.2. ENVELOPE GENERATOR - Control Connections
 - 4.5.2.1. GATE IN
 - 4.5.2.2. EG OUT
 - 4.6. VCA
 - 4.6.1. VCA - Panel Controls
 - 4.6.1.1. GATE+REL / HOLD / FILTER EG
 - 4.6.1.2. MAIN OUT
 - 4.6.2. VCA - Audio and Control Connections
 - 4.6.2.1. CV IN VCA
 - 4.6.2.2. MAIN OUT
 - 4.6.2.3. PHONES
 - 4.7. LFO 1 - S&H
 - 4.7.1. LFO 1- S&H - Panel Controls
 - 4.7.1.1. RATE
 - 4.7.1.2. MID/FAST/SLOW
 - 4.7.1.3. SHAPE
 - 4.7.1.4. TRIANGLE / RND / PULSE
 - 4.7.2. LFO 1 - S&H - Control Connections
 - 4.7.2.1. LFO 1 OUT
 - 4.8. LFO 2
 - 4.8.1. LFO 2 - Panel Controls
 - 4.8.1.1. RATE
 - 4.8.1.2. MID / SLOW / FAST
 - 4.8.1.3. SHAPE
 - 4.8.1.4. TRIANGLE / PULSE
 - 4.8.2. LFO 2 - Control Connections
 - 4.8.2.1. LFO 2 OUT
5. FRONT PANEL CONNECTIONS
 - 5.1. INPUTS
 - 5.2. OUTPUTS
6. REAR PANEL CONNECTIONS

1. Welcome

Thank you for purchasing the Grp A1 Synthesizer. The instrument is equipped with a powerful audio oscillator, a sub oscillator and a noise generator that together with a possible external signal can be treated with an aggressive resonant low-pass filter at -18 dB / Oct with personal and recognizable sound.

It is possible to use an Envelope Generator, a pair of Low Frequency Oscillators (with Sample & Hold function) to control the behavior of the synthesizer.

Grp A1 Synthesizer, which manages MIDI and analog CV / Gate, can be powered with any USB Type-C Power Pack or USB port capable of delivering +5V @ 2.5A.

NOTE: While Grp A1 Synthesizer has an effective absorption of 750 mA, some cheap USB power supplies may not guarantee - despite what is declared by the respective manufacturers - sufficiently solid energy to feed synthesizer on a regular basis. The same could happen with the USB ports of poorly energy-equipped laptops.

If necessary, it is recommended to use a powered USB hub, using it between the laptop and the Grp A1 Synthesizer.

Under no circumstances should Grp Synthesizer be held responsible for any malfunctions.

2. Safety Rules

Please read the instructions here carefully. You must always follow the safety rules when working with electrical equipment, for your health and that of your precious equipment.

OPERATING CONDITIONS

- Do not use this synthesizer in potentially hazardous environments and near water (swimming pools, bathrooms, sinks, places with a lot of humidity).
- Never use synthesizer in very dusty and dirty places.
- Never place the synthesizer near heat sources, such as radiators or stoves.
- Do not expose the instrument directly to sunlight. Ultraviolet rays can change colors.
- Do not expose the appliance to strong mechanical vibrations.
- Do not throw away the original packaging: they can be useful to safely ship the unit.

POWERING

- Your Grp A1 synthesizer can be powered by any Power Bank or USB power supply capable of delivering +5V voltage (according to USB standards) with 2.5 A.
See what already reported at section 1. Welcome on page 4 of this Owner's Manual.
- The unit can be powered by a USB port on the computer; in this case, you can also take advantage of MIDI over USB capabilities.
See what already reported at section 1. Welcome on page 4 of this Owner's Manual.
- Disconnect the power supply if you do not have to use the appliance for a long time.
- When disconnecting the power, grab the Power Bank or power supply securely, avoiding pulling the cord.

OPERATIONS

- Even if you are a rockstar, NEVER place bottles or glasses with liquids near the synthesizer.
- The synthesizer must be placed on a solid surface.
- The synthesizer can produce VERY loud sounds; Avoid hurting your ears.

CORRECT USE OF THE INSTRUMENT

- This synthesizer is designed exclusively for the production of audio signals. Any other use is prohibited and violates the warranty of Grp Synthesizer. Grp Synthesizer is in no way responsible for damage caused by improper use of the device.

While Grp A1 Synthesizer has an effective absorption of 750 mA, some cheap USB power supplies may not guarantee - despite what is declared by the respective manufacturers - sufficiently solid energy to feed synthesizer on a regular basis. The same could happen with the USB ports of poorly energy-equipped laptops.

If necessary, it is recommended to use a powered USB hub, using it between the laptop and the Grp A1 Synthesizer.

Under no circumstances should Grp Synthesizer be held responsible for any malfunctions.

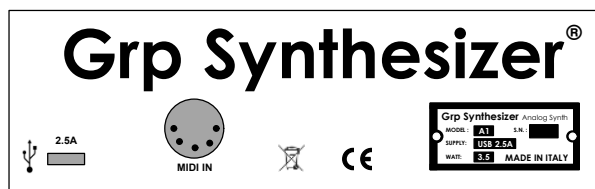

3. Connections

After obtaining a USB Type-C compatible power supply capable of delivering +5V @ 2.5A, connect it on the rear panel to the 2.5A input marked with the USB symbol. The effective synthesizer absorption is 750 mA. See what already reported on Section 1. Welcome in page 4 of this Owner's Manual.

The connector supports MIDI-Over-USB protocol with Mac/PC. The synthesizer is seen by the computer as a Grp A1 peripheral and can execute Note On/Off & Pitch Bend commands sent by your DAW on the instrument's MIDI Channel (see below).

If necessary, use the MIDI IN port to drive the Grp A1 with a MIDI Master Keyboard or other external controller equipped with MIDI 5-pin DIN.

Alternatively, you can control the instrument using the analog connections on the lower end of the front panel:

- 1V/Oct IN. Connect to this input the necessary CV voltage drive the pitch of the VCO internal oscillator.
- GATE IN. Connect to this input the GATE voltage (0/+5V) necessary to activate and articulate the internal Envelope Generator.

Connect the MAIN OUT output to your amplification system. The MAIN OUT command (in the VCA section) controls the audio out level.

Although a 1/8" TRS cable can be used, the instrument is designed to work with unbalanced TS-Tip / Sleeve 1/8" connections.

You can use the PHONES output to listen to the instrument on headphones. Again, the MAIN OUT command controls the listening volume.

3.1. MIDI Data Received

Grp A1 synthesizer receives MIDI data for:

- Note On/Off with Key Velocity (the dynamic controls the Filter Envelope Amount).
- Pitch Bend.

3.2. Choosing MIDI Channel

On powering on, check the position of the MIDI TO CV switch in the MIDI INTERFACE module:

- **Power on with MIDI TO CV switch in DISABLE position.** If the switch is in the DISABLE (down) position, the ACT LED blinks indicating that the instrument is waiting to receive any message sent over the MIDI Channel to tune to.

To tune the synthesizer to the desired MIDI channel, you need:

- Return the MIDI TO CV switch to the ENABLE (up) position for normal operation.
- Press a MIDI note or send any MIDI message from the control source; the ACT LED blinks faster indicating the reception of MIDI data and then turns off waiting for the normal codes received.

Now, the Grp A1 is tuned to the desired MIDI channel and can be used normally.

- **Power on with MIDI TO CV switch in ENABLE position.** If the instrument is turned on with the switch in the ENABLE (upward) position, the machine remains set to the previously selected MIDI Channel. The ACT LED lights up only when the instrument receives MIDI data, indicating the MIDI reception activity of the received commands.

NYou do not need to repeat the MIDI tuner procedure every time you turn on the instrument.

- If you want **to change MIDI Channel with the synthesizer already turned on**, simply switch the MIDI TO CV switch first to the DISABLE position (down) and then to the ENABLE position (upwards).
The ACT LED starts blinking indicating that the instrument is waiting to receive a new MIDI Channel. After the Channel is assigned, the ACT LED stops blinking and lights up only to indicate the reception of MIDI traffic in progress.

4. Grp A1 Synthesizer

The Grp A1 monophonic synthesizer can be used as a stand-alone musical instrument or can be used to filter external signals within the Low Pass 18dB VCF resonant circuit. The three internal audio sources (VCO, SUB and NOISE) guarantees timbre power and ease of use. With the two Low Frequency Oscillators - LFOs (the first, integrates an S&H Sample & Hold) and with the ADSR Envelope Generator, it is possible to sculpt the cyclic or transient modulation behavior.

It is possible to obtain independent articulations of VCF and VCA by choosing for the latter one of the behaviors FILTER EG, GATE + REL, HOLD.

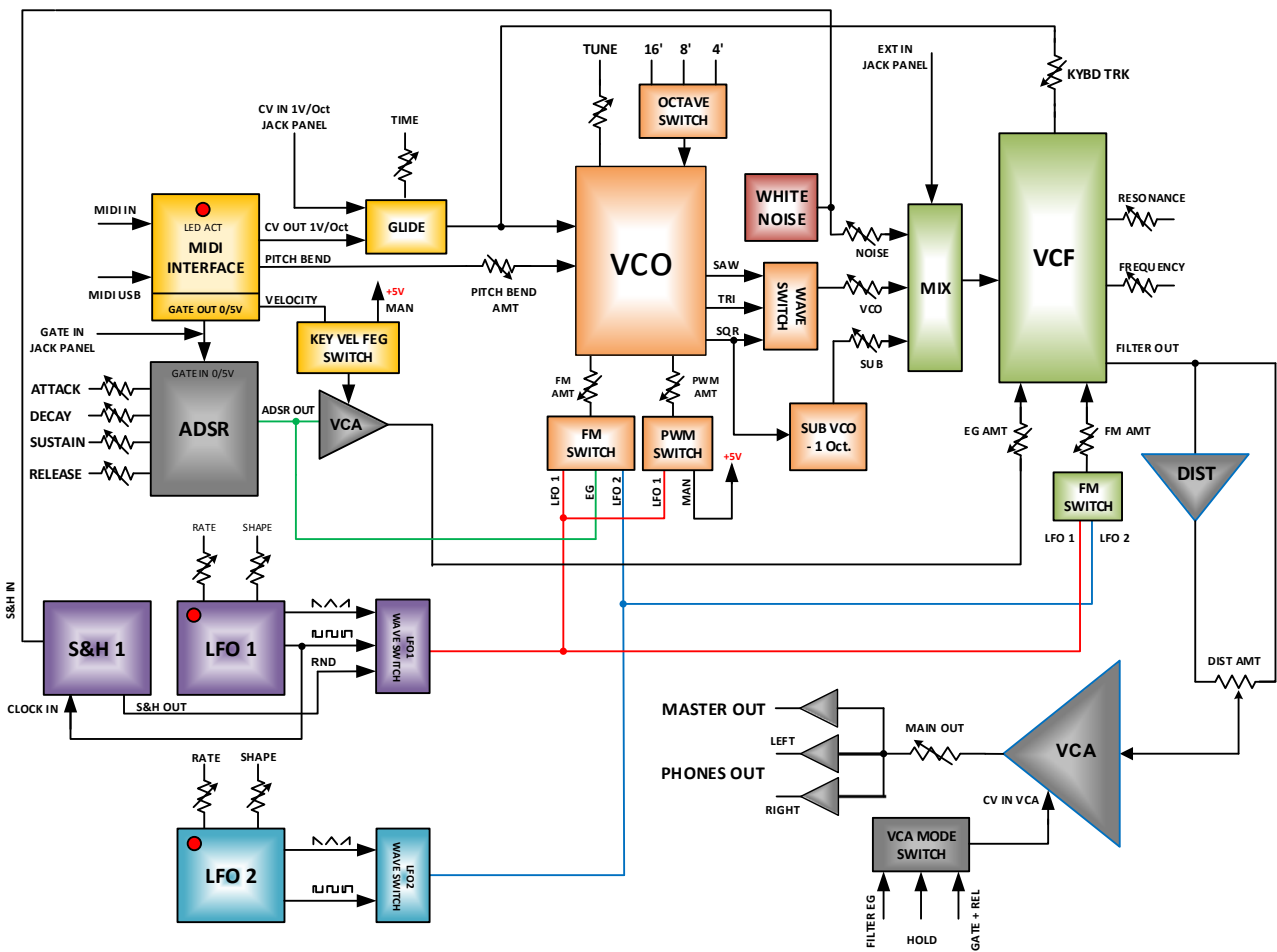

The instrument can be removed from your cabinet to be easily installed in any EuroRack modular system; it is possible to power it using the normal flat cables supplied with EuroRack systems.

Inside, on the back of the components board, you can locate the Jumper with which you change the sensitivity of the EXT INPUT.

Below is a description of the individual controls and connections available for each section of the tool.

4.1 MIDI INTERFACE

The MIDI INTERFACE section manages the reception and interpretation of MIDI codes that reach the A1 synthesizer indifferently on the DIN MIDI IN or USB connector on the rear panel.

4.1.1. MIDI TO CV

The switch enables or disables MIDI reception; reception is active with the switch in the ENABLE (upward) position.

In the other case, when the switch is in the DISABLE position, the instrument can only be controlled via CV/Gate.

The ACT LED lights up in response to receiving a MIDI code. Please refer to section 2.2. CHOOSE THE MIDI CHANNEL to check the possible operating conditions of the LED and their meanings.

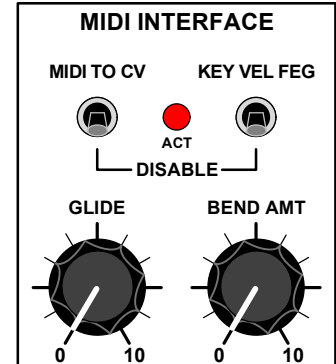

4.1.2. KEY VEL FEG

The command activates or disables the reception of the MIDI Key Velocity applied to the control of the Filter Envelope Amount; in this way, by varying the executive dynamics, it is possible to obtain a greater or lesser opening of the Low pass Filter.

4.1.3. GLIDE

Adjusts the Glide Time value applied to CV 1V/Oct and/or notes received via MIDI/USB. Time Range is between 0 and 1.5 Sec/Oct.

4.1.4. BEND AMOUNT

The command sets the the MIDI Pitch Bend range. The value is between 0 and 12 semitones in the positive and negative direction.

4.2. VCO

The VCO (Voltage Controlled Oscillator) is the main sound source of the synthesizer; It produces different waveforms (with a different harmonic content) and can be tuned to the desired frequency. It is possible to modulate the symmetry of the square wave and the pitch of the oscillator. The VCO oscillator signal can be enhanced using the available SUB Oscillator.

4.2.1. VCO - Panel Controls

Below is a description of the panel commands.

4.2.1.1 TUNE

Controls the oscillator's pitch.

The command has range equal to +/-1 octave (with zero in the center position) and its value is added to control received through MIDI IN / USB or through analog connection 1V / Oct IN.

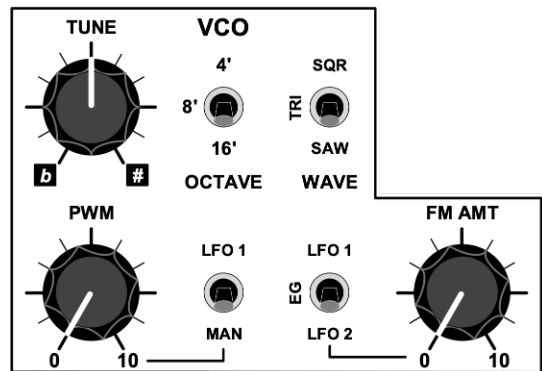

4.2.1.2. OCTAVE

Adjust the octave of the VCO by choosing between 16' (an octave lower than the note played), 8' (the same octave as the note played), 4' (one octave above the note played).

4.2.1.3. WAVE

Selects the oscillator's waveform. SAW, TRI and SQR waves are available; the latter can be adjusted in symmetry/pulse width/duty cycle using PWM control (see below).

4.2.1.4. PWM

The control sets the square/pulse wave symmetry. Depending on the position chosen with the LFO1/MAN switch, the control will act as a true symmetry value between 0 and 50% (switch in MAN position) or as Amount for the modulation produced by the Low Frequency Oscillator LFO 1 (switch in position LFO 1).

The PW-Pulse Width symmetry can also be controlled through an external modulation signal connected to the unprocessed CV input in PWM.

4.2.1.5. LFO1 / MAN

The switch allows you to choose which modulation source is applied to the PW-Pulse Width symmetry of the square wave. In LFO position 1, the first Low Frequency Oscillator (and integrated S&H functions) will act on symmetry; in the MAN(ual) position, it becomes possible to adjust the symmetry value by hand acting directly on the PWM rotary control.

4.2.1.6. LFO1 / EG / LFO2

The switch chooses the modulation source that is applied to the pitch of the oscillator into range set through FM AMOUNT control. With the three switch positions, you can choose: LFO 1 (the modulating signal produced by LFO 1 - and internal S&H), EG (the ADSR Envelope Generator), LFO 2 (the modulating signal produced by LFO 2).

4.2.1.7. FM AMOUNT

The control sets the modulation index applied to the oscillator frequency.

4.2.2. VCO - Audio and Control Connections

Below, the description of the connections (audio and control) on the front panel related to the VCO oscillator.

4.2.2.1. 1v/Oct IN

The connection is designed to receive 1V/Oct control voltages from keyboards, sequencers or other external CV sources.

4.2.2.2. CV IN PWM

The connection allows remote control of the PW symmetry of the SQR wave. The control input is not processed, so any attenuations on the external control signal should be provided externally.

4.2.2.3. VCO OUT

The connection makes the audio signal produced by the oscillator available for any external use (or for audio rate modulation); the signal is not attenuated and comes out with a 10V p-p level.

4.3. MIXER

The MIXER receives and balances the three signals simultaneously available in the A1 synthesizer.

4.3.1. MIXER - Panel Controls

Below, the description of the MIXER panel commands.

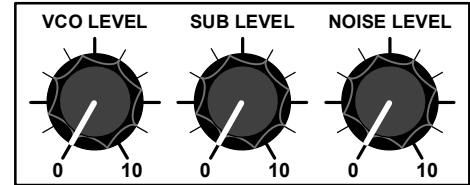

4.3.1.1. VCO LEVEL

The control adjusts the output volume of the Voltage Controlled Oscillator. If you choose SQR wave and the PWM symmetry of the SQR wave is set on extreme values, the signal produced by the oscillator may not be audible.

4.3.1.2. SUB LEVEL

The control sets the volume of the **Square wave** produced by frequency division at a low octave distance from the VCO signal.

4.3.1.3. NOISE LEVEL

The control sets the volume of the **White Noise Generator** available into A1 Synthesizer.

4.3.2. MIXER - Audio Connections

Below, the description of the audio connections related to the MIXER present on the front panel of the instrument.

4.3.2.1. EXT IN

It is possible to exploit a fourth signal coming from the outside and possibly connected to the EXT IN connection. In this case, it is necessary to provide externally for its volume adjustment.

Inside the instrument, on the back of the components board, there is a Jumper for select the sensitivity of the EXT IN connection.

- *No Jumper. The circuit accepts signals up to 10V p-p.*
- *Jumper in MID position. The circuit accepts signals up to 5V p-p.*
- *Jumper in HI position. The circuit accepts signals up to 1V p-p.*

Grp A1 Synthesizer is factory shipped with Jumper Jumper in MID position.

4.4. 18dB VCF

The 18dB VCF - Voltage Controlled Filter allows you to sculpt in real time the harmonic content of the sound generated by the synthesizer. When controlled with the transient ADSR Envelope Generator, or under the cyclic control of the LFO - Low Frequency Oscillator, it gives expressiveness and intensity to the sound. The 18dB circuit offers a different timbre, less dark than to the classic 24 dB and, at the same time, produces a more acidic signal than the equally classic 12 dB if adjusted to high Resonance values.

4.4.1. 18dB VCF - Panel Controls

Below, the description of the 18 dB Filter commands on the operation panel.

The picture also reproduce, for convenience, the commands of the ADSR Envelope Generator which we will discuss later.

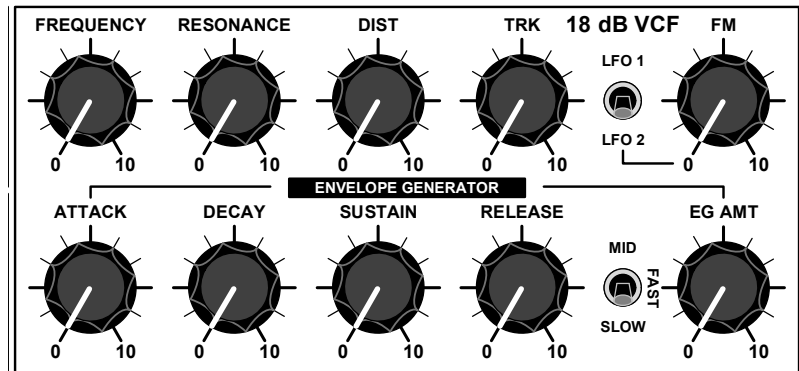

4.4.1.1. FREQUENCY

Adjusts the Cutoff Frequency of the filter, which defines the limit of the high harmonics let through. In addition to the controls received from the ADSR Envelope Generator and the FM by LFO 1/LFO 2, it is possible to control the FREQUENCY through the Keyboard Tracking managed with the TRK command (processed based on what was received via MIDI and / or the voltage received at the analog input 1V / Oct IN). Still, it is possible to connect an external control source (unprocessed) using the FLT CV input.

As you can imagine, if you exaggerate with the simultaneous amount of control voltage, the FREQUENCY command will be difficult to manage.

4.4.1.2. RESONANCE

It sets the amount of signal in recirculation making progressively more emphasized and then acid the timbre produced by the filter itself. Extreme values of RESONANCE can bring the filter into self-oscillation generating a sine wave of frequency equal to the value of Cutoff FREQUENCY.

In this case, it is possible to play the RESONANCE using an accurate adjustment of the TRK control together with the MIDI values and the external CV CONTROL IN FLT.

4.4.1.3. DIST

Adjusts the amount of saturation applied to the output audio signal to the filter.

4.4.1.3. TRK

Adjust the Keyboard Tracking applied to the Cutoff FREQUENCY. In position 10, the control respects the 1v/Oct ratio, allowing the tempered execution with the RESONANCE possibly brought in self-oscillation.

4.4.1.4. FM

The command adjusts the intensity of the frequency modulation applied to the Cutoff FREQUENCY value. You can choose two control sources using the nearby LFO 1 / LFO 2 switch. With the switch in the LFO 1 position (upwards), you choose the first Low Frequency Oscillator LFO 1 as the control source; with the switch in the LFO 2 (downward) position, the second Low Frequency Oscillator LFO 2 is chosen as the control source.

4.4.1.5. LFO 1 / LFO 2

Allows the choice of the Low Frequency Oscillator - LFO 1 or 2 as the modulation source applied to the FREQUENCY of the filter.

4.4.1.6. EG AMT

Governs the amount of ADSR Envelope Generator applied to the Cutoff FREQUENCY. In this way, it is possible to change the effectiveness in the articulation of sound. If EG AMT is at maximum and Cutoff FREQUENCY is also at maximum, the filter - simply - does not close.

4.4.2. 18 dB VCF - Audio and Control Connections

Below, the description of the control and audio connections related to the 18 dB VCF filter on the front panel of the synthesizer.

4.4.2.1. CV IN FLT

It receives the possible external control source applied to the Cutoff FREQUENCY. The control signal, unprocessed, must be attenuated at the source.

4.4.2.2. VCF OUT

Is the audio output of the 18 dB VCF module. In this way, it is possible to use Grp A1 as a sophisticated processor for static or dynamic audio processing through modulation.

4.5. ENVELOPE GENERATOR

The Envelope Generator produces the transient control signal necessary for the articulation of the filtering over time. Its signal can also be used (but not only) to control the level of the VCA Amplifier.

La grafica riproduce, per comodità, anche i comandi relativi al Filtro 18dB VCF.

4.5.1. ENVELOPE GENERATOR

-

Panel Controls

Below is a description of the panel commands available for the ADSR Envelope Generator.

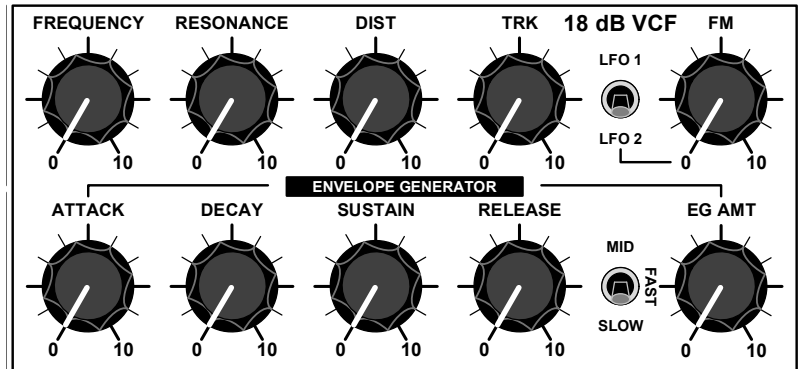

4.5.1.1. ATTACK

Adjusts the Attack time required to go from the minimum value to the maximum control value. Depending on the FAST, MID or SLOW position of the panel switch, the attack time varies between 0 and 1 second, 2.5 seconds or 8 seconds.

4.5.1.2. DECAY

Adjusts the Decay time required to go from the maximum value reached at the end of ATTACK to the Sustain level. If the value of Sustain is at its maximum, the Decay has no effect. The duration is between 0 and 3 seconds, or 15 seconds or 40 seconds depending on the FAST, MID or SLOW position of the panel switch.

4.5.1.3. SUSTAIN

Adjusts the level of Sustain that is extended until the Gate Off.

4.5.1.4. RELEASE

Adjusts the Release time required to move from the Sustain level (if nonzero) to the minimum level corresponding to the end of the Envelope trajectory. The duration is between 0 and 3 seconds, or 15 seconds, or 40 seconds, depending on the FAST, MID, or SLOW position of the panel switch.

4.5.1.5. MID / FAST / SLOW

The times of Attack, Decay and Release are adjustable in three excursion fields through this switch. You can choose between MID intermediate travel (top switch), FAST (middle position switch) or SLOW (low position switch).

4.5.2. ENVELOPE GENERATOR - Control Connections

Below, the description of the control connections of the ADSR Envelope Generator present on the synthesizer control panel.

4.5.2.1. GATE IN

The connection accepts the analog voltage **0/+5V** necessary to trigger the Envelope Generator.

4.5.2.2. EG OUT

The connection provides the control signal processed by the ADSR Envelope Generator.

The voltage is 0/+5V.

4.6. VCA - Voltage Controlled Amplifier

The Voltage Controlled Amplifier allows you to control the volume of the signal produced by the A1 synthesizer over time. You can choose three different control sources with the FILTER EG / HOLD / GATE + REL switch; moreover, it is possible to control the level of the Amplifier from the outside through voltage connected to the CVI input in VCA.

4.6.1. VCA - Panel Controls

Below, the description of the panel commands that govern the operation of the VCA.

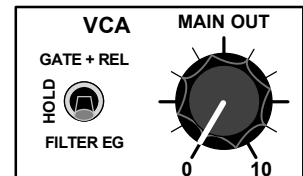

4.6.1.1. GATE+ REL / HOLD / FILTER EG

Allows you to choose between three possible control sources inside the A1 synthesizer.

- With the switch in the FILTER EG position, the Amplifier is controlled by the ADSR Envelope Generator which also opens the VCF.
- With the switch in the HOLD position, the Amplifier is *always open* and the sound - compatible with the other settings of VCO, MIXER and VCF - never ends.
- With the switch in the GATE + REL position, the Amplifier opens with the Gate On, remains at the maximum level as long as the Gate voltage persists and, at the Gate Off, uses the Release time programmed in the ADSR Filter Envelope as long as this makes functional sense.

4.6.1.2. MAIN OUT

Adjust the output volume of the instrument.

4.6.2. VCA - Connessioni di controllo e audio

Below is the description of the control and audio connections on the A1 synthesizer panel.

4.6.2.1. CV IN VCA

Input for the control signal applied to the level of the Voltage Controlled Amplifier. A voltage of 0V closes the Amplifier; the maximum receivable voltage is +5V.

To control the VCA only with an external CV voltage, it is necessary not to activate the Gate (indifferently, analog or MIDI) and the Filter Envelope. With the VCA only under external voltage, it is recommended to limit the controls to only 1V/Oct management for the pitch of the oscillator, without using MIDI.

4.6.2.2. MAIN OUT

Is the audio output of the synthesizer.

4.6.2.3. PHONES

Is the output for listening to headphones, its volume is always regulated by the MAIN OUT command.

4.7. LFO 1 - S&H

The module includes a cyclic modulation source LFO 1 - Low Frequency Oscillator and a Sample & Hold, which produces random control voltages. As in higher-end GRP instruments, it is possible to adjust the symmetry of triangular and square waves obtaining ramp - triangular - sawtooth and impulsive - square - impulsive behaviors.

Signal LED makes the selected frequency visible.

4.7.1. LFO 1 - S&H - Panel Controls

Below is a description of the form's panel controls..

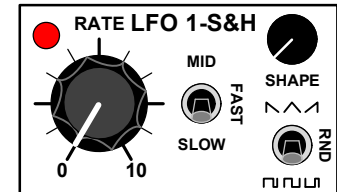

4.7.1.1. RATE

Adjust modulation speed. Depending on the position of the adjacent switch, you can work in the three excursions MID (top switch), FAST (middle switch) or SLOW (bottom switch). The speed varies from 0.1 Hz to 3 Hz (SLOW), from 3 Hz to 100 Hz (MID) or from 85 Hz to 2400 Hz (FAST).

It is advisable not to underestimate the modulations in audio band obtainable by placing the speed of the LFO circuit on FAST.

4.7.1.2. MID / FAST / SLOW

It is the switch that allows you to choose the three speed excursions previously indicated.

4.7.1.3. SHAPE

Regola the symmetry of the selected waveform with the three-position switch TRIANGLE / RND / PULSE (see below). Depending on the choice made with the switch, you can get the sawtooth variation - triangular - ramp (top position), or you can get the pulse variations 5% - square - pulse 95% (bottom switch).

The central position of the switch activates the Sample & Hold behavior in *stepped* mode.

4.7.1.4. TRIANGLE / RND / PULSE

Activates the desired behavior for the circuit. In the upper position, you can achieve sawtooth variations - symmetrical triangular - ascending ramp; in the central position (RND), the module functions as Stepped Sample And Hold; In the lower position, you can get the impulsive variations 1% - square to 50% - impulsive to 99%.

4.7.2. LFO 1 - S&H - Control Connections

Di seguito, la descrizione delle connessioni di controllo relative al modulo LFO 1 - S&H presenti sul pannello comandi dello strumento.

4.7.2.1. LFO 1 OUT

Below is a description of the control connections related to the LFO 1 - S&H module on the instrument control panel.

4.8. LFO 2

The module produces a cyclic control voltage adjustable between triangular and pulse with different SHAPE symmetry values. Also in this case, the signal LED makes the selected frequency visible.

4.8.1. LFO 2 - Controlli di pannello.

Below is a description of the LFO 2 commands on the front panel.

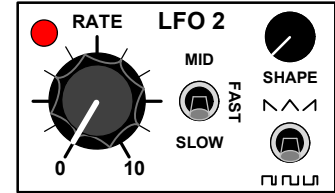

4.8.1.1. RATE

Adjust modulation speed; Depending on the position of the adjacent switch, you can work in the three excursions MID (top switch), FAST (middle switch) or SLOW (bottom switch). The speed varies from 0.1 Hz to 3 Hz (SLOW), from 3 Hz to 100 Hz (MID) or from 85 Hz to 2400 Hz (FAST).

It is advisable not to underestimate the modulations in audio band obtainable by placing the speed of the LFO circuit on FAST.

4.8.1.2. MID / SLOW / FAST

Is the switch that allows you to choose the three speed excursions previously indicated.

4.8.1.3. SHAPE

Adjust the symmetry of the selected waveform with the two-position switch TRIANGLE / PULSE (see below). Depending on the choice made with the switch, it is possible to obtain the sawtooth variation - triangular - ramp (top position), or it is possible to obtain the pulse variations 5% - square - pulse 95% (bottom switch).

4.8.1.4. TRIANGLE / PULSE

Activates the desired behavior for the circuit. In the upper position, you can achieve sawtooth variations - symmetrical triangular - ascending ramp; In the lower position, you can get the impulsive variations 1% - square to 50% - impulsive to 99%.

4.8.2. LFO 2 - Connessioni di controllo

Below is a description of the control connections related to LFO 2 on the command panel.

4.8.2.1. LFO 2 OUT

The port provides the modulation signal produced by the Low Frequency Oscillator - LFO 2.

5. FRONT PANEL CONNECTIONS

For the reader's convenience we bring together the descriptions of all the Input/Output connections present in the lower end of the front panel.

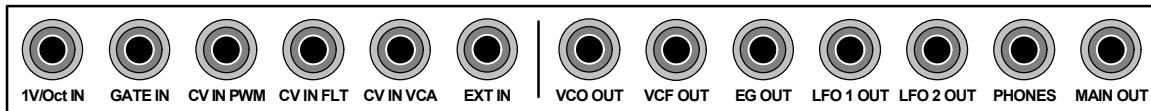

5.1. INPUTS

- **1v/Oct IN.** The connection is designed to receive 1V/Oct control voltages from keyboards, sequencers or other external control sources.
- **GATE IN.** The connection accepts the analog voltage 0/+5V necessary to trigger the Envelope Generator.
- **4.2.2.2. CV IN PWM.** The connection allows remote control of the PW symmetry of the SQR wave. The control input is not processed, so any attenuations on the signal must be provided from the outside.
- **CV IN FLT.** It receives the possible external control source applied to the Cutoff FREQUENCY. The control signal, unprocessed, must be attenuated at the source.
- **CV IN VCA.** Input for the control signal applied to the level of the Voltage Controlled Amplifier. A voltage of 0V closes the Amplifier; the maximum receivable voltage is +5V.

To control the VCA only with an external CV voltage, it is necessary not to activate the Gate (indifferently, analog or MIDI) and the Filter Envelope. With the VCA only under external voltage, it is recommended to limit the controls to only 1V/Oct management for the pitch of the oscillator, without using MIDI.

- **EXT IN.** It is possible to use a fourth signal coming from the outside and possibly connected to the EXT IN connection. In this case, it is necessary to provide externally for its volume adjustment.

Inside the instrument, on the back of the components board, there is a Jumper to select the sensitivity of the EXT IN connection.

- *No Jumper. The circuit accepts signals up to 10V p-p.*
- *Jumper in MID position. The circuit accepts signals up to 5V p-p.*
- *Jumper in HI position. The circuit accepts signals up to 1V p-p.*

The instrument comes with the Jumper in MID position.

5.2. OUTPUTS

- **VCO OUT.** The connection makes the audio signal produced by the oscillator available for any external use (or for modulations in audio band); the signal is not attenuated and comes out with a level equal to 10V p-p.
- **VCF OUT.** It is the audio output of the 18 dB VCF module. In this way, it is possible to use Grp A1 as a sophisticated processor for static or dynamic audio processing through modulation.
- **EG OUT.** The connection provides the control signal processed by the ADSR Envelope Generator. The voltage expressed is 0/+5V.
- **LFO 1 OUT.** The port provides the modulation signal produced by the Low Frequency Oscillator - LFO 1 (or, possibly, by the selected S&H behavior).
- **LFO 2 OUT.** The port provides the modulation signal produced by the Low Frequency Oscillator - LFO 2.
- **MAIN OUT.** It is the audio output of the synthesizer.
- **PHONES.** It is the output for listening to headphones, its volume is always regulated by the MAIN OUT command.

5. REAR PANEL CONNECTIONS

The back panel of the Grp A1 synthesizer includes connections related to:

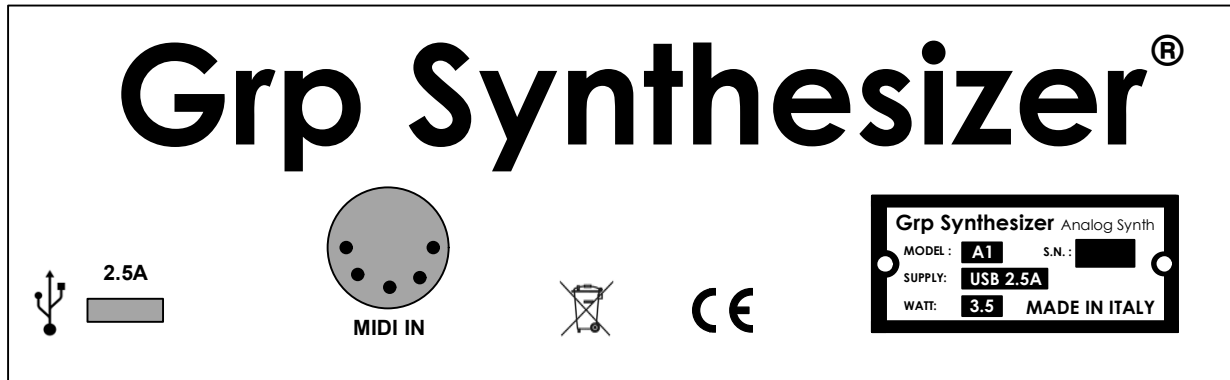

- **USB 2.5A.** Socket for powering the appliance (via power adapter or USB-compatible Type-C Power Bank) and/or for connection with the computer. In this case, the connection supports MIDI-over-USB and the instrument is seen by the computer as Grp Synthesizer to which MIDI data can be sent.

While Grp A1 Synthesizer has an effective absorption of 750 mA, some cheap USB power supplies may not guarantee - despite what is declared by the respective manufacturers - sufficiently solid energy to feed synthesizer on a regular basis. The same could happen with the USB ports of poorly energy-equipped laptops.

If necessary, it is recommended to use a powered USB hub, using it between the laptop and the Grp A1 Synthesizer.

Under no circumstances should Grp Synthesizer be held responsible for any malfunctions

- **MIDI IN.** Input connector for instrument control by MIDI peripherals or other MIDI synthesizers equipped.

Manual: Enrico Cosimi

Grp Synthesizer S.r.L.
Via Formello, 17
Monte Porzio Catone
00078 (RM) Italia

www.grpsynthesizer.it
info@grpsynthesizer.it