

RK-008 QUICK MANUAL firmware v2.23

Jul 15th 2024

USB AND REAR CONNECTIONS

Use the provided USB cable to power the RK-008 via it's USB-C Connector. You can make the RK-008 operate on battery power by fitting a Nokia4C or 5C style LiPo battery in the bottom compartment.

The battery will be charged if the RK-008 is powered via USB Power and the switch is set to the I position.

You can also use the USB-C Connector to connect with the RK-008 Settings page (<https://retrokits.com/rk008/settings>) You need to use a browser with webSerial capabilities like Google Chrome or MS Edge.

USB CABLE

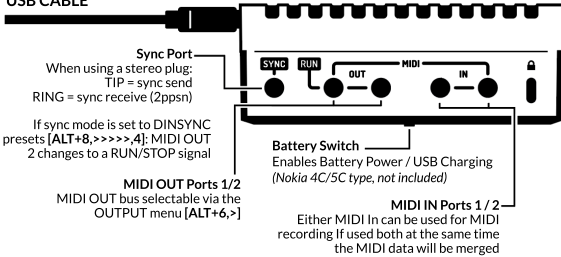

In DINSYNC presets, MIDI Port 2 can switch to a RUN/STOP gate signal for extra synchronization. You can e.g. use our RK-TRSPLIT cable to use both signals.

NOTE: RK-008 MIDI IN/MIDI OUT connectors are using the MIDI TRS-A Standard.

SONG/PART STRUCTURE AND DISPLAY

The RK-008 structure and display are shown below:

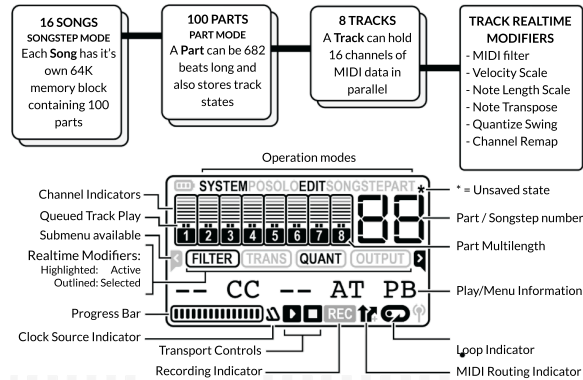

TEMPO INDICATOR

If you want the RK-008 to slave to a gate signal, set the clock source to AUTO (ALT+8,>>>5). When the RK-008 detects a gate clock, the metronome icon will light up. The RK-008 uses 2PPQN gate signals to slave to. This rate is compatible with volca's, pocket operators and is fairly common to generate with older drumcomputers via the accent track. The RK-008 uses upscaling to generate a MIDI clock from these low-rate pulses.

NOTE: Long-press the STOP button if you want to put the RK-008 to sleep. It will save battery consumption and also allows you to charge the RK-008 without operating it.

THE KEYPAD

The keypad is arranged in 4 elements: The digits, operation modes, tracks and transport controls. The ALT-key can access an alternate function. On the digit-keys these functions are marked with the orange color. There are a lot of other ALT-options available which you will appreciate while working with the RK-008.

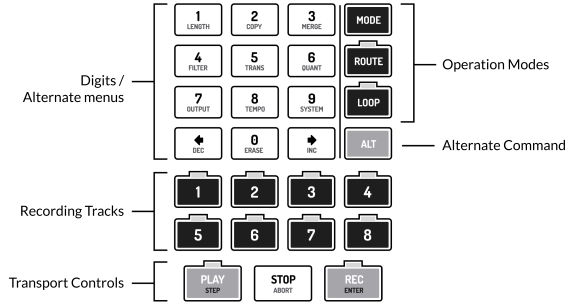

For Example:

- ALT+1** Sets the recording length of a Part.
- ALT+TRACK-x** Mutes/unmutes a track
- ALT+REC** Performs a quick save to memory
- ALT+ROUTE** Enters Performance Mode
- ALT+LOOP** Activates TrackTrig Mode
- ALT+< and ALT+>** Skips the playhead to a beat number

Once in an alternate function, generally the STOP or ALT-key exits/aborts the operation and the REC-key can be used as an ENTER/EXECUTE key.

HOW TO RECORD A MIDI PERFORMANCE [1]

Connect one of the provided TRS-A/DIN5Male cables to the RK-008 and your MIDI Keyboard/music device. If you have a TRS-A MIDI keyboard you can also just connect a Stereo minijack audio cable in between. For TRS-B devices, check our website for connection solutions.

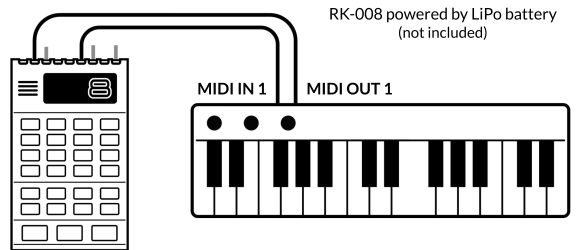

Above you can see a simple setup to add MIDI recording to a Synth. If you connect the RK-008 on a single MIDI device: Make sure 'MIDI Local control' on your device is set to 'off' to prevent note doubling. If this is not possible you can disable the direct MIDI output of the RK-008 by disabling the ROUTE option to prevent MIDI loops.

Note that if you do not use the RK-008 ROUTE output you will not be able to use the RK-008 MIDI switchboard capabilities like channel remapping and note transpose.



NOTE: These first two pages are a quickstart guide for playing with the RK-008. If you want to know more about the RK-008 menus **download the complete manual** from <https://retrokits.com/rk008/>

HOW TO RECORD A MIDI PERFORMANCE [2]

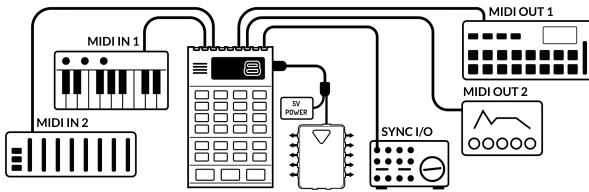

The schematic above shows a more extensive setup of RK-008. With 'ROUTE' and the OUTPUT-menu (ALT+7) you can configure the RK-008 as a MIDI switchboard, quickly changing output port / MIDI channel by just pressing a Track button. In this picture the RK006 Hosts the RK-008 and can also be selected as a separate output bus next to the existing outputs. You can select which MIDI goes to which channel and output port per Track.

The LED on top of the ROUTE pad indicates incoming MIDI messages. You can also see incoming MIDI messages on the RK-008 screen.

Select a Track to record to with one of the TRACK buttons (1-8). On the screen you will see the appropriate track outlined to indicate it is selected for recording. The recording Track LED will also blink to indicate your recording destination. Press REC to arm the RK-008 for recording.

Normally the RK-008 will use a 4-beat count-in until the recording starts. You can omit the count-in bars by pressing REC two times.

Pressing PLAY will start the recording. If you have no Part length set (ALT+1), the RK-008 will set the Part length to your recording. You can adjust the length later if you wish. If you want to shorten the recording the RK-008 will ask you which part of the recording you want to keep.

If you have made a recording, press REC again to stop and commit the recording to the Track. If you press STOP the recording will be deleted and you can try recording again.

If you are playing a Track which already contains data, pressing REC will overdub on that track. If you want to replace instead, mute the Track first with ALT+ [tracknr] or erase the Track with the Erase function (ALT+0)

Note that the PLAY button restarts a pattern from the beginning. If you have stopped playback and want to resume where you left off: Press ALT+PLAY to continue playing.

If you want to skip to a certain Beat on a long Part you can press ALT+> and enter a beat number to continue the playing.

So a single track can record MIDI data from any of the 16 available MIDI channels. How you are using the Tracks is up to you: You can use them for retakes and keep performances as spares or perhaps use as performance tools with mute/unmute and routing.

WORKING WITH PART RECORDINGS

After you recorded something you can edit the Part/Track structure with Digits 1,2 and 3. Below a quick rundown to get you started:

ALT+1 : LENGTH

Cut the length or increase the Part length. If you cut an existing recording, select which section you want to keep from the original: The Beginning or

the End, and press REC to cut. The result will be the length you have selected with the selected data from the original Part.

If you want to increase the Part length and you already have a recorded pattern you can choose to repeat-extend the existing MIDI data.

ALT+2 - COPY

Use the copy menu to replace Tracks or Parts, you can duplicate, explode (pull apart MIDI Data) or swap Tracks. When you have deselected all Tracks you can also make a copy of a complete Part.

ALT+3 - MERGE

You can use the MERGE menu to mix multiple Tracks together. You can also use it on a single Track to just mixdown real-time modifiers. If you have no Tracks selected you can merge a complete Part to another part -or- to itself. Merging a Part to itself will result in a double length-Part.

REALTIME MODIFIERS

If you have recorded something you can also let the RK-008 polish it up a bit. It has modifiers to change volume, transpose, quantize or alter the note length. All the performance modifiers are located in the 2nd row digits: 3, 4 and 5. They can be applied non-destructable. If you have applied any of these realtime modifiers on a Track, you can do a MIXDOWN (ALT+3) and they will be rendered to the recording. After this you can again add modifiers to the cleaned up Track.

ALT+4 - FILTER

Here you can play around with the velocity. For example if you want to play snappy basses it might help to modify notes by setting velocity transform to MAX, so you always play with full velocity. Digit 1-6 act as quick presets.

Digit 7,8 and 9 allow you to set velocity percentages of the original. Digit 8 will set velocity to 80% of the original and 7 or 9 will then respectively decrease or increase the velocity percentage.

On the next page (press >) in the menu you can also apply a MIDI filter on the selected track. You can block various MIDI channel messages in / out on the selected track. Use the filter/mixdown combo for permanent track cleanup.

ALT+5 - TRANSFORM

This menu adds transformation like basic transposing in an optional keyscale (ALT+1). Transposing a few notes can be nice to experiment with in finding harmonies. Pressing << before entering a number sets a negative transpose value.

If you enter 99 as a transpose value, the field will change into 'PRF' and the Track will be responding to note-transpose via the MIDI Remote Channel (if set) If you set the RK-008 into 'Performance Mode' (ALT+ROUTE) you can use notes to transpose a selection of Tracks set to the PRF value.

ALT+6 - QUANTIZE

Quantize can be used for various things. You can add swing to a Track, group notes into chords or change the note length. Same as in the Filter menu, Digit 1-6 act as quick presets, Digit 7,8 and 9 allow you to set percentages. You can use it in real-time to completely change a Track playback or just add little nuances



NOTE: These first two pages are a quick start for playing with the RK-008. If you want to know more about the RK-008 menus download the manual from <https://retrokits.com/rk008/>

INTO DETAILS

The former pages of this manual are used to quickly get you going with the RK-008. If you're wondering what else is under the hood: Now we will go a bit more in-depth on the RK-008.

STEPTIME RECORDING

Although the realTime full MIDI recording is what the RK-008 is all about, sometimes it is just handy to enter notes in a sequencer fashion, for example if you want to make a quick drumbeat or carefully timed controller data or program changes. For that we have made the stepTime recorder.

[ALT+MODE] Enters the stepTime recorder The stepTime recording mode is only available if you have previously set a Part length (**ALT+1**).

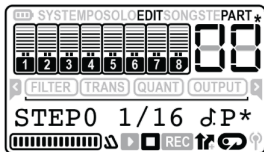

- ♪ Step has note data (. for long note)
- P Step has Program Change data
- * Step has CC, Pitch, etc. data

The RK-008 realTime playhead is now stepping over at fixed intervals. You can choose how long the intervals can be with the Digits 1-6. Tap a time division multiple times if you need to access triplets or duplets.

You can use the arrow keys to step through the Part (Tip, if you need to move fast through a longer Part: just choose a long timeStep division). The display will indicate the Step position and if there is a Note, Program change(P) or Other(*) MIDI data on the step. A note which exceeds the step length is marked with an extra dot (like in normal note notation).

Press **REC** to start the step recording. If a note (or a chord) is played the step will auto advance so you can quickly fill the Part with a sequence of notes. Your played note's duration will be taken into account on the step note length. If you only dial in Controller values the step will not advance so you can stack multiple CC values in one timeStep. You can navigate through steps with < and >.

You can clear a step by pressing '0'. If you only want to clear non-note data you can press **ALT+0**

StepTime events will sound via MIDI when playback is stopped so you can hear the step contents while navigating with buttons < and >

NOTE: As of firmware 2.23, pressing MODE again in the stepTime editor will enter Event Editor, see the extra addendum in this manual.

PROGRAM CHANGE ASSISTANT

Pressing **[7]** in stepTime will enter the MIDI Program Change assistant. Here you can add a Program Change /Bank Change on your track. Message details can be accessed by pressing the arrow right button.

Note that a MIDI Program Change message is set to a specific MIDI channel. The RK-008 can record on any MIDI channel so keep track on which device you want to send/receive the Program Change.

Normally the notes which arrive on the RK-008 MIDI input will select on which channel the Program Change is sent out. If you don't play notes the existing track data will set the channel. You can override the MIDI channel selection in the last page of the Program Change Editor.

Note: If the Track output is forced to a specific MIDI channel, setting it in the Program Change editor will have no effect.

You can play around with Program Changes by entering numbers or quickly send them out with **ALT+>** or **ALT+<**

If you enter **0+REC** for a Program Change the complete entry will be deleted from the Track. If you only want to clear a BankChange message, go to the MSB / LSB page and type a number over 127 (like 128 or 999)

In the Program Change editor, press REC to commit a Program Change to the Track or press STOP to exit the editor and leave the Track unaltered.

PER- TRACK ENDPOINTS

Pressing **9** on the stepTime editor inserts a Track end event

Example usage: Set the note division to 8th, Record one hihat note on step 0 and set the track end on Step 1: Now you have a repeating hihat track with only one note. Both a RK008 memory saver and convenient.

Another example; You can also only record multiple CC's or pitch changes on a track and make sort of a 'MIDI wavetable LFO': Combined with Track endpoints on different time intervals as the main Part length this way you can make polyrhythms on all aspects of MIDI with only a few events .

RK-008 BY THE BUTTONS

On the next pages we have summarized the RK-008 main buttons and the **ALT+ [digit]** menu combinations.

[MODE] Sets the RK-008 in Part or Songstep mode. In Part mode you can record your musical Parts, in Songstep mode you can chain these Parts together. You can also save mute states and track transposes on a Songstep to re-use a Part in the song structure. The REC key toggles between browsing through Songsteps or adding/changing Parts or Track mutes in a Songstep.

[ALT+MODE] Pressing ALT+MODE enters part stepTime mode, described in the extra pages of this manual.

[ROUTE] sends incoming MIDI messages through to the output of the RK-008. The selected track determines which processing is applied to the incoming MIDI message (in terms of modifiers, filters, transpose, MIDI channel and output port). Incoming MIDI messages are also indicated by a blink on the Route LED.

[ALT+ROUTE] Pressing ALT+ROUTE sets the RK-008 in Performance Mode. In this mode you can quickly mute/unmute tracks by pressing the Track buttons (while normally pressing Track keys will select for recording). If the RK-008 MIDI Remote Control Channel is set you can also invoke Track note transpose by a MIDI key. The transpose will be applied on all tracks which have '99' as their transpose value.

[LOOP] Depending on the RK-008 MODE state, LOOP will repeat the current Part or the current Songstep.

[ALT+LOOP] Pressing ALT+LOOP will set the RK-008 in TrackTrig mode. In this mode you can use the Track buttons to send out MIDI Notes. You can define which notes you want to send in the SYSTEM menu (**ALT+9**)

Note: You can also use the TrackTrig mode to send MIDI transpose when you are in Performance mode.

TRACK 1-8 / LED STATES

The 8 Track keys can be used to select the Record Track destination . If used in conjunction with **ALT** they will act as (un)mute keys. The LED above the Track button tell you about the contents:

OFF	Track contains no MIDI data
ON	Track contains MIDI data
DIMMED	Track contains MIDI data but is muted
BLINK ON/OFF	Track (empty) selected for recording
BLINK ON/DIMMED	Track (muted but containing MIDI data) is selected for recording

TRACK SOLO

Long-press a Track key to solo the Track. Add extra Tracks to solo just by pressing them. There are three ways to exit Solo:

1. If more Tracks are solo'd, press **ALT** to exit solo mode. The resulting Solo states will be set to Track mute/unmute states.
2. Reduce all solo Tracks back to one and short press this last one to exit and revert to your old mute/unmute state
3. Press **STOP** when in solo mode to revert the mix states.

If you have track solo active during Part change (also in Song mode) the **Track solo states will override the saved Track mute-states**. You can use this to your advantage in a performance.

Each Track can have its own real-time MIDI modifiers. You can apply the following transformations on note-data:

- Quantize (note on/length) & Swing
- Transpose
- Velocity

You can also set output Filter on the following MIDI Channel data:

- Notes
- Program Changes
- Controllers
- Aftertouch
- Pitchbend

The Merge/mixdown operation on Tracks will render/fix modifiers to Part memory. You can then again add new modifiers on the rendered Track(s).

You can also select each Track to Mute, force MIDI data to a single MIDI channel or route it to a specific Output port (OUT1, OUT2 or -if connected - the RK006). If any of these real-time modifiers are active it will light up in the RK-008 display.

Most keys are taken up by the digits, these are for selecting Parts but also have an alternate function which you can invoke with the orange ALT key. If you have a function activated the screen will show 'EDIT' active. Generally REC acts as an 'execute operation' and STOP as 'abort'.

[ALT] Pressing ALT+[grey numeric] gives you various RK-008 options.

[ALT+PLAY] Resume playback

[ALT+STOP] Send MIDI Note Panic

[ALT+MODE] Enter StepTime Recording

[ALT+LOOP] TrackButton Trigger (TrackTrig) mode

When Record is armed, there is a count-in when you press Play to start. If you want to omit count-in, press **REC** twice.

In 'calculator-CE-button-fashion': Would you like to return to main operation mode: Three presses max on the **STOP** button gets you home.

[ALT+DIGIT] MENU COMBINATIONS:

[1] PART LENGTH

Type the Part length with the numeric keys, Max 682 beats.

Note that beats are not applicable in free record mode (TEMPO menu). Changing an existing Part to a new length will give you three options in handling the data:

- Lengthen with a fill-repeat of the existing data (LOOPED) or just extend empty (BLANK).
- Shortening a Part you can choose to keep the begin or the end of the existing Part data.
- Selecting 'FLEX' will scale the existing Part MIDI into the new length.

[1 /2] SIGNATURE

Type timebase of the track (affects metronome click and loop detection)

[1 /3] PART SCALE

Select a scale preset to use on the part. To use this scale in the Transpose modifier, set 'SCALED' to 'YES' in the Transpose menu (**ALT+5**, >).

[1 /4] PART TEMPO

By enabling Part Tempo, the tempo you define in ALT+8 will apply only to this Part instead of using global Tempo. This allows for queued tempo changes in ad-lib Part playback or in a Song chain.

(NOTE: Part tempo needs a Part length to have effect)

[1 /5] PART NAME

Enter Part name here with digits 0-9 in Ye Olden E.161 phone style.

FIRMWARE 2.x and up

In fw 2.0 you are also able to set **multiple Track length** in the LENGTH menu. When entering this menu with **ALT+1**, press a Track button 1-8 to see or set the length of the Track. The display will now show which Track is active (e.g. 'T.1 008 BEATS')

Since the Track length can not exceed the Part length, Part length needs to be set prior to a Track length. You can type the Track length in 3 beat digits + 1 digit for the 16th note.

Example: 003 , 1 will set the track length to three beats plus one 16th.

You can also set Track endpoints on the **stepTime editor** with **button 9**.

TRACK PLAY MODES [fw2.14]

Pressing **INC** when in Track Length Selection allows you to change more properties which affect Track play and mute states

[1/T.x/1] QUEUED MUTE

Press digit 1 to 4 to select a queued mute time interval. This means a mute command can now be delayed so it can for example kick in exactly on the Part loop, even when you press mute much earlier. On Queued muted Tracks a Track play restart will also be initiated on unmuting. You can choose:

- 1 - **PART** Queues Mute state change on Part length
- 2 - **TRK** Queues Mute state change on Track length
- 3 - **BEAT** Queues Mute on the next quarter note (the beat)
- 4 - **1/16** Queues Mute on the next sixteenth note
- 0 - **OFF** Resets to normal mute unmute function.

[1/T.x/2] PLAY MODE

Selects if a Track will be played once when triggered or loop with the Part.

[2] COPY

The active Track will be used as a copy source. Select another Track to set the Track copy destination. Select a Part on the digit keys to copy selected Tracks to another Part. Deselect all Tracks to enter Part copy.

Note: To combine two Parts, use MERGE, not COPY (COPY overwrites).

[2 /3] SWAP

Select two tracks to swap their contents (structural organization). If all Tracks are deselected you can swap Parts with each other.

[2 /2] EXPAND

Enables note extraction on a Track with single-MIDI channel data and the extraction of separate MIDI Channels on a multi-channel Track.

[3] MERGE

Mixdown Track MIDI Modifiers (e.g. quantize, velocity, channel, ...) and/or merge multiple Tracks to one. After merging, modifiers are set to default.

If entered with a Track active, the Track will be used as the mixdown destination. Select other Tracks to include in mixdown by pressing the corresponding Track buttons and press REC to execute.

Deselect the active Track to enter Part Merge: Enter the two-digit Part number to merge to the current Part and press REC (DEC/INC changes Part number.)

Note: If you select the current Part as merge destination, effectively the Part will be merged to itself, doubled in length.

[4] FILTER

You can also use the FILTER modifier to change note velocity or clean out MIDI channel data from a Track.

[4 /1] FILTER Velocity

Numeric keys scale note velocity to:

[1]	20%	[2]	50%	[3]	90%
[4]	120%	[5]	150%	[6]	MAX
[7]	-10%	[8]	80%	[9]	+10%
[0]	ORG				

[4 /2] FILTER Events

Here you can filter MIDI channel event types. On fw 2.0 filtering works for **both incoming** and **outgoing** MIDI on a track so you can also use it to prevent unwanted MIDI data to be recorded as well.

You can use this feature to e.g. split controllers from note tracks or - in combination with Mixdown (**ALT+3**) - cleanup extra data from a Track: Just select the proper type to filter in realtime and mixdown the Track to actually remove the data. The Digit keys toggle filtering for:

[1] Notes	[2] Controllers	[3] Program Changes
[4] Aftertouch	[5] Pitchbend	
[0] No Filtering (def)		

[5] TRANSFORM

The transform menu allows you to change the notes on your played data, for example Transposing.

[5 /1] TRANPOSE VALUE

Enter numeric value to transpose the Track an xx amount of notes. Pressing < before entering the number enters negative transpose.

Pressing **ALT+<**, **ALT+>** the transpose value will be changed by 1.

If you enter **99** as transpose value, the Track will be set to Performance Transpose (**ALT+ROUTE**). Meaning the track will be transposed according to MIDI key input on the RK-008 MIDI Remote Control Channel.

[5 /2] TIMESHIFT

Enter Digits 1-6 for Timeshift values, double/triple taps displays more options. Digit 7 and 9 shift backward and forward. Press 8 to reset. Once a value is negative, Digits 1-6 will skip to negative values.

[5 /3] SCALE

Selecting YES will cause the transpose to be adhered to the selected scale in the Length menu (**ALT+1, >, >**).

[6] QUANTIZE

Quantization will allow you to adhere played notes to specific timebase in real-time.

[6 /1] QUANTIZE Timebase

Numeric keys set the quantize timebase. Select the Track you want to change the Quantize value and Press one of the Digits below to change the values. Press a Digit again to select alternatives like duplets or tuplets.

[1]	/64	[2]	/32	[3]	/16
[4]	/8	[5]	/4	[6]	/2
[7]	DEC	[8]	[G]	[9]	INC
[0]	OFF				

[6 /2] QUANTIZE Swing

Adds swing to the selected quantization:

[1]	52%	[2]	54%	[3]	56%
[4]	58%	[5]	60%	[6]	63%
[7]	DEC	[8]	[G]	[9]	INC
[0]	OFF				

ALT+> or **ALT+<** will increase and decrease note quantize/swing values, just as Digits 9 and 7.

GLOBAL QUANTIZE/SWING [fw2.14+]

When you don't select a Track you can change the Global Quantize / Swing values. These are a common value, applicable to every Track set to [G]. The display will show **QUANT [G]** or **SWING [G]** if you are changing the Global values. You can set the Track to a global Quantize or Swing by pressing Digit [8] on the appropriate menu.

[6 /3] QUANTIZE Note Length

Press once on the digits to set a fixed note length.

[1]	/64	[2]	/32	[3]	/16
[4]	/8	[5]	/4	[6]	/2
[7]	-10%	[8]	80%	[9]	+10%
[0]	OFF				

[8] Presets to 80% Key 7 and 9 are used to de-and increase the value.

Pressing the Digits multiple times give you access to more length quantize modes, for example:

- **Shortened or lengthened timebase** (indicated with - and +)

This is handy for making staccato's or preventing note overlaps (saving on polyphony) and legato's

- **Q-mode note length** (indicated with Q_)

Quantize note-off to the selected timebase grid instead of having a fixed Note length like in the other options (MMT8 Style).

[7 /1] OUTPUT MIDI Channel

Each track can contain data on all sixteen MIDI channels. Type channel 1-16 on the digits to force a single MIDI channel. (00 reverts to omni/original)

[7 /2] OUTPUT Output Port

Select track hardware output:

[1]	OUT1	[2]	OUT2	[3]	RK006
[4]		[5]		[6]	
[7]		[8]		[9]	
[0]	ALL				

(if DINSync is selected in TEMPO [8/6], DIN appears on the screen).

[8] TEMPO

An intricate menu related to time handling on the RK-008. By default the settings will suffice for MIDI recording but there are a lot of possibilities here to change the RK-008 tempo handling and play along with other MIDI devices (and more).

[8 /1] TEMPO - BPM Value

Enter value to set the tempo (if tempo is set to internal at menu 8/4).

Use **ALT+<** , **ALT+>** to finetune decimal value if needed.

If you want to quickly set a Part Tempo (ALT+1, >, >) you can also type tempo '0' (+REC) and the Part Tempo / Global tempo will be toggled. Part Tempo will be indicated by an extra P on screen.

Note: You can press **ALT+8** multiple times to use it as a tap-tempo

[8 /2] TEMPO - CLICK (metronome)

Use the numeric pad to change metronome options. The keypad columns change audible timebase on the click signal:

[1] REC+PLAY	Send click to speaker at all times.
[2] REC	Send click to speaker while recording only
[3] PLAY	Send click to speaker while recording only
[0] OFF	No metronome output

[8 /3] TEMPO - CLOCK SOURCE [INT]

Use the numeric pad to change MIDI clock source:

[1] IN1	MIDI / IN1	[6] SNCx	SYNC -in modes (multi- tap)
[2] IN2	MIDI / IN2	[9] STEP	Steps the RK008 1/16th note time on a clock pulse
[3] RK006	RK006 via USB	[0] INT	RK-008 internal clock (default)
[4] OFF	Free record (no BPM)		
[5] AUTO	Auto detect clock source (Also gate-in)		

Tapping [6] multiple times changes sync-in clock rate values.

[8 /4] TEMPO - TX CLOCK [ON]

Send MIDI clock to outputs

[1]	Disabled
[2]	Enabled (default)
[0]	Enabled (default)

[8 /5] TEMPO - STARTSTOP [RXTX]

Changes handling of MIDI Transport (start/stop/continue):

[1] RX	Receive only
[2] TX	Send only
[3] NONE	No sending/receiving
[0] RXTX	Send and receive (def.)

[8 /6] TEMPO - SYNC OUT [VOLCA]

Use the numeric pad to change the Sync Out Jack clicktrack timebase.

Press multiple times to select timebase alternatives:

[1] BAR/	[2] VOLCA	[3] PPQN
[4] DINxx	[5]	[6]
[7]	[8]	[9]
	[0] DEFAULT (=VOLCA)	

IMPORTANT: Sync out **DINxx** presets changes MIDI Out port 2 to a **digital RUN/STOP signal!** If active, this will be indicated on the OUTPUT menu (7/2) and MIDI will not be available on this port.

[9] SYSTEM

In the system menu you can save songs or templates and do advanced MIDI settings for the RK-008.

[9 /1] SYSTEM - SONG

The System menu has sub-levels. Press REC to enter the SONG sub-level in order to Save/Load Songs or a Template. You can press **ALT** to go back up one level).

• SAVE SONG

There are 16x 64K of song memory blocks. Saving a song also means choosing the active song memory to work in. A Song consists of the 100 parts you can play through in a performance plus the songstep sequence. (A shortcut for quickly saving the active Song: ALT+REC)

• LOAD SONG

Loads and sets an active song memory.

• SAVE TEMPLATE

A Template is a default Part routing setup. Initially every Track in a Part outputs to All MIDI outputs / all MIDI Channels. If you have a specific setup (e.g. Track 1 =MIDI channel 1 and Track 5-10 to MIDI channel 10, separate quantize, transpose, ...) - Then you can make the RK-008 start with this setup on an empty Part. This can make MIDI routing by Track selection easy to use.

• CLEAR TEMPLATE

Removes all predefined output and filter associations from Tracks and reverts to the default 16 MIDI Channels per track and port output mode.

Note: Pressing **ALT+REC** is a quick key combo for saving a Song.

Save and Load operations can affect playback: Avoid the urge to save your current performance while in a live situation :-)

[9 /2] SYSTEM - MIDI SETUP

• MAP WHEEL [OFF]

Allows you to remap the Modulation wheel into a custom MIDI controller. The maximum controller number is #119.

- Enter the Controller number with the numeric keys for remapping. Input value #0 to disable the remap.

- Input value #1 to change the Modulation wheel into Aftertouch message (Channel Pressure).

• CLICK-OUT [SPK]

Selects the Metronome output (ALT+8/2)

[1] SPK - outputs to the RK008 speaker (def)

[2] MIDI outputs to MIDI channel 10)

[3] Output to both Speaker and MIDI

You can mute the click signal in the Tempo menu (ALT+8/2)

• REMOTE CHANNEL [OFF]

The Remote Control Channel allows you to control the RK-008 from a MIDI Device. It allows MIDI Note Transpose in the Performance Menu as well as Play/Stop, Mutes, Recording and Part Changes via MIDI (available in Performance Mode with: ALT+ROUTE).

Select the channel with the numeric keys or enter channel 00 to disable RK-008 MIDI Remote Control.

Remember that **if the Remote Channel is set**, normal MIDI behavior is disabled for that MIDI channel.

• BLE MODE [OFF]

Enables the RK008 BLE Radio. Use 1 to set it to *peripheral mode* or 2 for *party mode* where the RK008 searches for BLE pairing at startup.

• BLE DIRECTION [IN+OUT]

Enables the BLE MIDI direction, 1: into the RK008, 2: out from the RK008, 0:bidirectional BLE (default)

NOTE: To save bandwidth the RK008 does not send clock over BLE

[9 /3] TRACKTRIG MAPPING

Here you can define which notes are available on the 8 Track buttons when the RK-008 is set to TrackTrig mode. You can define the Notes, velocity and MIDI channel per Track button.

[9 /4] SYSTEM - RK002 REMOTE

An exciting feature if you also have our RK002 Smart MIDI cable:
Connect the RK002 in loopback to the RK008 and press REC to read the RK002 Control Parameter list (these parameters vary per firmware). The RK008 will make a copy of these parameters into the RK008 menu for easy control without the need to connect the RK002 to our DUY portal
Once the parameter list has been read you can disconnect the RK002 MIDI out and control the RK002 parameters via the RK008.

Check <https://duv.retrokits.com> for a whole lot of fun RK002 MIDI processors to play/develop with like arpeggiators, delays, euclids, etc.

[9 /5] SYSTEM - INFO + TWEAKS

A menu for flavoured tweaks and device information.

- **VERSION** - Shows the installed RK008 firmware
- **CLICK-OUT**
Press digits to switch the MIDI click signal destination (Speaker, MIDI or Both). Press 0 for default (speaker) mode
- **QUEUEMODE**
Changes the Part queue mode, normally on Part change while playing the RK008 will queue up the next Part on the nearest BAR (digit 0). If you want to play the whole Part completely, press digit 1 (PART), a dot will appear in the on-screen LOOP icon to show this queue mode.
- **STEPMODE**
Change Step start count in stepTime with digit 1 or 0 (def=0).
- **BUILD** - Internal firmware code

[0] ERASE

When a Track is active you can erase one or more Tracks, just press the according Track buttons to erase and press REC.

Deselecting all Tracks will allow you to delete a complete Part and set the length back to zero.

[0 /1] THIN

The THIN function will try to reduce recorded MIDI data for memory optimisation, for example intensive Pitch or CC data. It can also be used to detect and erase double notes.

If Tracks are selected, thinning will only affect the selected Tracks. Without Track selection the whole Part will be thinned.

Thinning tries to optimize as much as possible without audible artifacts but stepping can occur. If you want to make creative use of stepping CC/Pitch data you can choose a quantization factor with the Digit buttons similar to the Quantize menu (ALT+6).

[0 /2] ERASE MIDICHANNEL

Use the digits to select the MIDI channel you want to erase from the track and press REC - or check the tip below:

ERASE TIP: In the erase menu you can choose to delete / thin a specific note, CC message / channel from the Track by pressing the note or wiggle a controller on a device connected to the RK-008 MIDI IN. The message will appear on the display and can be deleted by pressing REC.

SONG MODE

Press the MODE button on the RK008 to enter Song Mode. Now you can create a predefined sequence of Parts. While in Song Mode, press REC to edit the Part sequence. Just enter the 2-digit number of the Part you want to insert in the Songstep and navigate with the DEC/INC buttons.

While REC is active:

Brackets around the editable Songstep will blink. You can set per-Track mute states and individual Transpose value in a Songstep, making the most

of the Parts you have. Press LOOP to loop a section of the Song. ALT+0 erases a Songstep. ALT+/INC inserts a Songstep

THE RK-008 ONLINE MANAGER

<https://retrokits.com/rk008/settings>

The Manager page allows you to backup song data from the RK-008 as well as exchange recorded RK-008 MIDI data via SMF (Standard MIDI files). SMF files can be imported to or generated from a DAW
If a new RK-008 firmware update is available it will show an upgrade box in the page.

The latest available firmware version is shown in the Browser title bar.

RK008
MULTITRACK MIDI RECORDER

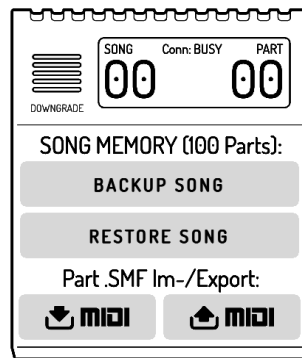

To use the online manager:

- Connect the RK008 to the computer via the provided USB-A to USB-C cable.
- Google Chrome / Windows Edge use **webSerial** (NOT webMIDI) - use one of these browsers.
- If the RK008 is not recognised as a serial port, install the driver via the links given.
- Allow webSerial access for the RK008 manager page

Select the RK008 Song/Part combo which you want to work with on the RK008 itself. The display on the settings manager will indicate the current active Song/Part.

Click on BACKUP SONG if you want to make a RK008 memory dump from the current Song (100 Parts).

Click on RESTORE SONG and you will be able to select a RK008 backup to restore to the RK008.

Click on the left lower MIDI button to render and export current Part contents to a standard .mid file. You can import these .mid files into a DAW like Protools / Logic / Cubase / Reason / Bitwig /... and work with your recorded RK008 MIDI Data.

To import .mid files to the RK008 press the right lower MIDI button and select the .mid file you want to import.

ADDENUM Fw2.28 : EVENT EDITOR (nerd mode)

In the stepTime editor you can go through the realtime recording in fixed intervals. This way you can combine stepTime editing with the realtime recording.

In RK008 firmware 2.27 we added an Event Editor which enables you to dive deeper into the recorded MIDI data.

HOW TO USE

Once in stepTime edit mode (**ALT+MODE**), navigate to the needed position with the **DEC** and **INC** buttons.

Press **MODE** to enter the Event Editor. The RK008 will try and show the nearest MIDI event to the time you selected and display detailed information about the MIDI event.

This is the **first level** of the event editor. Browse through the events with the **DEC** and **INC** buttons. Use **ALT+DEC** and **ALT+INC** to shift the note start-time without the need to go into detailed editing.

For simplicity, assume we have MIDI Note events on the recording. In first-level editing, the screen can show something like this:

```
000/60 NT A2
```

Meaning:

```
Start Time: 000/60
Type:      NT (=note)
Note:     A2
```

MORE DETAIL

Press **REC** to enter the **second level** you will see parameters belonging to the MIDI event in a separate screen. Continuing on a Note Event, these will be the screens involved moving through the screens with the **INC** button:

```
NOTENUM A2
VELOCITY 028
NOTELEN 000/60
MIDICHN 01
```

You can select and edit these parameters with the digits by pressing **REC** or use **ALT+INC** / **ALT+DEC** to just nudge the parameters up/down.

Entering this 2nd level and moving to the left with the **DEC** button you will see these entries:

```
ERASE EVENT
[NEW EVENT]
TIME (event timestamp)
```

Pressing **REC** in one of these entries will erase the event or allow you to make a new MIDI Event at the selected timestamp. When selecting **NEW EVENT** you will be presented with MIDI event types you can navigate with the **INC/DEC** keys. After selecting the desired event with the **REC** button you can edit event details similar to the Note event shown above. Event types to select are:

```
NOTE EVENT
CONTROL CHANGE
PROGRAM CHANGE
PITCHBEND
CHANNEL AFTERTOUCH
POLY AFTERTOUCH
```

Most events in MIDI have a limited range from 0-127. An exception to this is the Pitchbend event which has a much wider range and can be negative as well. To enter a negative value for pitchbend, press **REC** to activate input mode and press **DEC** to enter the negative range.

On all levels: press **ALT** to exit and move back to the main input mode.

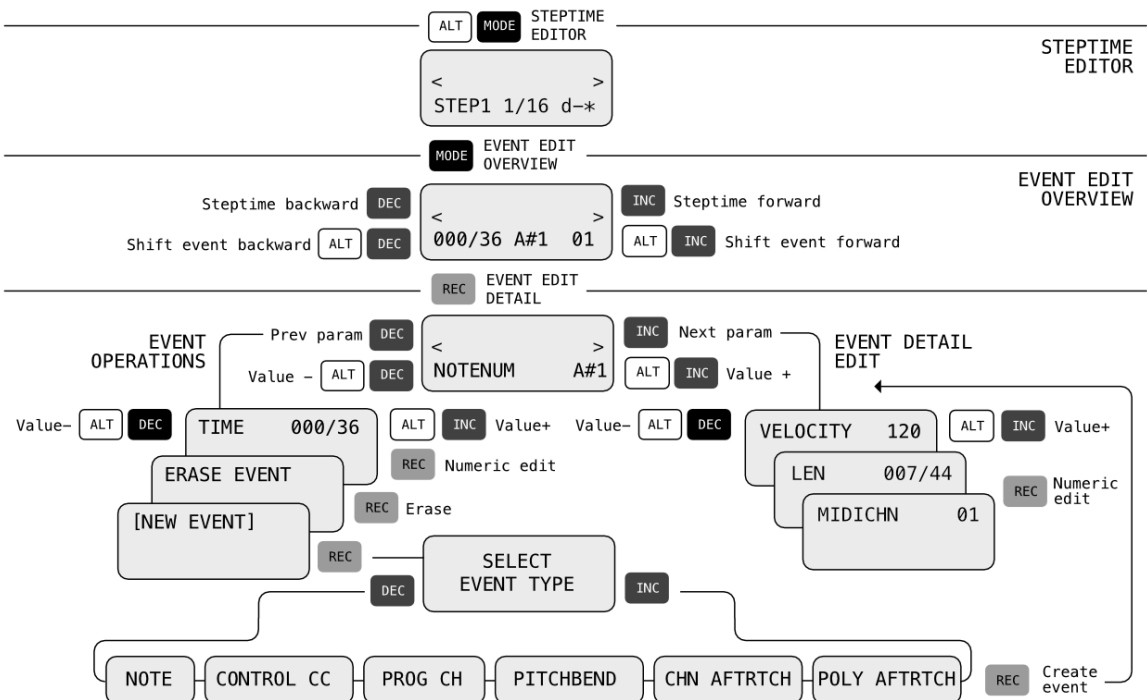

Function		Transmitted	Recognized	Remarks
Basic Channel	Default Changed	1-16 1-16	1-16 1-16	
Mode	Default Messages	0	0	
Note Number	True Voice	0 0-127	0 0-127	10-17 *1 18-25 *1 60 76,77
**REMOTE MODE	Select Track Mute Track Transpose basekey Midiclick notes			
Velocity	Note on Note off	0 X	0 X	
After touch	Key+chan	0	0	
Pitch Bend		0	0	
Control Change	0-127	0	0	105 *1 115 *1 117 *1 103 *1 102 *1
**REMOTE MODE	Stop Play Record Play prev Part Play next Part			
Program Change	0-127	0	0	126 = Part Prev 127 = Part Next 0-99
**REMOTE MODE	Part change			
System Exclusive		0	0	
Common		0	0	
System Real Time		0	0	
Aux Message		0	0	
Notes: *1 REMOTE MODE Messages respond on toggle button state				

O : YES X : NO