

Nakamichi 610

Control Preampfier Operating Instructions

CONTENTS:

Control Functions	1,2
Connections	
Microphone, Record Player, Tuner ..	3
Tape Deck, Power Amplifier	4
Remote Control Unit	5
Precautions	6
Using the 610 as a Preamplifier	7,8,9
Using the 610 as a Performance Checker	10,11,12
Using the 610 as a Mixer	13,14,15,16
Block & Level Diagrams	17
Troubleshooting Chart, Service Information	18
Performance Data	19
Specifications, Accessories	20

We thank and congratulate you for
your purchase of this Nakamichi 610
Control Preamplifier.

It is our belief that the 610 is an exceptional
product in terms of both performance and
features. Other manufacturers will no doubt
imitate the 610's features, but Nakamichi's
advanced engineering is your assurance that
the 610 will stand alone in the area of performance
for many years to come.

Since the Nakamichi 610 offers a level of
flexibility never before available on consumer
electronic products, its incorporation into your
music system and its operation will be quite
unlike anything else you are likely to have used before.
We ask, therefore, that you carefully read this
instruction booklet in its entirety before
attempting to use your 610.

If you should have any questions not answered in
this manual, please consult your nearest Nakamichi
dealer.

NAKAMICHI RESEARCH INC.

Control Functions

OUTPUT SELECTOR

Channels the Monitor Output of the 610 through one of three Level Matching Controls (see below). Also, when used with the optional RM-610 Remote Control Unit, selects one of three loudspeaker pairs or one of three stereo power amplifiers (see page 5).

FUNCTION SELECTOR

Selects Line A stereo inputs, Line B stereo inputs, Mixing mode or Test Tone mode.

TEST TONE SELECTOR

Selects one of seven sine wave frequencies or pink noise (see page 10).

TEST TONE LEVEL CONTROL

PHASE INVERTER SWITCHES

Reverses the phase (180 degrees) of the respective mixer inputs. Operates in the Mixing mode only (see page 13).

MASTER LEVEL CONTROL

Serves as the mixer output level control and master record level control.

STEREO HEADPHONE JACK

PRESET MARKER

Serves as a reminder when using the Master Level Control for fade-in/fade-out effects.

LINE A LEVEL CONTROLS

Provides independent left and right level setting for the selected Line A stereo input.

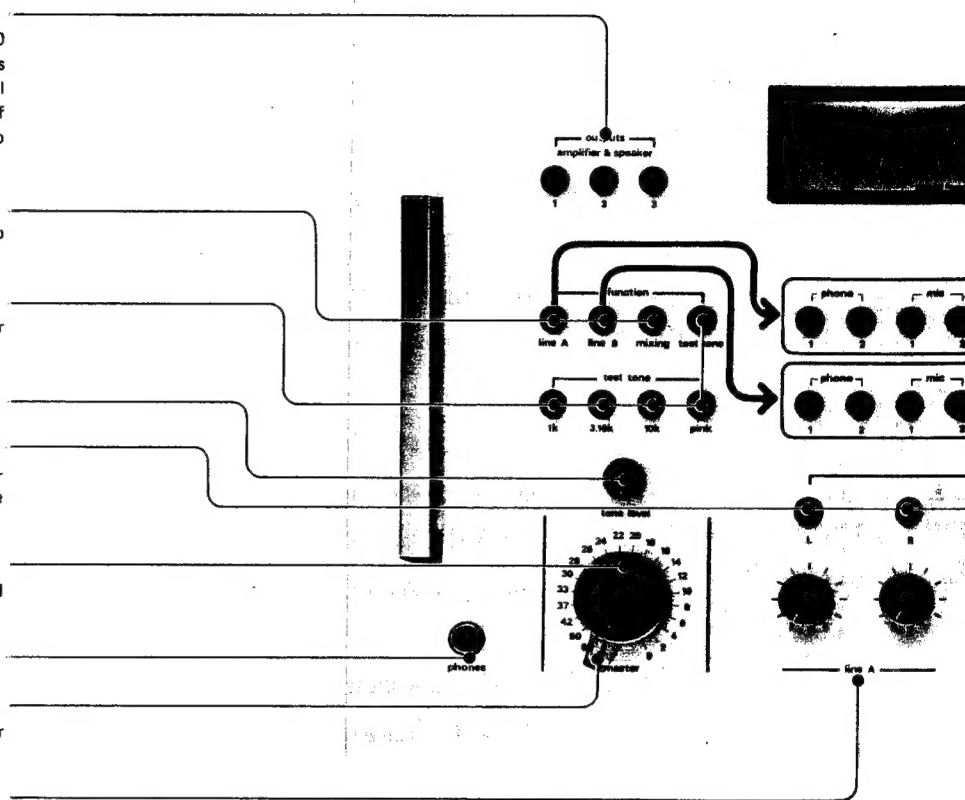

LEVEL MATCHING CONTROLS

Allows the pre-setting of levels in order to match the efficiencies of three different loudspeaker pairs (or the gains of three different stereo power amplifiers) connected to the optional RM-610 Remote Control Unit (see page 5).

REMOTE CONTROL SOCKET

The optional RM-610 Remote Control Unit is connected to this socket.

AC OUTLETS (SWITCHED)

AC POWER CORD

LINE VOLTAGE SELECTOR

MONITOR OUTPUT JACKS

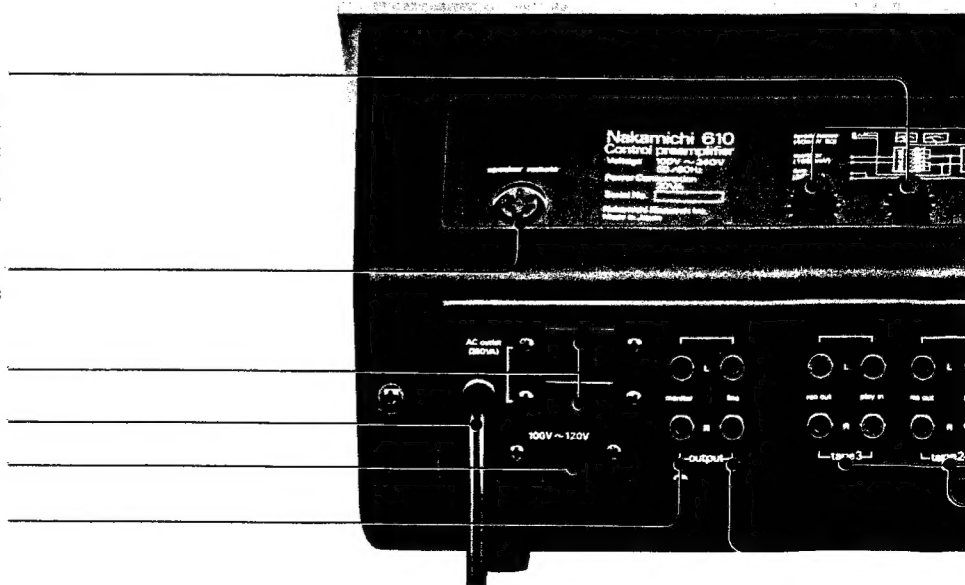

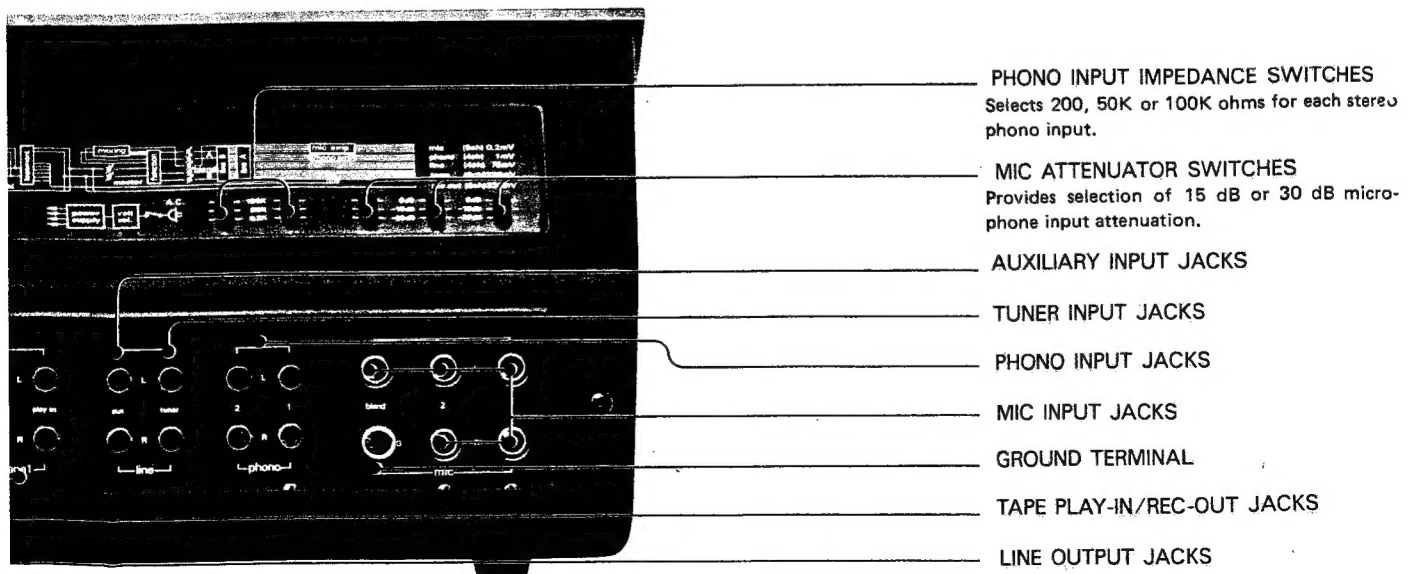
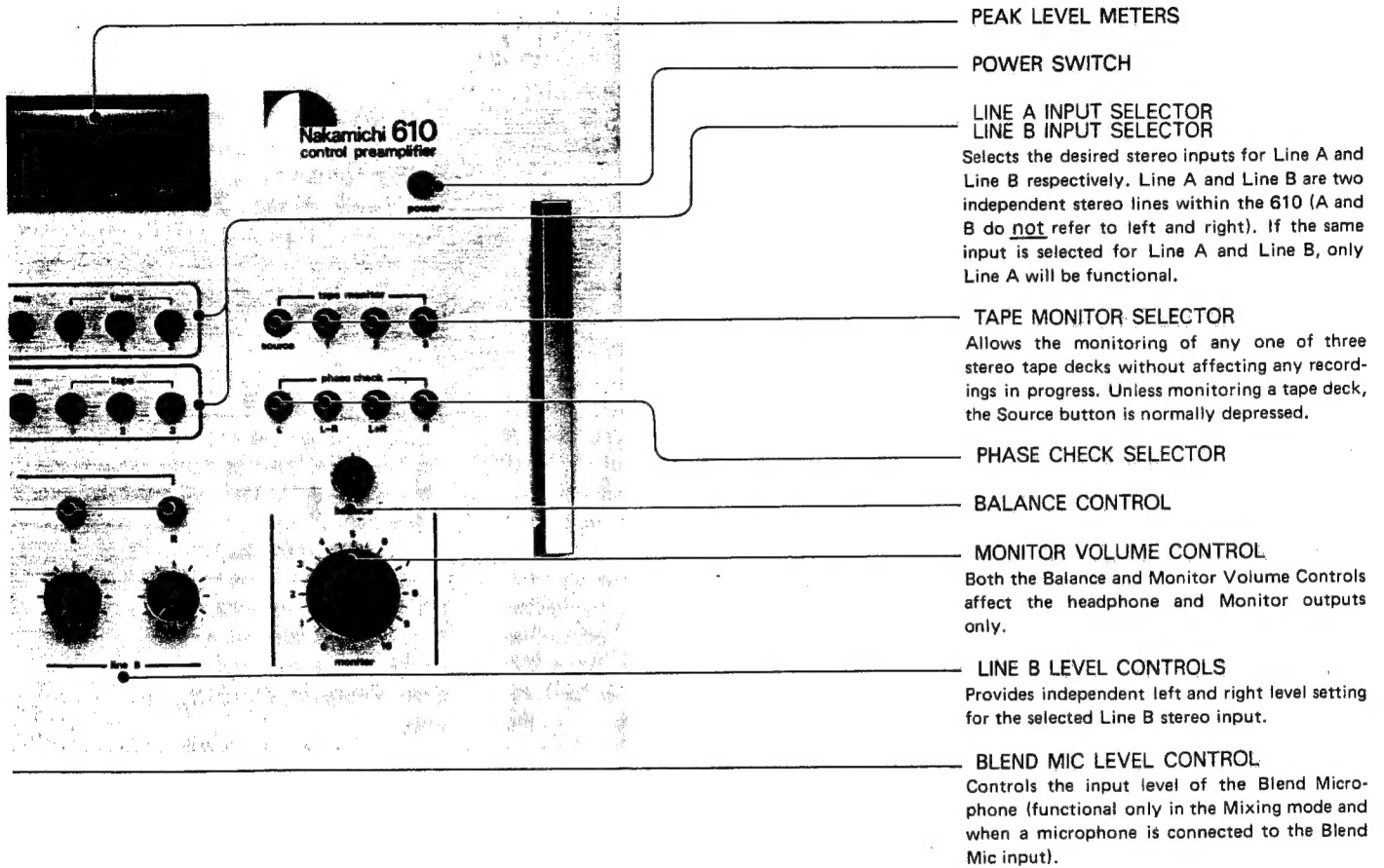

Connections (1)

Microphone/Record Player/Tuner

1. Microphones

The 610 accepts up to 5 microphones: 2 left, 2 right and 1 Blend (center channel). The microphones should be within the impedance range of 200 to 1,000 ohms and the sensitivity range of $-74 \text{ dB} \pm 10 \text{ dB}$ ($0 \text{ dB} = 1 \mu\text{bar/M}$).

The microphone cables should terminate in standard 1/4-inch phone plugs (2-conductor).

When using high output electret or condenser microphones with high sound pressure level sources, it may be necessary to utilize the mic input attenuators to avoid clipping the mic preamps. Either 15 dB or 30 dB attenuation may be selected. Mic attenuators 1 and 2 are stereo attenuators in that both left and right channels are switched simultaneously. The Blend Mic Attenuator affects only that microphone input.

The Mic Attenuator for any microphone

input not in use should be left in the 30 dB position to guard against unwanted noise.

2. Record Players

Connect the output cables of the turntable/tonearm to the 610's phono inputs observing the left/right indications.

Connect the ground wire from the turntable to the Ground Terminal.

Select the appropriate input impedance with the Phono Input Impedance Switch as recommended by the manufacturer of the phono cartridge (most magnetic cartridges require a 50K ohm input impedance).

Certain low-impedance/low-output moving coil cartridges may be connected directly to the 610's phono inputs (the impedance selector should be set at 200 ohms). Others will require a "pre-pre-amplifier" or transformer (such as the

Nakamichi MCB-100 Pickup Booster) between the cartridge and the 610's phono inputs. For the latter situation the 50K ohm input impedance is recommended. The input impedance switch for any unused phono input should be left in the 200 ohm position to guard against unwanted noise.

3. Tuner

Connect the output of the tuner to the Tuner Input of the 610 using a standard double phono plug-to-phono plug audio connecting cable. Observe the left/right indications.

If the tuner provides output level controls, these may have to be adjusted so that the signal from the tuner is not "too loud" or "too soft" in comparison to the record player or other source for any given setting of the 610's volume controls.

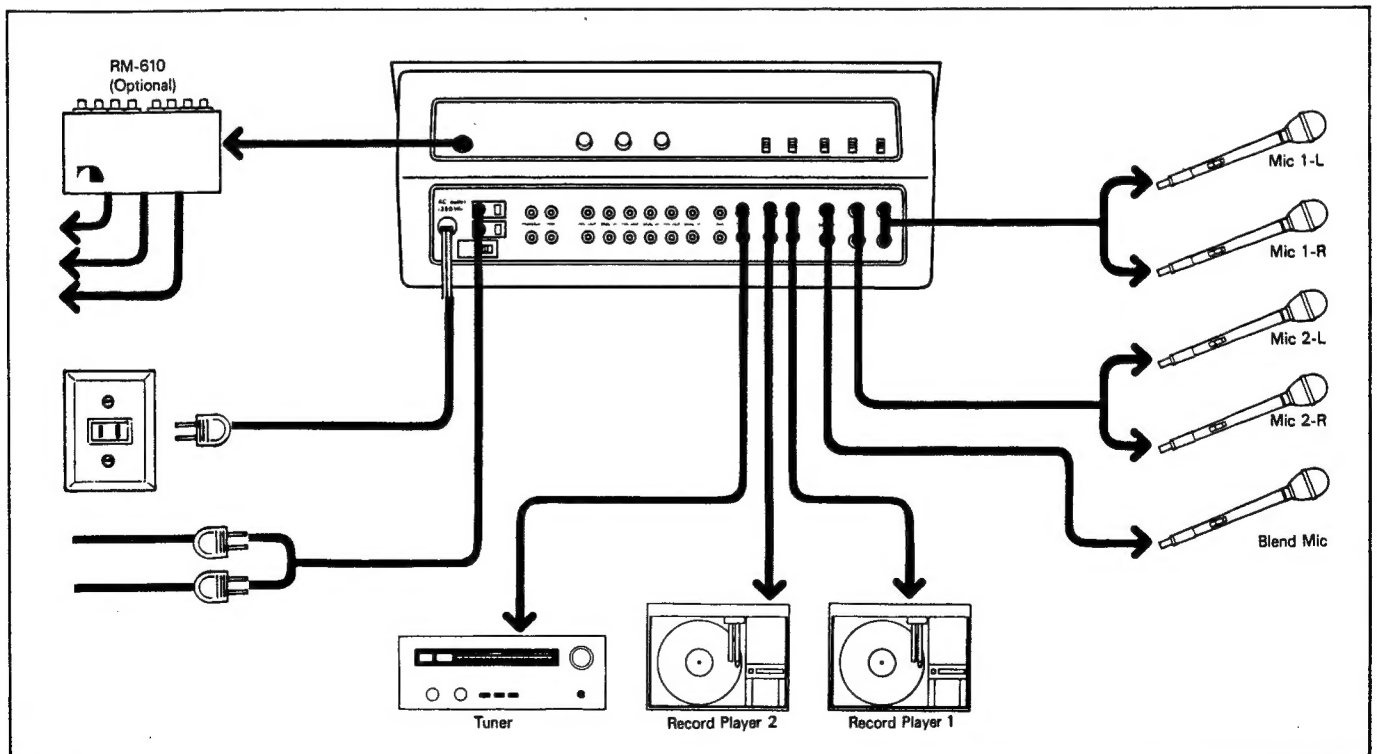

Connections (2)

Tape Deck/Power Amplifier

1. Tape Decks

The 610 provides three complete tape in/out circuits with full monitoring capability. The line inputs of each deck should be connected to the respective Rec Out jacks of the 610 using a standard phono plug-to-phono plug stereo connecting cable (consult your dealer if your tape deck requires special connectors). The outputs of each tape deck should be connected to the respective Play In jacks of the 610 in a similar manner. Observe left/right indications throughout. A fourth tape deck may be connected to the 610 by utilizing the AUX input and Line output as shown in the illustration.

The output of the tape deck should be connected to the Aux input of the 610, and the Line output of the 610 should be connected to the deck's line inputs. A tape deck connected to the 610 in this manner cannot be monitored during record.

2. Power Amplifier

Connect the Monitor Output of the 610 to the power amplifier input using a standard phono plug-to-phono plug stereo connecting cable. Observe left/right indications.

The Line output of the 610 may be used for this purpose, but note that the Line

output is not affected by the Monitor Volume Control, Balance Control nor the Phase Check Selector.

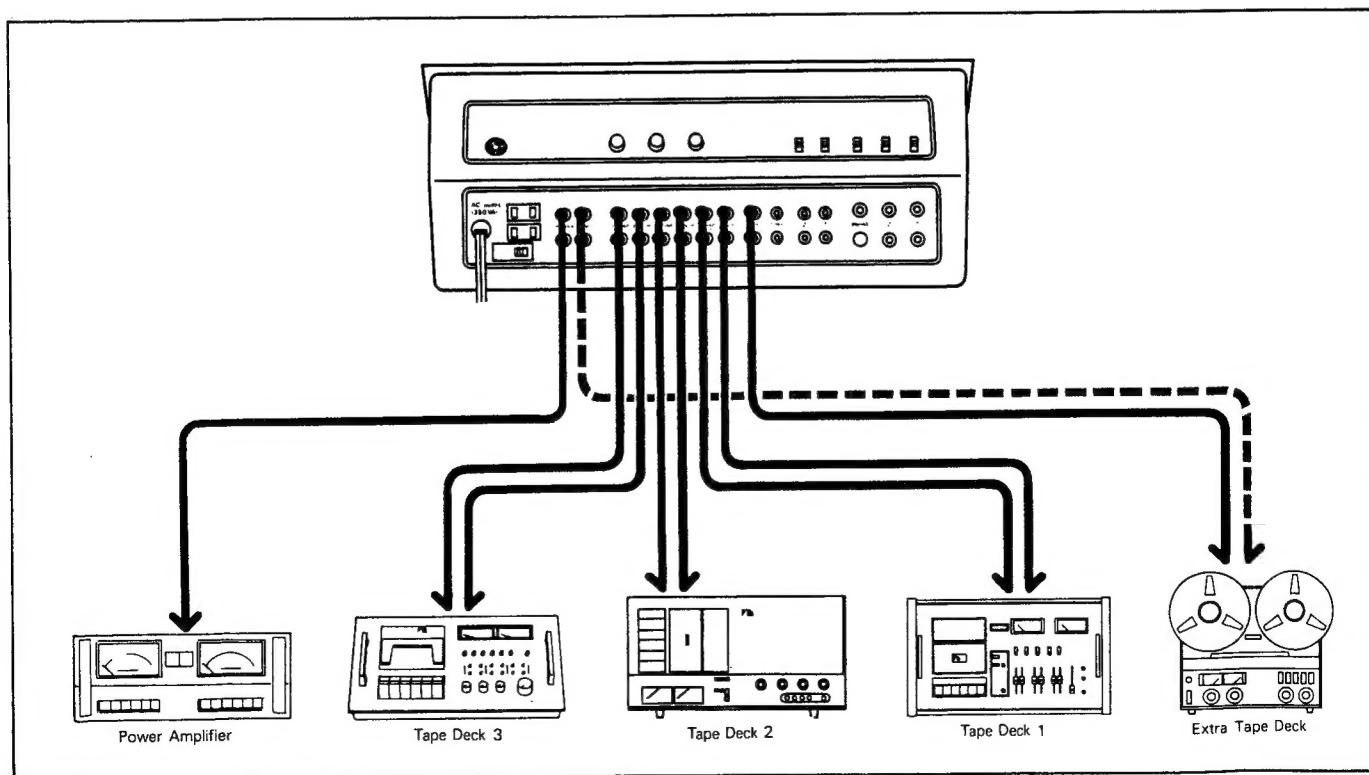

Connections (3)

Remote Control Unit
(optional)

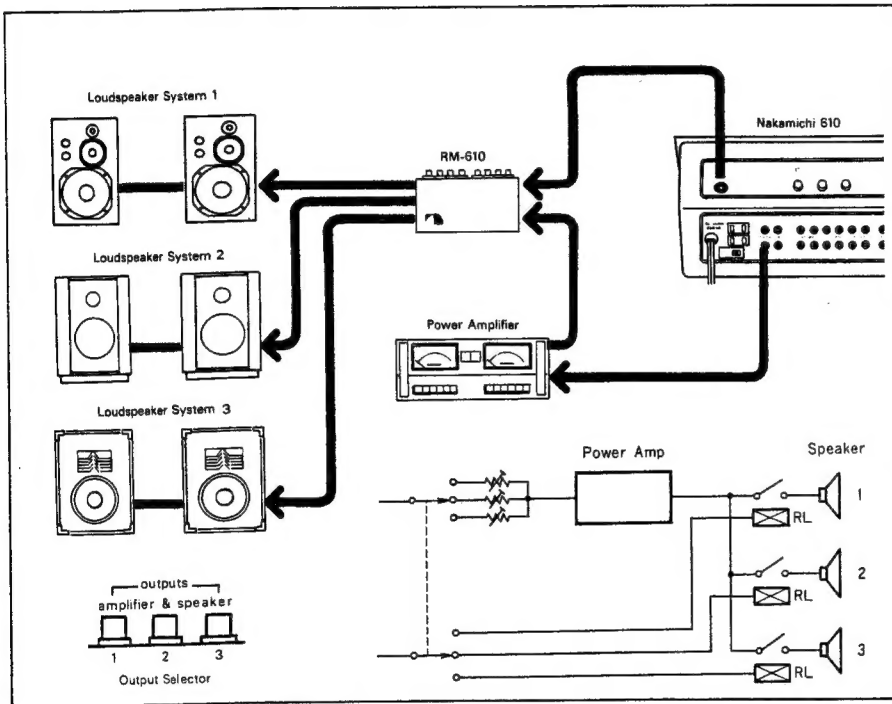

1. Loudspeaker Switching

Connect the 610 to the RM-610 Remote Control Unit with the connecting cable provided with the latter. Connect the Monitor output of the 610 to the power amplifier as usual. Instead of connecting the power amplifier outputs to the loudspeakers, however, connect the power amp outputs to the "Common" terminals of the RM-610 using speaker wire. Observe plus and minus polarities. Connect up to three loudspeaker pairs to the terminals on the RM-610 marked 1, 2 and 3.

When an Output Selector button on the 610 is depressed, the RM-610 will switch the output of the power amplifier to the selected loudspeaker system. If the listening levels of the loudspeaker systems are to be matched for A-B comparison purposes, the Level Matching Controls on the rear of the 610 can be used to compensate for the different efficiencies of the loudspeaker systems.

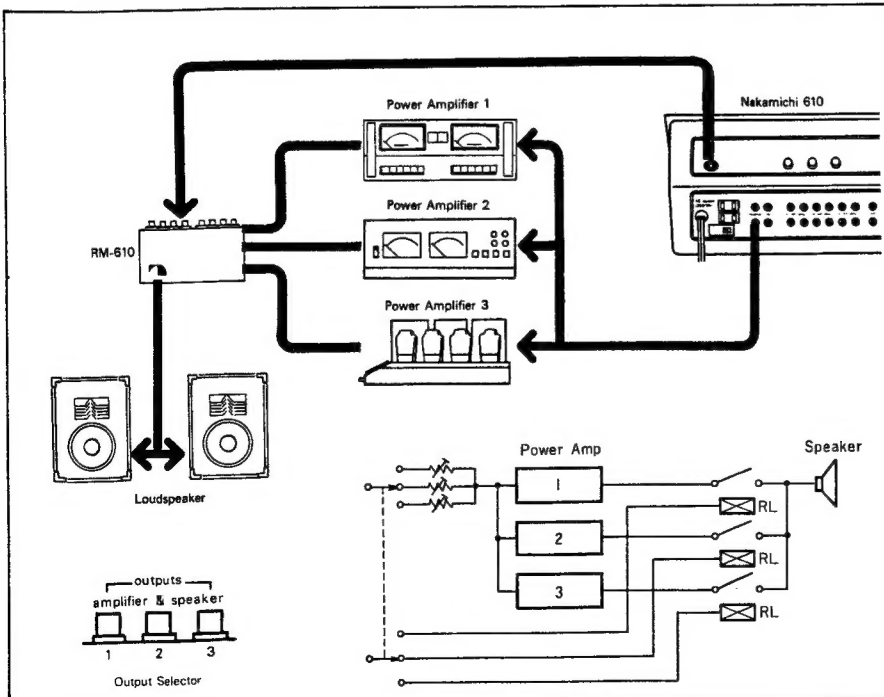
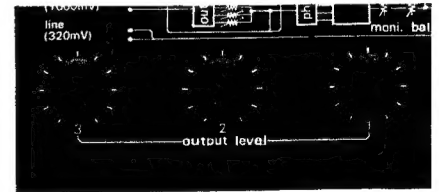

2. Power Amplifier Switching

Connect the Remote Control Unit to the 610 with the connecting cable as in the above case. The Monitor output of the 610 must be connected to the inputs of all three power amplifiers (or both power amplifiers if only two are to be used). Your dealer can help you find or fabricate the special connecting cable required for this purpose. The outputs of the power amplifier should be connected to the terminals of the RM-610 marked 1, 2 and 3. Connect the loudspeakers to the "Common" terminals of the RM-610.

When the Output Selector buttons on the 610 are depressed, the RM-610 will

Precautions

switch the outputs of the selected power amplifier to the loudspeaker system. If the power amplifiers differ in overall gain, the Level Matching Controls on the rear of the 610 should be used to match the listening levels. This will ensure the fairest possible A-B (-C) listening comparison.

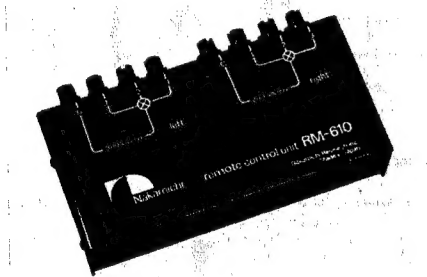

RM-610 Remote Control Unit

In order to avoid possible damage to the various components of your music system it is strongly advised that you observe the following precautions:

- Make sure that the AC power to the 610 and all other components is shut off before altering any of the interconnections.
- Always turn the Master Level Control to its fully counter-clockwise position when lowering or raising the tonearm of your record player, removing or installing a plug-in type phono cartridge headshell, turning the power on or off on electret or condenser microphones, or, in general, doing anything that may introduce a suddenly large signal to the power amplifier and the loudspeakers.
- Never plug components that draw more than a total of 350 VA into the AC outlets on the rear panel of the 610.
- It is a good idea to keep the Tone Level Control at minimum whenever test tones are not being used. Otherwise, the push of a wrong button may cause an unwanted test tone to damage your loudspeakers. Although this is highly unlikely, it is not entirely impossible.
- Before turning the power on, make sure the Master Level Control and the Monitor Volume Control are at minimum.
- It is a good idea to wait approximately twenty seconds after turning the 610 on to allow all circuits in your music system to stabilize before turning the volume controls up.

Using The 610 as a Preamplifier

The following section deals with the use of the 610 as the stereo control preamplifier in a music system, namely the playing and recording (dubbing) of the various sources connected to the 610, such as disc, tuner, tape, etc.

The operation of the 610 is not nearly as complicated as it might first appear. The seemingly formidable rows of pushbuttons and knobs are actually very logically laid out. Although the 610's controls differ significantly from those of conventional stereo preamplifiers in a number of aspects, the similarities are sufficiently numerous so that anyone with a moderate amount of experience in using stereo components will be able to quickly master the operation of the 610.

The controls of the 610 are basically divided into three sections: the input selection and control section, the function selection section, and the output control section.

The first section consists of the central portion of the 610 front panel with the two rows of selector buttons (Line A and Line B), the five smaller volume controls (Line A Level Controls, Blend Mic Level Control, and Line B Level Controls), and the Master Level Control at bottom left. The thing to remember is that "Line A" and "Line B" do not refer to the left and right channels. They are two independent stereo lines within the 610. The Line A and Line B selector rows correspond to the input selector knob on most preamps, amplifiers, or receivers; it is, however, as if the preamp had two selector knobs instead of one. The smaller volume controls allow adjustment of the level of the inputs selected for Line A and Line B (the Blend Mic Level control in the middle is for that input only). The Master Level Control is used to adjust the final input level and to perform fade-ins and fade-outs for tape recording.

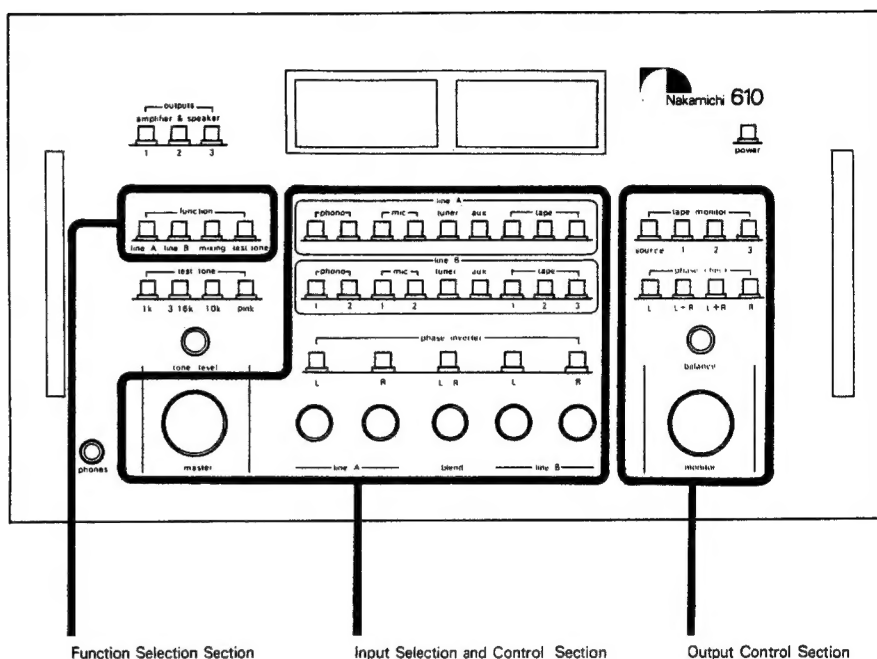

The function selection section consists of the Function Selector buttons near the top left of the 610 front panel. These will determine whether the input selected for Line A or the input selected for Line B is to be played (recorded), or whether both Lines are to be mixed (see page 13), or whether the test tones are to be used.

The output control section consists of the controls at the far right of the 610's front panel. The Tape Monitor Selector is normally set for "Source" unless the user wishes to monitor one of the recordings in progress. The Phase Check buttons are momentary contact switches and will be explained in later sections of this manual. The Balance Control is the same as in any preamplifier, amplifier or receiver. It is normally used in the center position and is adjusted only when an imbalance exists between the left and right channels. The Monitor Volume Control corresponds to

the "Volume" control on most other preamps, amplifiers or receivers. It controls the output level to the power amplifier and, therefore, controls the overall listening volume.

The following examples will illustrate typical usage of the controls described above.

EXAMPLE 1: Playing (and tape recording) a Phonograph Disc

1. After making sure that all the volume controls are fully counter-clockwise, turn the power to the 610 and other components on.
2. If using multiple speakers or power amplifiers (with the RM-610, see page 5), select the desired system by depressing the appropriate Output Selector button (depressing more than one Output button will cause the 610 to default to the lowest numbered output). If only one power amplifier and one loudspeaker pair is in use, make sure at least one of the Output buttons are depressed. Otherwise, there will be no output to the power amplifier. Also make sure that the Level Matching Control on the rear panel for the selected output is at maximum.
3. Depress the "Source" button on the Tape Monitor Selector.
4. Depress the Phono 1 button on the Line A selector row (or Phono 2 if the record to be played is on a turntable plugged into the Phono 2 input jacks of the 610).
5. Depress the Line A button on the Function Selector row.
6. Turn both left and right Line A Level Controls to about 2 o'clock.
7. Lower the tonearm onto the record.
8. Turn the Master Level Control to about -10.
9. Slowly turn the Monitor Volume Control up. The record should now be heard through the loudspeakers.
10. Fine adjustments in volume and balance may be made with the Line A Level Controls and the Master Level Control. Use the Peak Level Meters as a guide (average levels should read between -10 to 0 dB).
11. Always turn the Master Level Control fully counter-clockwise before lifting the tonearm from the record.

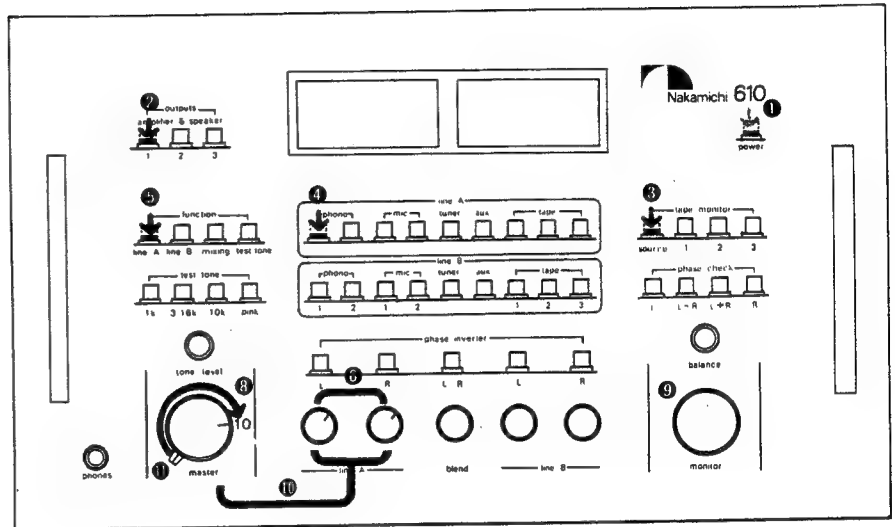

Note:

- A) The procedure for listening to a tuner or any other source connected to the 610's input jacks is exactly the same as outlined above except that the appropriate button on the Line A Selector row should be depressed instead of Phono 1 (or 2).
- B) It is possible to obtain identical results by utilizing the Line B selector row, the Line B button on the Function Selector row and the Line B Level Controls. If, however, the same input is selected for both Line A and Line B (e.g., pushing the Phono 1 buttons on both Line A and Line B selector rows), only Line A will be operational.
- C) A tape recording of the source being played may be made on any or all of the tape decks connected to the Play-In/Rec-Out jacks of the 610. Use the Master Level Control as a record level master for fade-in and fade-out effects. Any recording in progress may be monitored by depressing the appropriate Tape Monitor Selector button. The Phase Check buttons, Balance Control and Monitor Volume Control will affect neither the outputs to any

of the tape decks nor the Peak Level Meters on the 610. The Tape Monitor selector buttons will not affect the outputs to any of the tape decks, but they will cause the Peak Level Meters to read either "Source" or one of the tape deck outputs, whichever is selected.

EXAMPLE 2: Playing (and dubbing) a Previously Recorded Tape

Method (1)

1. Repeat steps one and two of Example 1.
2. Depress the appropriate button on the Tape Monitor Selector.
3. Put the tape deck into the PLAY mode.
4. Slowly turn the Monitor Volume Control up. The tape should now be heard through the loudspeakers. The Peak Level Meters on the 610 will read the output from the tape deck.

Method (2)

An alternate method is as follows:

1. Repeat steps one, two and three of Example 1.
2. Depress the appropriate Tape button on the Line A (or Line B) selector row.
3. Depress the Line A (or Line B, if this was selected in step 2 above) button on the Function Selector row.
4. Turn both left and right Line A (or Line B, if this was selected in step 2 above) Level Controls to about 2 o'clock.
5. Start the tape deck.
6. Turn the Master Level Control to an appropriate level using the Peak Level Meters as a guide (average levels should read between -10 and 0 dB).
7. Turn the Monitor Volume Control to the desired listening level.

Note:

- A) When dubbing from one tape deck to another, employ the latter method above. The playback tape deck should be treated as the "Source" deck in example 2 above. The record tape deck, then, is either or both of the two remaining tape decks. When dubbing from deck 1 to deck 2, for example,

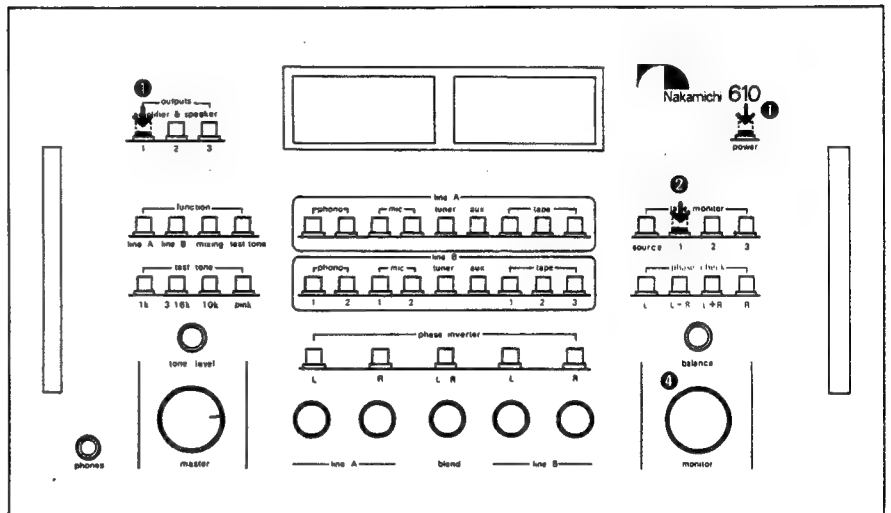

Method (1)

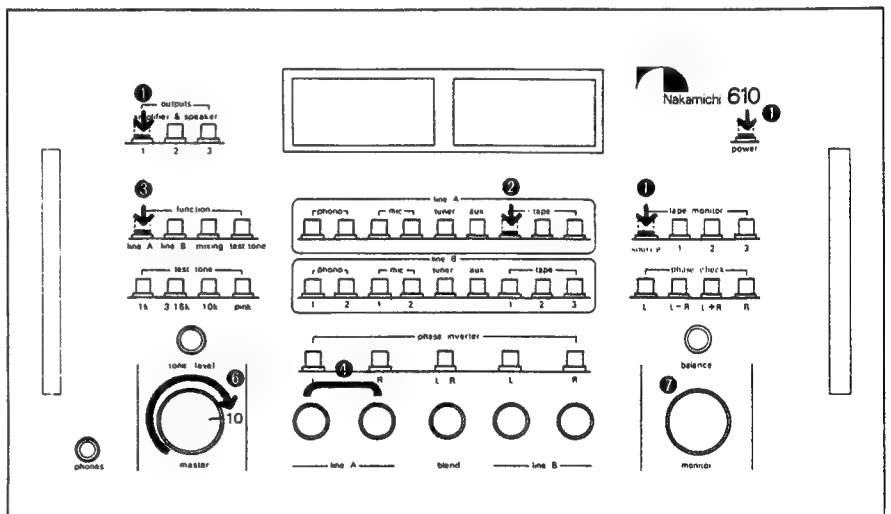

Method (2)

follow steps 1 through 7 above noting that the appropriate button to depress in step 2 is "Tape 1" on the Line A (or B) selector row. Step 3 would be to begin recording on deck 2, having set the proper record levels with the input level controls on deck 2 and/or the Master and Line A (or B) Level Controls on the 610.

B) When a tape button is depressed on either the Line A or Line B selector row, the input to that tape deck is blocked to avoid feedback "howl."

Using The 610 as a Performance Checker

The 610 incorporates a low distortion sine wave oscillator, pink noise generator, two precision peak level dB meters and input/output comparison switching features that can be used in a variety of ways to verify the performance as well as aid in the adjustment and calibration of stereo system components. The following are examples of the 610's capabilities as a performance checker and analyzer.

Frequency Response Testing

1. Playback frequency response of tape decks or frequency response of phono cartridges may be verified by playing standard test tapes or test records that contain a series of tones. The levels of these tones can be monitored on the Peak Level Meters of the 610. Set the controls on the 610 as you would to listen to the tape deck or record player. Adjust the Line A (or B) Level Controls and the Master Level Control to convenient points on the Peak Level Meters.
2. Record/Playback frequency response of tape decks may be checked by recording the Test Tones generated by the 610 and then observing the playback levels on the Peak Level Meters.
 - a) Depress the Test Tone button on the Function Selector row.
 - b) Depress the 1K button on the Test Tone Selector row.
 - c) Turn the Tone Level Control to approximately 12 o'clock.
 - d) Make sure the Monitor Volume Control is at minimum, then turn the Master Level Control to its maximum position ("0"). If desired, the Monitor Volume may be slightly raised so that the tone can be heard softly through the loudspeakers. If the Peak Level Meters do not give any indication of the tone and there is no tone through the loudspeakers when the Monitor Volume is raised, check to make

sure that the Tape Monitor Selector is at "Source", and that the Tape button on either the Line A or Line B Selector is not set for the tape deck under test.

- e) Put the tape deck under test into the Record mode, and adjust the input level controls on the deck so that the 1K tone is being recorded at -10 dB or -10 VU for open reel and -20 dB or -20 VU for cassette on the tape deck's record level meters. Re-adjust the Tone Level control on the 610 if necessary.
- f) If the deck is a three-head machine, put the Monitor switch on the deck to the "Tape" position. If it is a two-head device record the tone for a while, then rewind and replay the tone.
- g) Push the Tape Monitor button on the 610 for the tape deck under test.
- h) Adjust the output level controls on the tape deck so that the Peak Level Meters on the 610 read at convenient points.
- i) On the two-head machine, return to the Record mode.
- j) For three-head decks the frequency response may now be checked by switching through the seven frequencies available on the 610 (1K, 3.16K, 4.16K, 10K, 11K, 13.16K, 14.16K Hz) in ascending order. This is done by using the three Test Tone buttons on the left in an additive fashion. Pushing the 1K button and the 10K button simultaneously, for example, will yield an 11K tone. The playback level for each frequency and each channel can be observed on the 610's peak level meters.
- k) For two-head decks, it will be necessary to first record the seven tones in sequence (five to ten seconds for each tone). The frequency response can then be checked dur-

ing playback of the recorded tones. A tape deck with uniform frequency response will give approximately equal readings on the Peak Level Meters of the 610 for all frequencies.

Note: Record levels other than those specified in step e) may be selected to test the tape deck's headroom response.

3. Frequency response (and certain other parameters) may be checked aurally using pink noise. Follow the procedure above substituting pink noise for the individual sine wave tones. During playback of the recorded pink noise, switch between "Source" and the deck using the Tape Monitor Selector buttons on the 610. Listen to the pink noise over the loudspeakers to determine if there is any change in the "character" of the pink noise. The levels for "Source" and the deck should be matched using the output level controls on the tape deck and the Peak Level Meters on the 610. This is an extremely difficult test for any tape deck. If a tape deck cannot satisfactorily reproduce the pink noise for any given record level, repeat the test at a lower record level.

Tape Deck Adjustment and Calibration

If the frequency response of the tape deck as tested in the above manner is not uniform, it may be an indication that the deck is out of adjustment or alignment for the particular tape in use. First, check to make sure that the tape used for the test is the one for which the deck was factory adjusted. If it is determined that the deck is in need of adjustment, the instruction manual and/or service manual for that unit should be consulted. Adjustments that affect frequency response, such as bias current, record/playback equalization, head alignment, etc., are, generally speaking, not user adjustable. Many of these adjustments are not readily accessible and may require the use of special tools, test tapes and test instruments not incorporated in the 610. If the tape deck's instruction manual does not explain the procedure for any given adjustment, it is best to leave such adjustment in the hands of qualified service personnel.

Pink Noise Testing of Loudspeakers

Pink noise testing can be very revealing of the different colorations that many loudspeakers exhibit. Although it takes a trained ear to detect the exact nature of a loudspeaker's inaccuracies by listening to pink noise, it is not difficult to hear the difference in "character" between two loudspeakers reproducing pink noise. In order to perform this test, it is necessary to utilize the RM-610 optional Remote Control Unit as described on page 5.

1. Make sure the Monitor Volume Control is at minimum.
2. Depress the "Source" button on the Tape Monitor Selector row.
3. Depress the Test Tone button on the Function Selector row.
4. Depress the "Pink" button on the Test Tone Selector row.
5. Turn the Tone Level Control to approximately 12 o'clock.

6. Turn the Master Level Control to -10.
7. Select one of the loudspeakers to be tested with the Output Selector.
8. Turn the Monitor Volume Control to the desired listening level.
9. Switch loudspeakers using the Output Selector buttons.

The listening levels of the different loudspeakers should be equalized using the Level Matching Controls on the rear panel of the 610.

Utilizing the Peak Level Meters

The "VU" level meters on many open reel and cassette tape decks are not "fast" enough to give accurate indications of musical peaks. The illustration points to the fact that there can be as much as 8 dB difference between a Peak reading meter and a VU meter on an instantaneous signal even though the two meters give the same reading on a continuous signal. The Peak Level Meters on the 610 can be used to determine the ability of a tape deck's meters to accurately indicate instantaneous peaks.

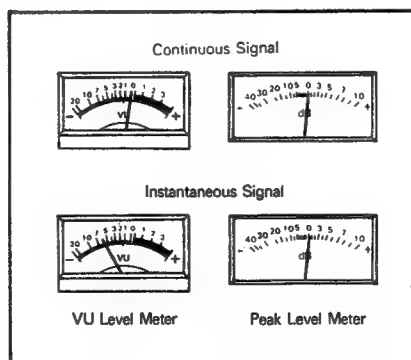

1. Make sure the Monitor Volume Control is at minimum.
2. Depress the "Source" button on the Tape Monitor Selector.
3. Depress the Test Tone Button on the Function Selector.
4. Depress the 1K button on the Test Tone Selector.
5. Turn the Master Level Control to maximum ("0").

6. Adjust the Tone Level Control for a -10 dB reading on the Peak Level Meters.
7. Adjust the input level controls on the tape deck for a -10 dB (or -10 VU) reading - it may be necessary to put the deck into the record mode in order to activate the level meters.
8. Switch the Function Selector from Test Tone to either Line A or Line B.
9. Select a source (phono, tuner, etc.) on the appropriate Selector row and begin recording the source material on the tape deck.
10. Do not adjust the recording level with the controls on the tape deck. Adjust only with the Master Level or the appropriate Line Level Controls on the 610. This will assure that the 610's Peak Level Meters will be in calibration with the tape deck's level meters. If the deck's meters are not of the Peak indicating type, the difference between the readings on the deck's meters and the 610's meters will be immediately obvious.

Phase Checking

Components in a stereo system with the left and right channels wired out of phase can cause cancellation (and therefore thinness) of the bass frequencies and poor stereo imaging. The four Phase Check buttons on the 610 are momentary contact switches (they will return to the off position unless held down) that operate in five modes to permit the verification of phase as well as other parameters, such as channel balance and left-right identification.

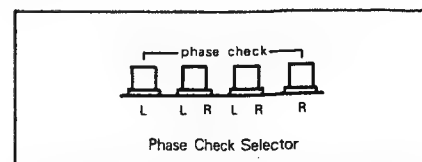

1. Depressing the "L" button will cause the left channel program material to appear at both channels.

2. Depressing the "L-R" button will cause a signal that is the arithmetic difference between the left and right inputs to appear at both channels.
3. Depressing the "L+R" button will cause the sum of the left and right inputs to appear at both channels.
4. Depressing the "R" button will cause the right channel program material to appear at both channels.
5. Depressing both the "L" and the "R" buttons simultaneously will cause the left and right channels to become reversed.

The phase check buttons, if should be noted, affect only the Monitor and Headphone Outputs. They will not affect the Rec Out or Line Out.

Phono Phasing

In order to check whether a phono cartridge or tonearm is correctly wired with respect to phase, for example, the following procedure may be followed:

1. Play a test record containing pink or white noise or single tones. If such a test record is not available, any monaural record will suffice.
2. Assuming all controls on the 610 are properly set for the playing of a phonograph record (see page 8) and that the Balance Control is at its center position, depress the "L-R" phase check button.
3. If the cartridge and tonearm are properly wired, the sound from the loudspeakers should become extremely faint. If not, try adjusting the Balance Control until the output from the loudspeakers is minimal. If the point of minimum output is far removed from the Balance Control's center position, this means that the cartridge/tonearm is correctly wired but that the outputs from the turntable are not equal in intensity. If it is not possible to obtain a minimum sound output, this is an indication that the cartridge or tonearm is wired out of phase.

Consult the user's instructions for the respective components.

Loudspeaker Phasing

The phasing of the stereo loudspeakers can easily be checked in the following manner:

1. Using the built-in pink noise generator, reproduce the pink noise through the loudspeakers at a moderate level.
2. With the Balance Control at its center position listen at a point halfway between the two loudspeakers.
3. Assuming there are no problems with channel balance, the pink noise should be coming from a point between the two speakers if they are connected in phase. If the pink noise appears to be coming from all directions (or from no direction in particular), chances are that the loudspeakers are connected out of phase.
4. If it is determined that the loudspeakers are out of phase with each other, reverse the connections at the amplifier or at the loudspeaker for one channel only. Then, repeat the above test.

Note: This test will be extremely difficult to perform with loudspeakers that do not produce a fairly precise stereo image (such as reflecting type loudspeakers).

A-B Comparison Testing

One of the most useful features of the 610 is the ability to perform A-B listening comparisons of various components connected to it. By using the RM-610, for example, the A-B comparison of loudspeakers with preamp level output matching becomes a simple matter of pushing the appropriate Output Selector buttons on the 610 (see page 5). Other examples, that do not require the optional Remote Control Unit, are described below:

1. Phono Cartridge comparison

Two phono cartridges playing two identical records (or playing the same record if a turntable with two tonearms is available) can be compared by utilizing both phono inputs on the 610. Program phono 1 through Line A, and phono 2 through Line B (depress the Phono 1 button on the Line A selector row and the Phono 2 button on the Line B selector row). Make sure the proper impedance is selected for each cartridge. The levels should be set using the Line A and Line B Level Controls so that the outputs of both cartridges are matched. The A-B comparison can be performed by alternately pushing the Line A and Line B buttons on the Function Selection row.

2. Tape-Source Comparison

A good test of a tape deck's performance is to compare a recording made on that deck to the original source material, which may have been a phonograph disc or another tape. For example, in order to evaluate a recording made on Tape Deck 1 of a disc played on Phono 1, the following procedure would be applied:

- Program Phono 1 on the 610 as you would to play a record.
- Depress Tape Monitor 1 and start Tape Deck 1.
- Stop the deck (use the Pause feature if provided) as soon as the music begins.
- Switch to "Source" on the 610 and begin playing the disc that was recorded.
- As soon as the music begins, re-start the tape deck.

The Tape-Source comparison can now be made by alternately depressing the "Source" and Tape Monitor 1 buttons on the 610. Levels between Tape and Source may be matched with the Master Level Control or the tape deck's output control.

In similar ways it is possible to conduct the A-B comparison of power amplifiers, tape decks, tuners, etc.

Using The 610 as a Mixer

The 610 is an extremely low-noise/low-distortion mixer. It allows the stereo mixing of any five of the 19 inputs to the 610 (the center channel is always the Blend Mic). Using the 610, therefore, it is possible to perform live or pre-recorded source mixing in a variety of combinations. Some examples are given below.

1. 5 Microphone Live Recording

Connect the microphones to the input panel of the 610. Make sure all Mic Input Attenuators are at the "0 dB" position. Also make sure microphone switches, if any, are on.

- 1) Depress the "Source" button on the Tape Monitor Selector row.
- 2) Depress "Mic 1" on the Line A selector row.
- 3) Depress "Mic 2" on the Line B selector row.
- 4) Depress the "Mixing" button on the Function Selector.
- 5) Turn the Master Level Control to approximately -10.
- 6) The individual microphone input levels should be adjusted using the Line A, Line B and Blend Mic Level Controls. If necessary, activate the Mic Attenuators with the appropriate switches on the rear panel of the 610.

Note: If all five microphones are not of the same manufacturer, there is a remote possibility that their phase may not be uniform. In order to check the phase uniformity between two microphones, place

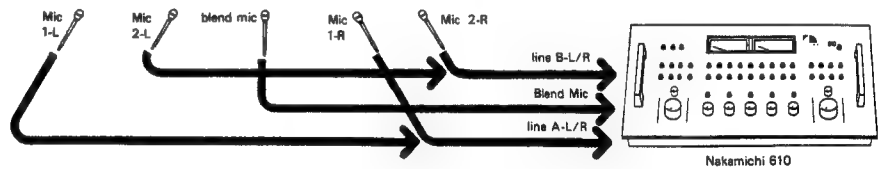
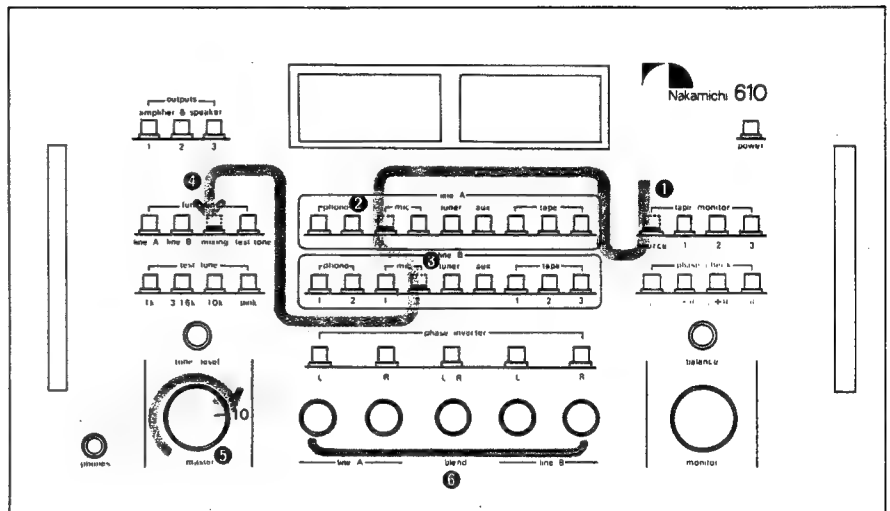

them next to each other and near a relatively directional sound source, such as a person speaking (see illustration). If the two microphones are out of phase, there should be cancellation when the "A+B" Phase Check button is depressed (this can be heard over stereo headphones plugged into the 610). If there is cancellation

when the "A-B" Phase Check button is depressed, the two microphones are in phase. The phase for any of the five microphones may be inverted by depressing the Phase Invert button on the 610 for that input. The Phase Invert buttons are active only in the "Mixing" function.

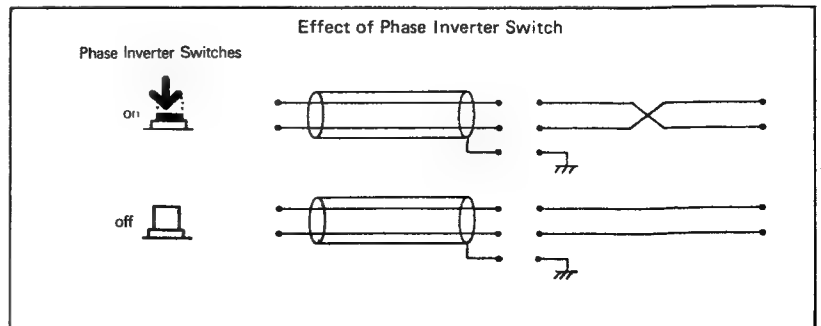
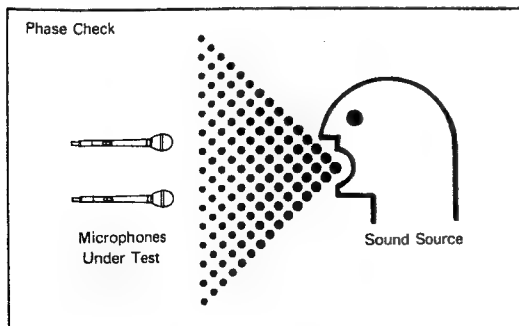

2. Mixing 3 Microphones and 1 Stereo Tape Deck

Plug the microphones into the two Mic 1 inputs and the Blend Mic Input.

- 1) Depress the "Source" button on the Tape Monitor Selector.
- 2) Depress "Mic 1" on the Line A selector.
- 3) Depress the appropriate Tape button on the Line B selector.
- 4) Depress the "Mixing" button on the Function Selector.
- 5) Turn the Master Level Control to approximately -10.
- 6) The individual input levels should be adjusted using the Line A, Blend Mic and Line B Level Controls.

If necessary, activate the Mic Attenuators for the three microphones with the appropriate switches on the rear panel of the 610. Also check the mic phasing as described in Example 1.

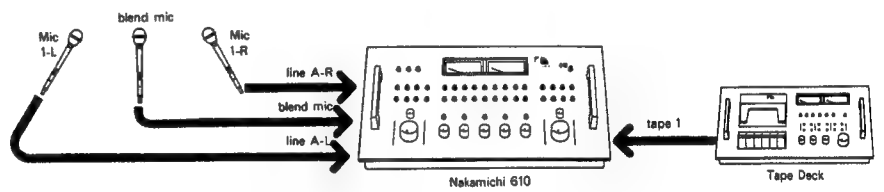
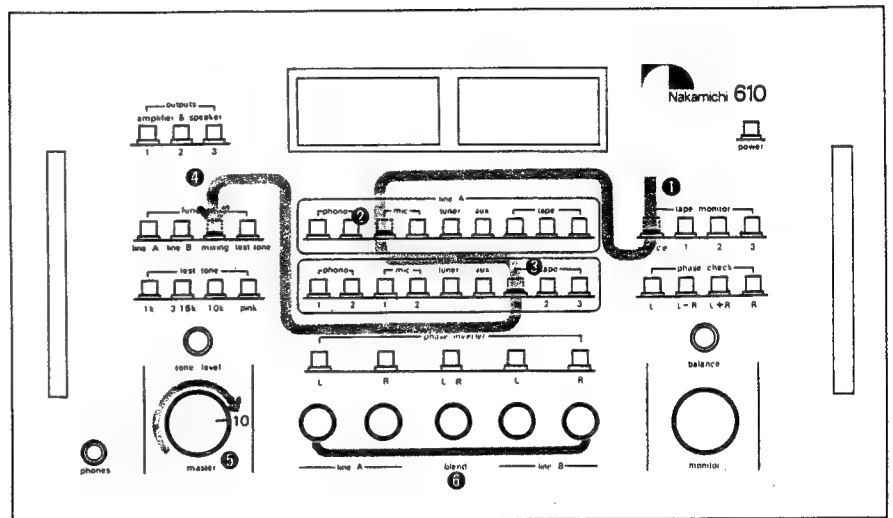

3. Mixing 3 Microphones and 1 Record Player

The procedure is identical to that for Example 2 above except that the appropriate Phono (rather than Tape) button should be depressed on the Line B selector row.

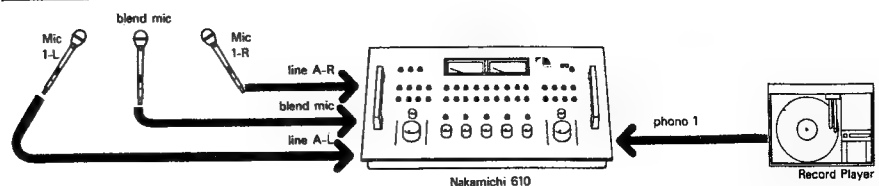
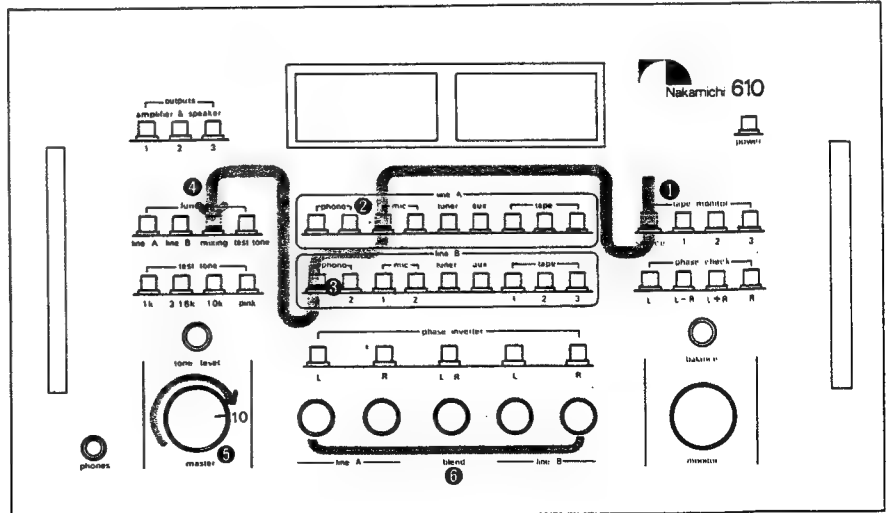

4. Mixing 2 Tape Decks and Blend Mic

The single microphone should be plugged into the 610's Blend Mic Input.

- 1) Depress the "Source" button on the Tape Monitor Selector.
- 2) Depress the appropriate Tape button for the first tape deck on the Line A selector row.
- 3) Depress the appropriate Tape button for the second tape deck on the Line B selector row.
- 4) Depress the "Mixing" button on the Function Selector.
- 5) Turn the Master Level Control to approximately -10.
- 6) Adjust the tape deck levels using the Line A and Line B Level Controls.
- 7) Adjust the microphone level with the Blend Mic Level control.

Note: In the example illustrated, Tape Decks 1 and 2 are used as sources. Tape Deck 3, therefore, would be used to record the mix.

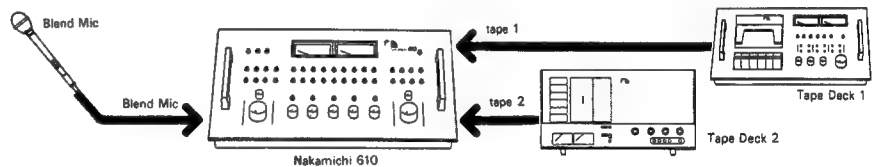
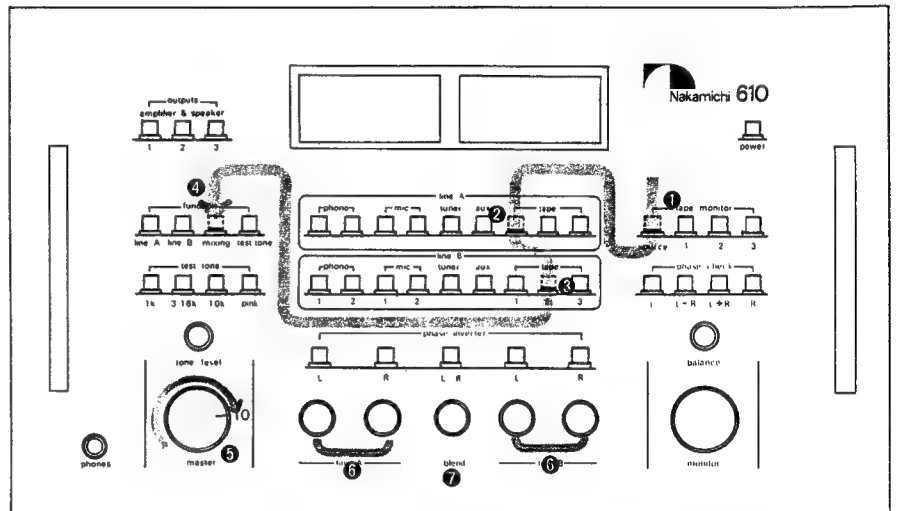

5. Mixing 1 Record Player, 1 Tape Deck and Blend Mic

- 1) Depress the "Source" button on the Tape Monitor Selector.
- 2) Depress the appropriate Phono button on the Line A selector row.
- 3) Depress the appropriate Tape button on the Line B selector row.
- 4) Depress the "Mixing" button on the Function Selector.
- 5) Turn the Master Level Control to approximately -10.
- 6) Adjust the individual input levels with the Line A, Blend Mic and Line B Level Controls.

If necessary, activate the Mic Attenuator for the Blend Mic.

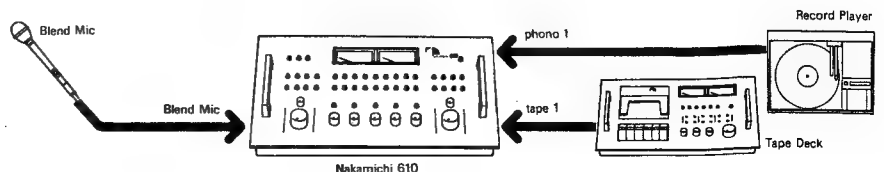
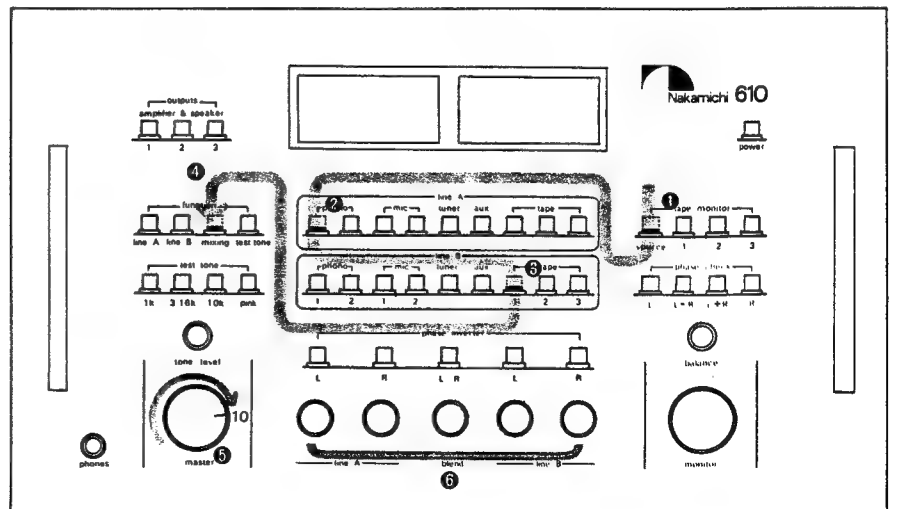

6. Mixing 2 Tape Decks

The procedure is basically the same as that for example 4 except that the Blend Mic Level Control is not used in this case. The illustration shows Tape Decks 1 and 2 as the sources for a recording to be made on Tape Deck 3.

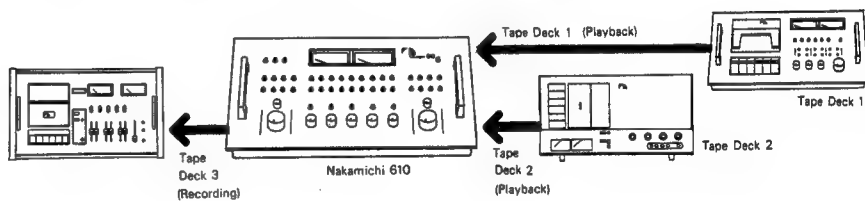
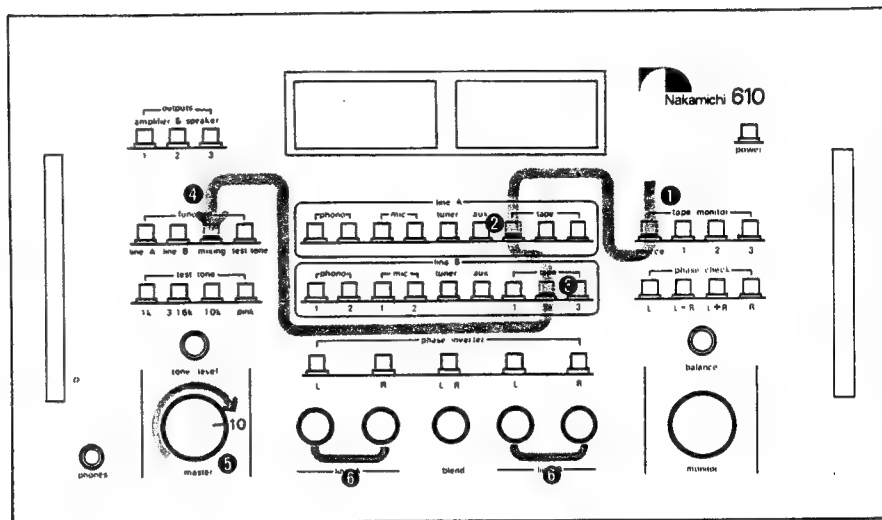

Note:

- A) If, when using the 610 as a mixer, it is desired to record or test Line A without Line B, or vice versa, such as for level setting or cueing, the Function Selector should be utilized. Note, however, that selecting Line A or Line B will cut off the Blend Mic and render the Phase Invert buttons inoperative.
- B) It is a good idea, when making a live recording or any tape recording that is likely to be played back on a deck other than the one on which it was recorded, to record a 1K tone at 0 dB and a high frequency tone (10K – 14K) at –10 or –20 dB onto the tape before proceeding with the recording. These reference tones can, of course, be generated by the 610, and they will come in handy when dubbing or replaying the tape on a different tape deck at some future date.

Block & Level Diagrams

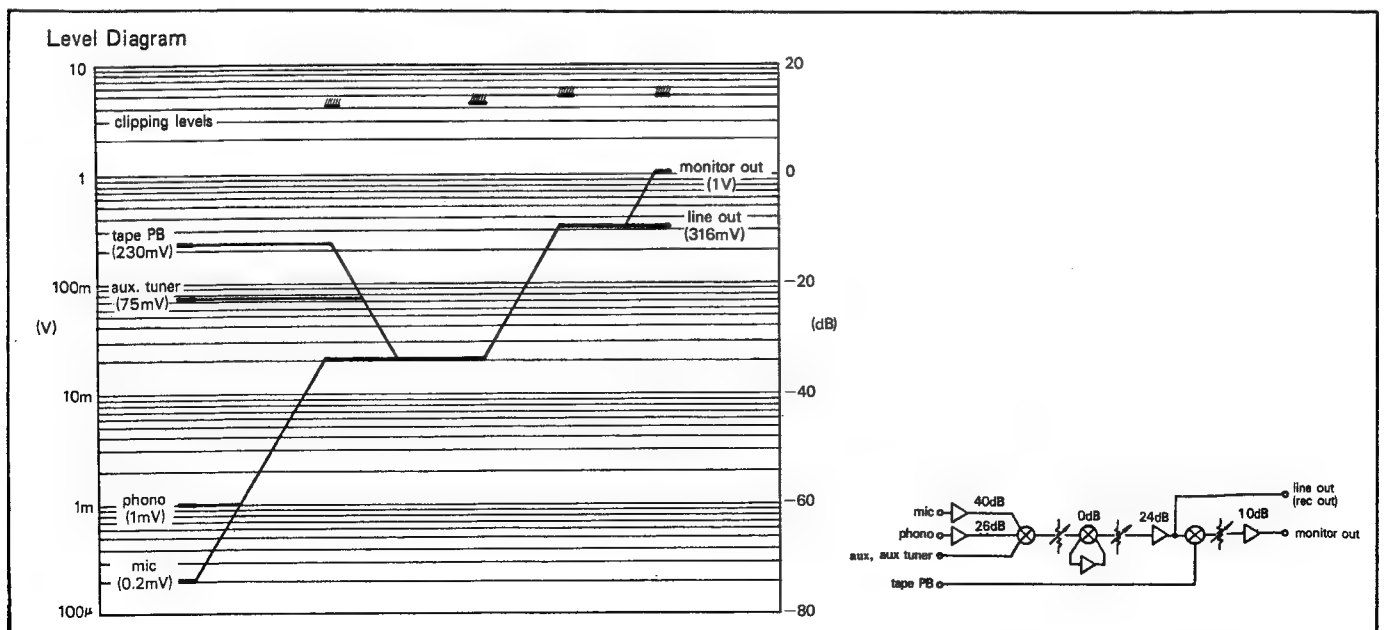
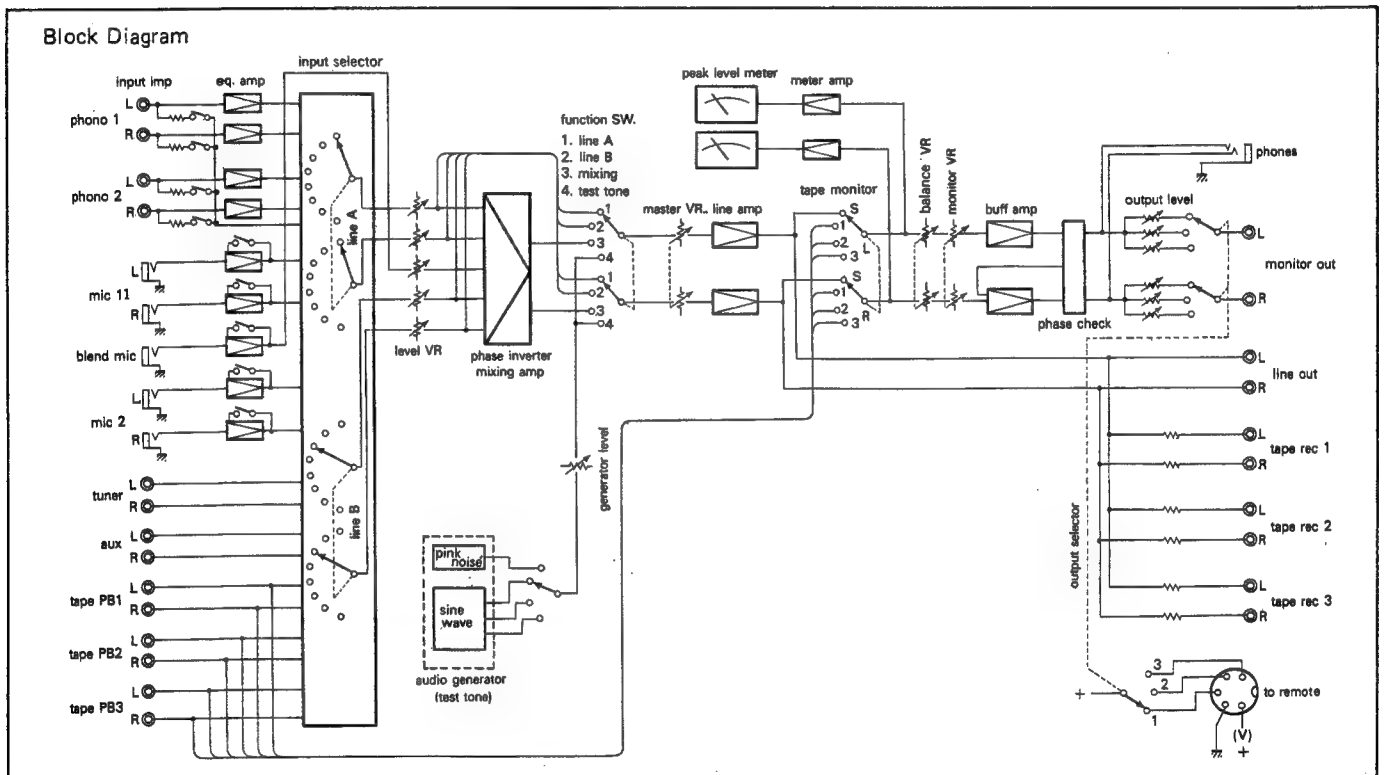

Trouble Shooting Chart, Service Information

Condition	Probable Cause	Remedy
No sound	<ol style="list-style-type: none"> 1. None of the Output Selector buttons are depressed. 2. None of the Function Selector buttons are depressed. 3. Poor cable connections. 4. Volume controls are not raised. 	<p>One of the Output Selector buttons must be depressed at all times. Depress the desired Function button.</p> <p>Check all cable connections. Check the Line A and/or Line Level Controls as well as the Master Level and Monitor Volume Controls.</p>
Distortion, hum or noise in Phono	<ol style="list-style-type: none"> 1. Poor cable connections. 2. Poor grounding. 3. Impedance mismatch. 4. Poor connections at cartridge/tone-arm. 	<p>Check all phono cable connections. Check ground wire connections. Select proper phono input impedance. Check all cartridge and tonearm contacts.</p>
Distortion, hum or noise in Mic.	<ol style="list-style-type: none"> 1. Mic preamp overload. 2. Poor cable connections. 3. Wrong wiring of connector. 	<p>Activate 15 dB or 30 dB Mic Attenuator as required. Check all Mic cable connections. Re-wire or replace connector.</p>
Channels reversed or one channel dead	<ol style="list-style-type: none"> 1. Input/output jacks reversed or loose. 2. Balance control not centered. 	<p>Check all cable connections. Re-adjust Balance Control.</p>

SERVICE INFORMATION

Although it is unlikely that your Nakamichi 610 will require repair, should servicing ever become necessary, please consult your Nakamichi dealer or the Nakamichi dealer closest to you. As there are no user serviceable parts inside the unit, please do not attempt your own repairs.

Please read all accompanying Warranty Cards and/or notices very carefully.

Thank you for your confidence in Nakamichi products.

Performance Data

RIAA Equalizer Amp. (Phono)
 Input vs
 Total Harmonic Distortion
 Line Output: 2 V Constant
 H.P.F.: 400 Hz
 L.P.F.: 80 KHz in

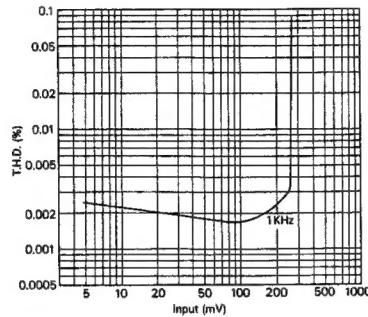

RIAA Equalizer Amp. (Phono)
 Frequency vs
 Total Harmonic Distortion
 Line Output: 2 V Constant

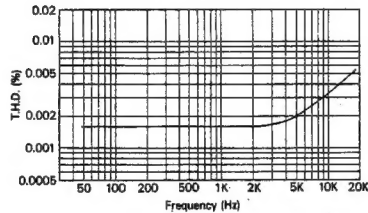

RIAA Equalizer Amp. (Phono)
 Input Impedance vs
 Noise Level

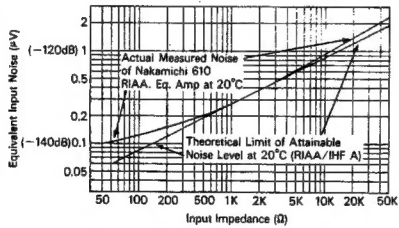

RIAA Equalizer Amp. (Phono)
 Noise Characteristics
 Frequency vs
 Noise Level

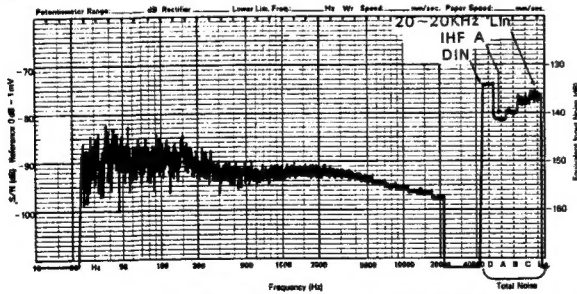

Pink Noise Generator
 Characteristics
 1/3 Octave Analysis

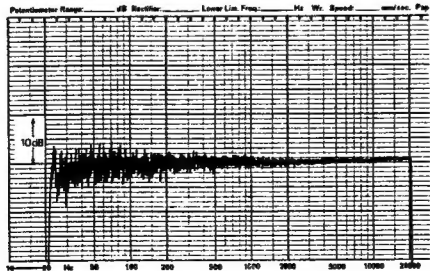

Microphone Amp.
 Input vs
 Total Harmonic Distortion
 Frequency: 1 KHz
 Line Output: 2 V Constant
 H.P.F.: 400 Hz
 L.P.F.: 80 KHz

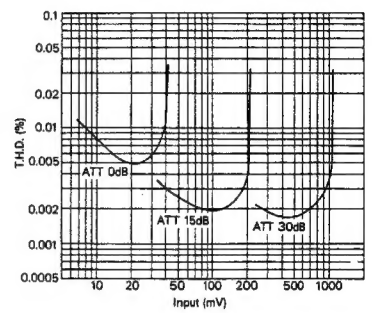

Microphone Amp.
 Frequency vs
 Total Harmonic Distortion
 Att.: 15 dB
 Master VR: -20 dB
 Line Output: 1 V Constant
 L.P.F.: 80 KHz

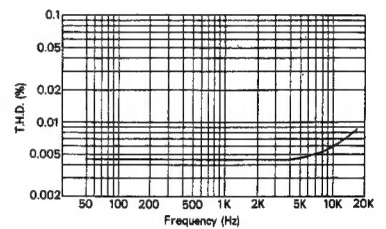

Monitor Amp.
 Output vs
 Total Harmonic Distortion
 Input: Tape PB-1
 Output: Monitor Output
 H.P.F.: 400 Hz
 L.P.F.: 80 KHz

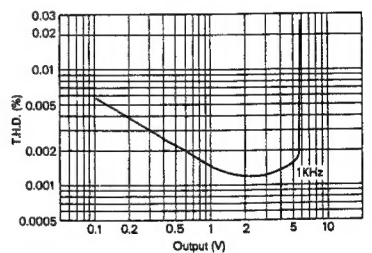

Monitor Amp.
 Frequency vs
 Total Harmonic Distortion
 Line Output: 2 V Constant
 Monitor VR: max.
 L.P.F.: 80 KHz

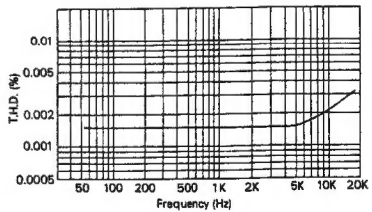

Headphone Amp.
 Output vs
 Total Harmonic Distortion
 Frequency: 1 KHz
 Load Impedance: 8 ohms

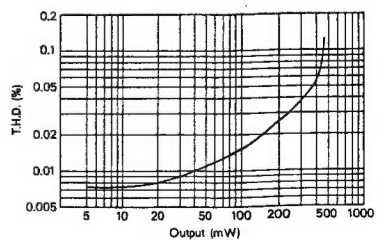

H.P.F. — High Pass Filter
 L.P.F. — Low Pass Filter

Specifications, Accessories

Specifications

Power Source	100-120/220-240V AC 50/60 Hz
Power Consumption	20 VA
Input Sensitivity/Impedance	
mic	0.2 mV/1 K ohms (attenuators: 15, 30 dB)
phono	1 mV/200, 50K, 100K ohms
aux, tuner	75 mV/25K ohms
tape PB	230 mV/75K ohms
tape monitor	316 mV/75K ohms
Maximum Input Levels	
mic	1 V (+74 dB) ... Att: 30 dB
phono	250 mV (+48 dB)
aux, tuner, tape PB	50 V
Output Levels (@ 0 dB)/Output impedance/min. load impedance	
monitor out	1 V/100 ohms/1 K ohms
line out	316 mV/600 ohms/10K ohms
rec out	316 mV/2.2K ohms/50K ohms
headphone	40 mW/8 ohms/8-200 ohms
Maximum Output at Clipping	
monitor out	5V into 1 K ohms
line out	5V into 10K ohms
rec out	5V into 50K ohms
headphone	300 mW into 8 ohms
Frequency Response	
mic	30-100,000 Hz +0, -1.5 dB
phono	30-15,000 Hz ±0.3 dB
aux, tuner	20-100,000 Hz +0, -1.5 dB
tape PB	10-50,000 Hz ±0.3 dB
monitor out	5-150,000 Hz +0, -1.5 dB
Signal-to-Noise Ratio (IHF A) — (ref. level)/equivalent input noise	
mic	better than 53 dB (0 dB)/-127 dB (65 dB; Att: 15 dB)
phono	better than 80 dB (1 mV)/-140 dB (90 dB @ 3mV)
aux, tuner, tape PB	better than 85 dB (Master @ max) better than 93 dB (Master @ min)

Residual Noise Level (IHF A)	
headphone (8 ohms)	4 microvolts or less
line out	7 microvolts or less (Master @ min) 15 microvolts or less (Master @ -30 dB)
Distortion (Master Vol. @ -20 dB, Level Vol. @ max, line out @ 2V)	
mic	less than 0.01% at all freq. up to 10 KHz
phono	less than 0.005% at all freq. up to 10 KHz
aux, tuner, tape PB	less than 0.005%
Test Tones	
sine wave oscillator	1K, 3.16K, 4.16K, 10K, 11K, 13.16K, 14.16K Hz (all possible combinations)
pink noise generator	50-15,000 Hz ±2 dB (1/3 octave analysis)
sine wave distortion	1 KHz - 14.16 KHz less than 0.2%
Peak Level Meters (2)	
range	-40dB to +10 dB
accuracy	-20 dB to +10 dB ±1 dB -40 dB to -20 dB ±2 dB
frequency response	50-20,000 Hz +0, -1 dB (-30~+10 dB)
Semiconductor Complement	
FET's	3
transistors	134
diodes	27
zener diodes	5
integrated circuits	2
Miscellaneous	
AC outlets	2, switched, 350 VA max.
dimensions	15.75 (W) x 6.70 (H) x 9.33 (D) inches 400 (W) x 170 (H) x 237 (D) m/m
weight	15-1/2 lbs. (7 kg)

• Specifications and appearance design are subject to change for further improvement without notice.

Dimensions

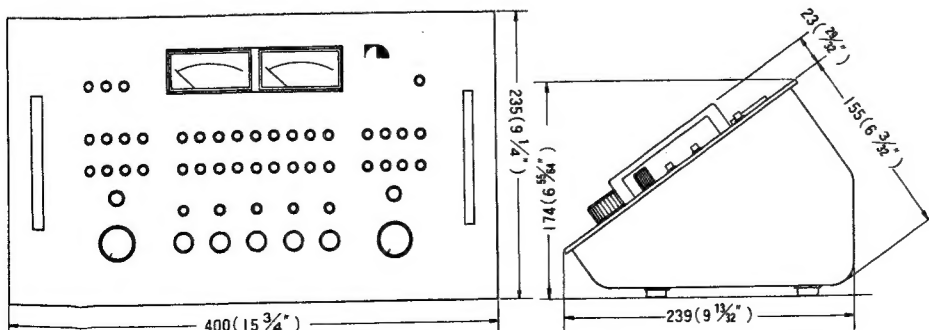

Accessory

RM-610 Remote Control Unit
(see page 5)

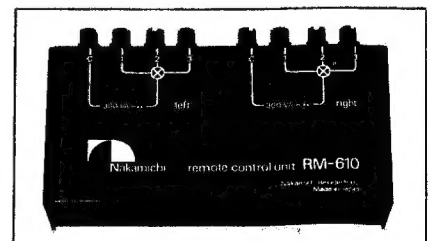

NAKAMICHI RESEARCH (U.S.A.), INC.
220 Westbury Avenue
Carle Place, N.Y. 11514
Phone: (516) 333-5440
Telex: 144513 (NAKREI CAPL)

NAKAMICHI RESEARCH (U.S.A.), INC.
1101 Colorado Avenue
Santa Monica, Calif. 90401
Phone: (213) 451-5901
Telex: 652429 (NAKREI SNM)

NAKAMICHI RESEARCH INC.
1-153 Suzukicho, Kodaira, Tokyo
Phone: (0423) 42-1111
Telex: 2832610 (NAKREI J)
Cable: NAKREI KKB