



Thanks for purchasing
this product!

boredbrain

MIND YOUR MUSIC

RICHMOND, VA | www.boredbrainmusic.com

Boredbrain Terminal

The Terminal adds routing flexibility to signal chains of guitar pedal effects, electronic instruments and other audio devices.

- Easily insert effects into primary signal paths
- Copy signals using half-normalled patch points
- Re-route signals to alternate destinations
- Balanced/stereo TRS connections

technical specs

- Aluminum enclosure
- 16 x 1/4-in TRS jacks (6.35mm)
- Dimensions: 4.5 x 3 x 2.5 in
- Weight: 9 oz (255 g)

limited warranty

This product is guaranteed to be free of functional defects for a period of 180 days from original purchase date. Proof of purchase is required for any warranty claim. Return shipping costs are covered by Boredbrain Music within the first 30 days of purchase only. Products with obvious signs of abuse or that have been modified by the end user, may not be covered under this warranty, at the discretion of Boredbrain Music.

service & inquiries

If you experience a problem with your Boredbrain product, or just want to share something interesting with us, please contact us at the link below and be sure to include your name, original purchase date, and a description of the problem you are experiencing. Then just hold tight, as we return most inquiries within 48 hours. We want to work with you to resolve your issue as soon as possible. Thanks.

www.boredbrainmusic.com/contact



HALF-NORMAL PATCHBAY HUB

USER GUIDE

basic operation

- Connect instrument source signals to inputs on right side
- Connect destinations to respective outputs on left side
- Insert effects and re-route signals using top jacks

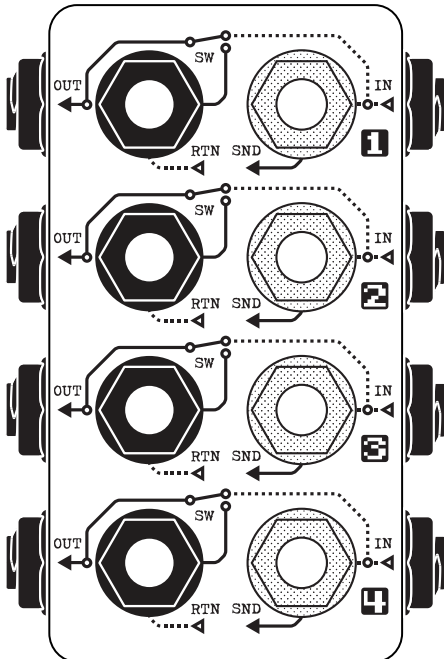

- COPY input signals using the Green SND jacks
- REPLACE signals to destinations using the RTN jacks

*Mute channel amplifiers to avoid pops while patching

pedalboard access points

Each Terminal channel is placed at specific points in the signal chain. New effects can then be inserted at these points, or entire sections can be bypassed using a single cable.

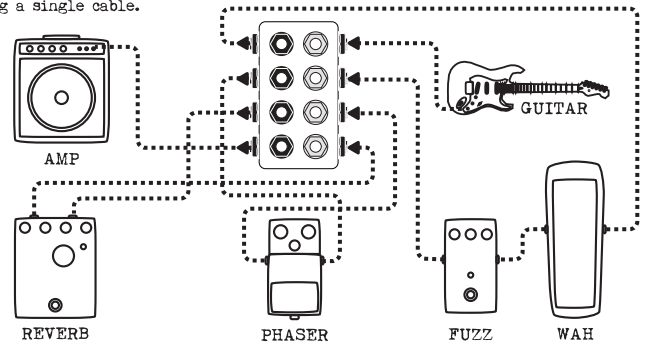

instruments patch hub

Each Terminal channel is a dedicated patch point for an instrument signal on its way to a mixer or DAW. Effects can be inserted into the signal easily, or it can be copied to another channel.

