

PSP 608 MULTIDELAY

8-Tap Multimode Delay Processor

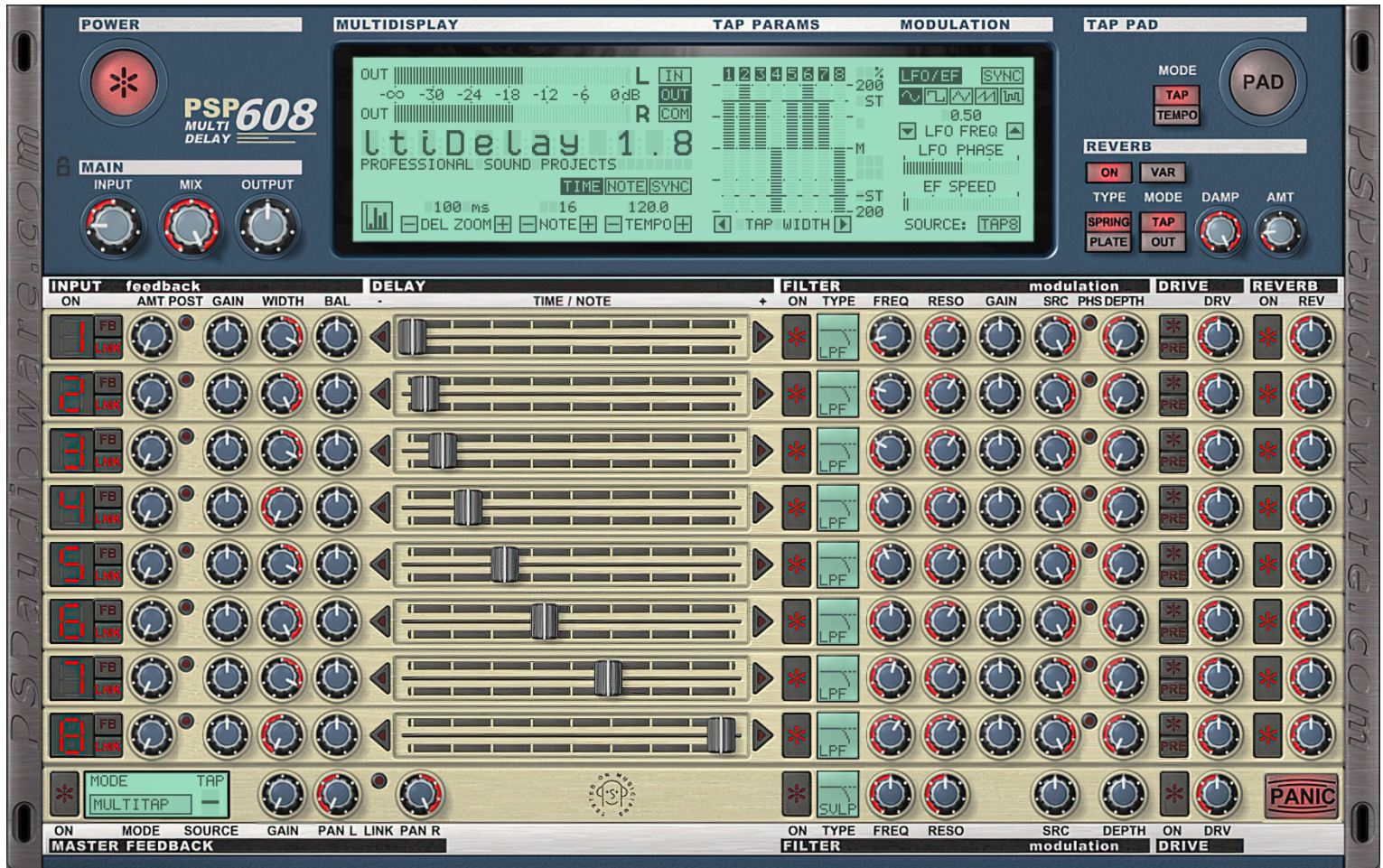

Operation manual

PSPaudioware.com

End User License Agreement

PREFACE: This End-User License Agreement (“EULA”) is a legal agreement between you and PSPaudioware.com s.c. (PSP) for the PSP product accompanying this EULA, which includes computer software and may include associated media, printed materials, and “online” or electronic documentation (“SOFTWARE”). By installing, copying, or using the SOFTWARE, you agree to be bound by the terms of this EULA. If you do not agree to the terms of this EULA, you may not use the SOFTWARE. The SOFTWARE is protected by copyright laws and international copyright treaties, as well as other intellectual property laws and treaties. The SOFTWARE is licensed, not sold.

LICENSE: You can INSTALL and USE the current version of the SOFTWARE, or in its place any prior version, on three computers simultaneously so long as you are the direct user or a studio client of those machines. If more users USE the software you must buy an additional license for each workstation. The DEMO VERSION of the SOFTWARE is NOT LICENSED FOR COMMERCIAL USE.

RESTRICTIONS: You may not transfer, modify, rent, lease, loan, resell, distribute, network, electronically transmit or merge the SOFTWARE. You may not reverse engineer, decompile or disassemble the SOFTWARE, or otherwise attempt to discover the SOFTWARE source code. You are not permitted to copy the SOFTWARE or any of the accompanying documentation.

COPYRIGHTS: All title and copyrights in and to the SOFTWARE (including but not limited to any images, photographs, animations, video, audio, music, text, and “applets” incorporated into the SOFTWARE), the accompanying printed materials, and any copies of the SOFTWARE are owned by PSP. The SOFTWARE is protected by copyright laws and international treaty provisions. Unauthorized reproduction or distribution of the SOFTWARE or documentation is subject to civil and criminal penalties.

DISCLAIMER OF WARRANTY: The SOFTWARE is provided “AS IS” and without warranty of any kind. The entire risk arising out of the use or performance of the SOFTWARE and documentation remains with user. To the maximum extent permitted by applicable law, PSP further disclaims all warranties, either express or implied, including, but not limited to, implied warranties of merchantability and fitness for a particular purpose, with regard to the SOFTWARE, and any accompanying hardware. To the maximum extent permitted by applicable law, in no event shall PSP be liable for any consequential, incidental, direct, indirect, special, punitive, or other damages whatsoever (including, without limitation, damages for loss of business profits, business interruption, loss of business information, or other pecuniary loss) arising out of this EULA or the use of or inability to use the SOFTWARE, even if PSP has been advised of the possibility of such damages.

MISCELLANEOUS: This EULA is governed by Polish law. Should you have any questions concerning this EULA, or if you wish to contact PSP for any reason, please write to:

PSPaudioware.com s.c.
Bugaj 12;
05-806 Komorów,
Poland.

Acknowledgements

Plug-in Design	Piotr Dmuchowski
Programming and Algorithms	Piotr Dmuchowski
Additional Algorithms and Programming Assistance	Hubert Pietrzykowski & Mateusz Woźniak
Graphics	Piotr Dmuchowski
Additional Graphics	Dariusz Ostojski & Mateusz Woźniak
Documentation	Orren Merton, Piotr Dmuchowski & Mike Metlay
Product Manager	Antoni Ożyński
Platform	Adam Taborowski
Installer	Piotr Dmuchowski

Beta Testing:

Joachim Krukowski, Chris Landon, Joerg Huettner, Hans Van Even, Mat Jarvis, Barry Wood, Thorsten Puttenat, Hiroaki Honshuku, Devon Brent

We would like to offer our very special thanks to Orren Merton for the user manual and to the creators of the very inspiring and exciting patches included with the PSP 608:

- Alan Brunch,
- Alberto Rizzo Schettino,
- Chris Landon,
- Hans Van Even,
- Jacob Heijer and Piet Verbruggen (from the “PB00-Binson” preset to the bank’s end), a library containing 100+ settings to support playing music like Hank B. Marvin and the Shadows,
- Joachim Krukowski,
- Joanna Stefanska,
- Joerg Huettner,
- Maciej Polański,
- Maja Szydłowska,
- Oleg Yershov,
- Rick Paul,
- Ryan Chan,
- Whyman Backer.

We would also like to thank all our beta testers for their bug testing, comments and opinions.

Finally, thanks to all our customers around the world for ideas and help in development of new plug-ins!

By using this software you agree to the terms of any license agreement accompanying it. “PSP”, the PSP logo, “PSP 608 MultiDelay” and “It’s the sound that counts!” are trademarks of PSPaudioware.com s.c.

All other trademarks are the property of their respective owners.

Table of Contents

End User License Agreement.....	2
Acknowledgements.....	3
Overview.....	5
Features At A Glance.....	5
PSP 608 MultiDelay Quick Start.....	6
The Global Controls.....	7
PSP 608 MULTIDELAY LOGO.....	7
POWER.....	7
MAIN.....	7
TAP PAD.....	8
REVERB.....	8
The Multidisplay LCD.....	10
MULTIDISPLAY.....	10
Level Meters.....	10
Info Display.....	11
Timing Mode Buttons.....	12
Note Quantize Setup.....	12
Master Tempo Setup.....	12
Delay Zoom Setup.....	13
TAP PARAMS.....	14
GRAPH MODE.....	15
MODULATION.....	16
The Tap Section.....	18
Delay Tap Signal Flow.....	18
Delay Tap Parameters.....	19
Linked DELAY Sliders in TIME vs. NOTE Mode.....	20
Parameter Knobs in Link Mode.....	20
Tap Feedback Controls.....	20
Tap Input Gain Knob.....	21
Tap Stereo Controls.....	21
The DELAY Slider.....	22
The FILTER Module.....	22
The Modulation Section.....	23
The DRIVE Section.....	24
The REVERB Controls.....	25
The Master Feedback Section.....	26
Master Feedback Mode LCD.....	26
MULTIDELAY Mode.....	27
MULTITAP Mode.....	28
MULTIFB Mode.....	29
Master Feedback Signal Controls.....	30
Master Feedback Level and Panorama Controls.....	30
Master Feedback Filter Section.....	30
Master Feedback Modulation Section.....	31
Master Feedback Drive Section.....	32
The PANIC button.....	32
PRESET HANDLING AND VIEW OPTIONS.....	33
Preset Browser.....	34
Copy / Paste.....	35
A/B System.....	35
Undo / Redo.....	35
GUI resizing.....	35
Config section.....	36
Minimum System Requirements.....	37
Processing.....	38
Limitations of the demo version.....	38
Support.....	39

Overview

Thank you for purchasing PSP 608 MultiDelay!

PSP 608 MultiDelay is perhaps the most fully featured delay plug-in available. We have striven to offer you a creative tool that is not only functional, but inspiring. Each tap has selectable feedback, stereo image and position, delay time, multimode filter, modulation, drive/tape saturation, and reverb. Moreover, the feedback and drive can be placed at the beginning or end of the signal chain for even more sound design options!

The modulation section offers both an LFO and envelope follower, and the tape saturation algorithm is taken from our renowned mastering processors. And of course this can all be done at any bit depth and sample rate up to 24-bit/384 kHz, and be fully automated via your host software!

As you can imagine, with PSP 608 MultiDelay offering so much creative potential, it is a fairly deep plug-in. We have done our best to put all the controls and parameters that you need to access directly at your fingertips, while still giving you an intuitive and user-friendly dynamic GUI. If it seems complicated or even a little intimidating at first, don't worry: you'll get used to it fast – and this manual will help.

If we sound proud of this plug-in, it's because we are! We're musicians, producers, engineers, and DJs ourselves. We just love using this plug-in, and we're sure you will too!

Features At A Glance

- Up to 8 seconds of delay time per channel
- Continuous control over the delay time in milliseconds and/or chosen note quantization
- Three operation modes: MULTIDELAY, in which each tap has its own feedback buffer; MULTITAP, in which the Master Feedback operates on one (user selectable) tap; and MULTIFB, where turning off a tap leaves its feedback buffer signal active
- Each tap includes independent adjustment of gain, stereo field width and balance, delay time, filtering, modulation, saturation simulation, and reverberation
- Each tap can choose between multiple biquadratic filter types, including Low Pass, Band Pass, High Pass, Peak, and four Shelf filters
- Modulation section (LFO and envelope follower) offer adjustable modulation depth of ± 3 octaves, and can also be used to control filter cutoff
- Tape saturation simulation with adjustable gain, based on the algorithm used in our mastering processors
- Filtering module in feedback includes LP/BP/HP filter (either State Variable Filter or Biquad) with adjustable cutoff and resonance
- Vintage reverberation module for faithful simulation of spring and plate reverbs
- Support for sample rates up to 384 kHz
- Host automation of all processing parameters

PSP 608 MultiDelay Quick Start

If you are so excited to start playing with PSP 608 MultiDelay you can't read through the manual first, here are some quick steps to get you going:

1. Instantiate PSP 608 MultiDelay into an insert slot in your host DAW.
2. In the PSP 608 MultiDelay **MAIN** section, make sure the Power button is lit (ON).
3. Start playback on your host DAW.
4. Make sure you're getting a good **INPUT** signal into PSP 608 MultiDelay
5. In the **INPUT** section, click the LED number 1 to turn on the first tap.
6. Adjust Tap 1's **DELAY** slider until you hear the delay length you want.
7. In the **INPUT** section, adjust Tap 1's feedback **AMT** (amount) until you hear the delay tap trail out the way you want it to.
8. In the PSP 608 MultiDelay **MAIN** section, adjust the **MIX** and **OUTPUT** knobs until you have the right delay level and blend with your audio.
9. Repeat this process for as many of the other taps as desired.

As you can see, getting PSP 608 MultiDelay working isn't difficult at all. But these steps, while enough to get you started, don't reveal the true power and creative potential of this plug-in. For that, keep reading the rest of this manual!

Remember: the manual is your friend! We know this plug-in has a lot of options, but don't worry, you don't need to remember all of them at once. We designed the manual to be as comprehensive and user friendly as the plug-in itself, and the Table of Contents is very complete. Please use this as a reference whenever you need more detail. Also, look out for these shaded boxes for important notes, tips, and cautions.

The Global Controls

The top level of the PSP 608 MultiDelay interface is the Global section, shown below. This section consists of the main MULTIDISPLAY LCD and controls that affect PSP 608 MultiDelay as a whole.

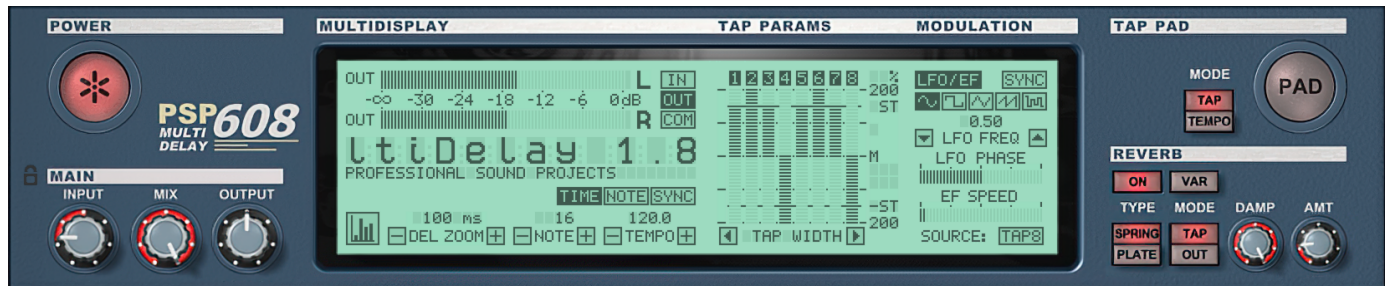

We'll start by going through the various control modules of the Global section, followed by exploring the MULTIDISPLAY LCD.

PSP 608 MULTIDELAY LOGO

If you hover your mouse over the PSP 608 MultiDelay logo, the Info Display will scroll the plug-in credits, version number, and your authorization information. Click the logo to show the back panel.

POWER

Perhaps the most obvious button in the Global section, the Power button turns PSP 608 MultiDelay on and off, effectively bypassing the plug-in.

MAIN

This section includes the main input/output controls.



INPUT: This control can either attenuate or boost the input signal. The range of the INPUT knob is -100dB to $+12\text{dB}$.

MIX: The MIX knob sets the proportion of Dry (unaffected) to Wet (processed) signal in the final output. As you adjust this knob, the MULTIDISPLAY will show you the exact percentage of Dry to Wet signal in your Master mix.

OUTPUT: This control attenuates or boosts the output of PSP 608 MultiDelay. The range of the OUTPUT knob is -100dB to $+12\text{dB}$.

PADLOCK: The padlock icon controls whether INPUT, MIX, and OUTPUT use values saved with a preset, or global values that remain the same during presets changes.

PADLOCK OPEN: Preset mode,
PADLOCK CLOSED: Global mode.

TAP PAD

Like all the best digital delay units, PSP 608 MultiDelay includes a Tap Tempo button.



The actual operation of the TAP PAD is pretty straightforward: When you click on the pad, the button lights up, and PSP 608 MultiDelay begins calculating the time between clicks.

TEMPO PAD MODES

The TEMPO PAD can operate in two different Modes:

- **TAP:** The time between button clicks sets the DELAY TIME for the selected Tap. The limit of the Tap Pad range is 8 seconds, just like the plug-in itself. If you keep clicking the TAP PAD after the 8 second limit is reached, then the TAP PAD clicks will set the DELAY TIME for the subsequent Tap. If you continually click the TAP PAD long past all the Tap's time limits, you will continually reset the DELAY TIME for all 8 of PSP 608's Taps, one after the other.
- **TEMPO:** The time between button clicks sets the TEMPO for the plug-in when not in host synchronization mode. The more times you click on the TAP PAD, the finer the adjustments of the Tempo will be.

NOTE: The TAP PAD can be assigned to a DAW control, such as a key, drum pad, or control surface button. This lets you click the TAP PAD with more precision than you might get from using the mouse, and allows you to quickly reset or adjust the tempo as you work.

REVERB

PSP 608 MultiDelay's reverb module offers high quality simulations of both spring and plate reverbs.



ON: When the ON button is lit, the reverb module is on. When the ON button is not lit, the Reverb module will not function, even if Taps are sending signal to the reverb module.

TYPE: PSP 608 MultiDelay includes simulations of two reverb types:

- **SPRING:** Clicking this button will select PSP 608 MultiDelay's Spring reverb algorithm. The earmarks of the spring reverb sound are its unique periodic reverb pattern and the fact that the reflection density does not increase with time.
- **PLATE:** This button selects the Plate reverb type. Plate reverbs are traditionally brighter than spring reverbs, and the reflection density increases over time.

MODE: PSP 608 MultiDelay reverb can operate in either TAP or OUTPUT mode.

- **TAP:** In TAP mode, the reverb is applied to each Tap that sends signal to the reverb module. In this mode, you can think of each Tap as having a send to an outboard reverb module. When the reverb is in TAP mode, any post-DSP feedback will include the reverb in the signal (see FEEDBACK below for more details).

- **OUT:** In OUTPUT mode, reverb is only applied to the final output of PSP 608 MultiDelay. In this mode, you can think of the outputs of the 608 being fed into a reverb module. When the reverb is in OUTPUT mode, the individual reverb sends of the Taps have no effect.

VAR: Introduced in version 1.7.0. The VARIation button switches between the PSP 608 MultiDelay “LEGACY” reverberation algorithms (available in the previous versions) and the new plate and spring modeling algorithms, called “REFINED”. The new Refined reverbs are engaged when VAR button is lit.

DAMP: This knob controls how quickly the reverb reflections *damp*, or diminish. This also effectively determines the reverb time—less damping results in a longer reverb, more damping results in a shorter reverb.

AMT: The AMT knob adjusts the proportion of dry to wet (reverberated) signal.

NOTE ABOUT AMT KNOB IN TAP MODE

When the Reverb module is in TAP mode, the final amount of wet signal for each Tap will be determined by both the AMT knob *and* the individual Tap’s reverb send (REV). For example, if a Tap sends 30% of its signal to the Reverb module and the AMT knob is set at 50%, the effective Wet level at PSP 608 MultiDelay’s output for that tap will be 15%.

In other words, if you are using the Reverb module in Tap mode, and you want each individual Tap’s reverb send (REV) to determine the final reverb output level of each tap, you’ll want to set the AMT knob to 100% Wet.

The Multidisplay LCD

The Multidisplay LCD is the most dynamic element of the PSP 608's GUI. It's "dynamic" in the sense that it is responsive to your mouseovers, and changes to reflect the current status of each tap and of the plug-in as a whole.

At first glance, it appears to be so crammed full of information that it might seem intimidating. But when you explore it more thoroughly, you'll see that it's very neatly organized and easy to follow.

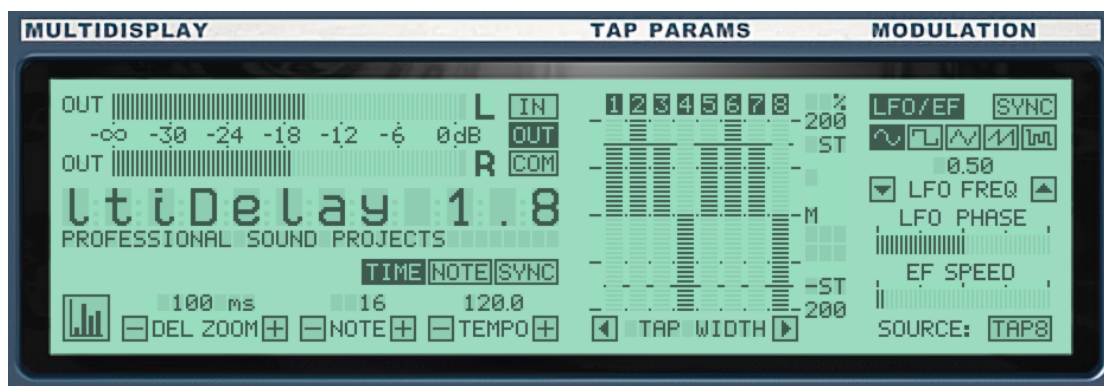

Notice that the Multidisplay LCD is divided into three parts: **MULTIDISPLAY**, **TAP PARAMS**, and **MODULATION**. These divisions correspond to the type of information that you will generally find in that particular segment of the LCD display. (This changes somewhat in GRAPH mode, as we'll see.) Let's take a tour through each part of the MULTIDISPLAY LCD, one section at a time, so you can get a better idea of what you're looking at.

MULTIDISPLAY

The MULTIDISPLAY section is so named because it consists of buttons, meters, and readouts for multiple functions and elements within the PSP 608 MultiDelay plug-in.

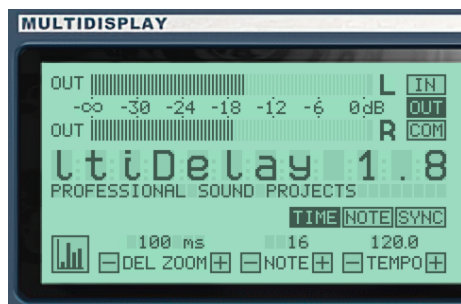

The MULTIDISPLAY section contains the following elements:

Level Meters

The PSP 608 MultiDelay level meters offer both peak indicators and three operation modes.

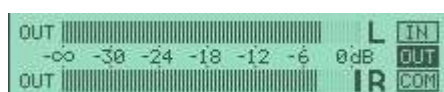

The Peak Indicator (the dark solid line by the "R" above) will stay lit for 5 seconds whenever the signal exceeds 0dB.

The meters can operate in **INPUT**, **OUTPUT**, or **COMPARATIVE** mode. You change the meter operation mode by clicking one of the three buttons to the right of the meter. These buttons are:

- **IN:** The meters operate in INPUT mode, showing you the input signal to the plug-in.
- **OUT:** The meters operate in OUTPUT mode, showing you the output signal from the plug-in.
- **COM:** In COMPARATIVE mode, the meters compare the input and output level to give you a composite of the two. The COMPARATIVE mode uses the channel with the highest level for its measurement.

Note: You can assign a DAW automation control to Meter Mode for easy switching as you work.

Info Display

The Info Display follows your mouse position to offer a dynamic readout of the currently selected parameter and its value.

For example, if you mouse over to the DELAY time of Tap 1, the Info Display shows:

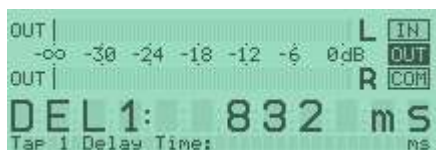

If you then move to the FILTER section of Tap 1, the Info Display changes to:



And finally, if you decide to adjust the overall MIX level, the Info Display reads:

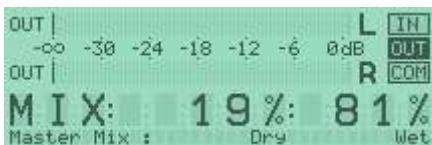

The Info Display consists of three parts:



Parameter: This is the actual parameter that you are currently editing or mousing over.

Parameter Value: This is the current value of the parameter. As you change this value, the display will change as well.

Parameter Label: This offers more information on the Parameter and Parameter Value displayed above.

Timing Mode Buttons

PSP 608 MultiDelay offers three different Timing Modes. Under these buttons are the specific parameters for the Note Quantize and Master Tempo.

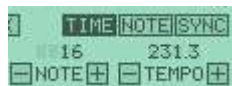

TIME: In TIME mode, PSP 608 MultiDelay’s delays operate in milliseconds, and the plug-in’s master tempo is determined by the tempo set in the TEMPO section below.

NOTE: In NOTE mode, PSP 608 MultiDelay’s timing is based on musical notes, and its delays operate in note denominations (8th note, 16th note, 16th note triplet, and so on). The master tempo for the duration of the notes is determined by the Master Tempo Setup tempo (see the following section).

SYNC: In SYNC mode, PSP 608 MultiDelay’s delays will also be quantized to notes, but the plug-in’s master tempo is determined by the host DAW application.

Note: For SYNC mode to work, the host application must be able to send tempo information to the PSP 608 MultiDelay!

Note Quantize Setup

Under the TIME button is the Note Quantize Setup section. This allows you to quantize the delays to a specific musical note value.

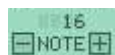

To adjust the note quantize value, you can either click the + or – buttons, or click the word “NOTE” and drag the mouse up or down to raise or lower the value.

Master Tempo Setup

Under the NOTE and SYNC buttons is the Master Tempo Setup section. Here you can set the master tempo for PSP 608 MultiDelay.

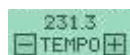

To adjust the master tempo value, you can either click the + or – buttons, or click the word “TEMPO” and drag the mouse up or down to raise or lower the value. In SYNC mode, the host application sets the master tempo.

Note: The Master Tempo Setup section is really only important in NOTE mode.

Delay Zoom Setup

The Delay Zoom Setup section.

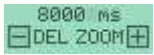

This section allows you to set the range of the delay slider in each Tap (and the X-Axis in GRAPH mode, which will be explained in the GRAPH MODE section). You can use this feature to:

- Limit the range of the Delay sliders in order to make very fine adjustments with your mouse or control surface.
- Limit the range of the Graph in GRAPH mode to see your delays in more detail.
- Return the range to full after previously limiting the range.

To adjust the delay zoom value, click the + or - buttons to raise or lower the value.

In NOTE mode, the delay zoom range is expressed in Bars and Beats instead of Milliseconds.

Graph Mode Display Switch

The button that looks like a bar graph is the Graph Mode Display Switch.



This button switches the Multidisplay LCD into GRAPH MODE, which we'll explain after the TAP PARAMS section (which, like the MULTIDISPLAY section, is replaced when GRAPH MODE is activated).

TAP PARAMS

The TAP PARAMS section lets you both view and edit Tap parameters in a bar graph style view, as shown below. The TAP PARAMS display not only lets you view parameters from your Taps in an intuitive and useful way, but also adjust those parameters right on the display, without needing to mouse down to the Tap itself!

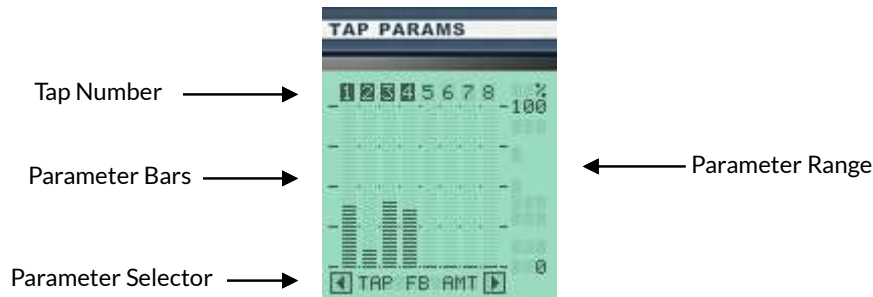

Activating Taps in the TAP PARAMS Display

As you can see, the top element of the graph is the Tap Number. Activated Taps are highlighted. If you click on a deactivated Tap, it will become active.

Choosing Which Parameter to Display in the TAP PARAMS Display

The Parameter Selector is under the TAP PARAMS graph. By clicking the right and left arrow buttons of the Parameter Selector, you can scroll through the parameters that can be displayed in the TAP PARAMS graph. You can choose between any Tap parameter with a dial control to view in the TAP PARAMS display.

You will notice that the Y-Axis legend will change to reflect the range of the selected parameter. For example, if you have Tap Feedback Amount (TAP FB AMT) selected as shown in the screenshot above, the Y-Axis range will be from 0% to 100%. However, if you were to select Tap Width (TAP WIDTH) as shown in the screenshot below, the range would now be -200% to 200%, just like the range on the Tap Width knob itself.

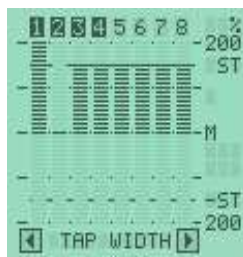

Adjusting Parameters in the TAP PARAMS Graph

Perhaps the most useful feature of the TAP PARAMS section is that not only does it offer a graphic representation a given parameter across all Taps, but you can adjust the parameter directly from the graph! Just click on the bar of the parameter you wish to adjust, and then drag the mouse up or down to raise or lower the value.

For fast editing across one or more Taps, just keep the mouse button down and drag across the graph. Each Tap that you drag across will be adjusted accordingly. Keep in mind, however, that dragging across Taps to adjust them will not activate any Tap that is not already active.

GRAPH MODE

By clicking the Graph Mode Display Button (described in the MULTIDISPLAY section), the MULTIDISPLAY and TAP PARAM displays will be replaced by the GRAPH MODE display. The MODULATION section of the display is not affected. As shown below, GRAPH MODE shows the relationship of one parameter from each Tap over time.

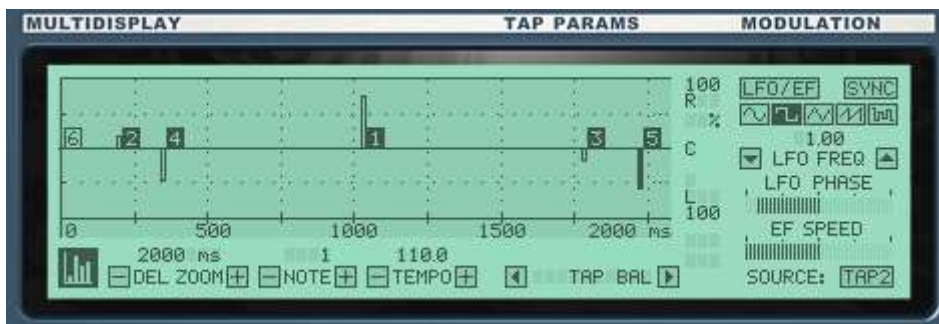

In GRAPH MODE, only the buttons below the graph are active. You cannot adjust the parameter or activate/deactivate Taps on the graph itself, but the graph will reflect all adjustments you make on the Taps themselves.

As with the TAP PARAMS display, if a Tap is active, its number will be highlighted in a dark square. If feedback has been turned on for a Tap (in other words, the FB button pressed, as explained later in the manual), the graph line will appear bright.

Note: Please refer to the Delay Zoom Setup, Note Quantize Setup, and Master Tempo Setup subsections above for information on adjusting those parameters.

Just Click the Graph Mode Display Button again to toggle back to MULTIDISPLAY mode.

Changing the Parameter Displayed on the Graph

Notice that the name of the parameter displayed on the graph appears between two arrows under the graph to the right of the Master Tempo Setup Section:

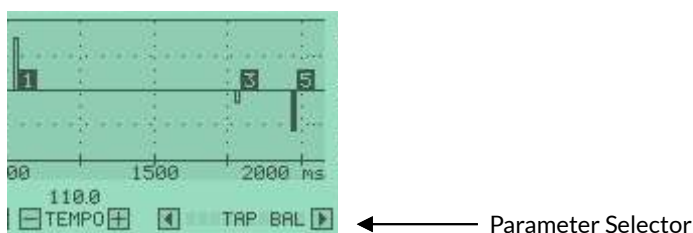

This is the Parameter Selector. To select a parameter to display on the graph, click either the right or left arrow to scroll through the available parameters. Like the TAP PARAMS display, all the parameters controlled by a dial are available to be shown on the graph.

Also like the TAP PARAMS display, you will notice that the Y-Axis range will change with the selected parameter. The graph's X-Axis, however, will always be time, modified only by the Delay Zoom Setup parameter.

MODULATION

PSP 608 MultiDelay features a powerful and flexible LFO and Envelope Follower, shown below.



The Modulation section does not offer separate LFO and Envelope Filter settings for each Tap; however, each Tap can access the Modulation section, and individually mix the proportion of LFO modulation and Envelope Follower modulation.

LFO/EF On/Off Button



Click the LFO/EF button to turn on the Modulation module. When engaged, the button will be darkened.

Host Note LFO Note Synchronization Button



The SYNC button syncs the LFO to the start of each Bar if the host application can send song position information.

IMPORTANT: The SYNC button only works when the LFO Rate is set to NOTE mode.

LFO Waveform Selector Buttons



These buttons allow you to select from between the five LFO waveform types available. The waveforms available are: sine wave, square wave, triangle wave, sawtooth wave, and a random waveform. The shape of the waveform determines the location and sharpness of the peaks in the oscillation cycle.

LFO Frequency Selector

Below the Waveform Selector Buttons is the LFO Frequency Selector.



You can select an LFO frequency between 0.1Hz and 15Hz. To adjust the LFO frequency, click the LFO FREQ label and drag the mouse up or down to raise or lower the value.

LFO Note Mode Buttons

To the right and left of the LFO FREQ label are the two buttons for placing the LFO rate into Note mode and determining the note value of the LFO rate. The left button determines the note numerator, the right button the note denominator.

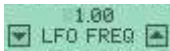

Numerator

Denominator

To first engage LFO Rate Note mode, click either the Numerator or Denominator button. Once the LFO Rate is in Note mode, its Info Display will show you the current Note Numerator and Denominator instead of the LFO Rate in Hz. The Parameter Label will indicate that you are in LFO Rate Note mode, and will also show the LFO Rate in Hz – which will be calculated by the plug-in, based on the length of the note in relation to the tempo of the song.

For example, let's say you want the LFO Rate to be a cycle that is three quarter notes in length. Here's what you would do:

1. Click on either the Numerator or Denominator button to activate LFO Note Mode. The Info Display will show the current numerator and denominator of the note.
2. Click on the Numerator button until the numerator in the Info Display changes to 3.
3. Click on the Denominator button until the denominator in the Info Display changes to 4.

That's it! Your Info Display should match the image below.



LFO Phase Slider



The LFO PHASE slider lets you set the phase offset between PSP 608 MultiDelay's two LFO signals. You can set the offset between -90 and +90 degrees.

Envelope Follower Speed Slider



The EF SPEED slider is actually an integrated control of the Envelope Follower's attack/release time. The reason we call it EF SPEED instead of EF ATTACK/RELEASE is that it changes the width of the time window for which the average absolute input signal value is calculated. The EF SPEED range is 1 ms to 1000 ms.

Envelope Follower Input Source Selector

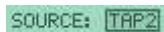

Click inside the Envelope Follower Input Source Selector in order to choose the signal that the Envelope Follower will use as its input source. You have 10 choices:

- IN: The Envelope Follower will use the PSP 608 MultiDelay INPUT signal as its input source.
- OUT: The Envelope Follower will use the PSP 608 MultiDelay OUTPUT signal as its input source.
- TAP (1-8): The Envelope Follower will use the output signal of one of the 8 Taps as its input source.

Note: When the Envelope Follower uses the output of a selected Tap, this will include all the DSP processing done to that Tap.

The Tap Section

The Tap Section is the heart of PSP 608 MultiDelay. This section contains controls for the plug-in's 8 delay taps, and follows on the GUI directly above the Master Feedback section:



While you can access many parameters in the TAP PARAM section of the MULTIDISPLAY LCD, the Tap Section is where all the controls for each tap are laid out sequentially.

Delay Tap Signal Flow

Each Delay Tap has the same control setup, shown here:



This very closely follows the path that the INPUT signal follows through the Tap, shown in the signal flow diagram below:

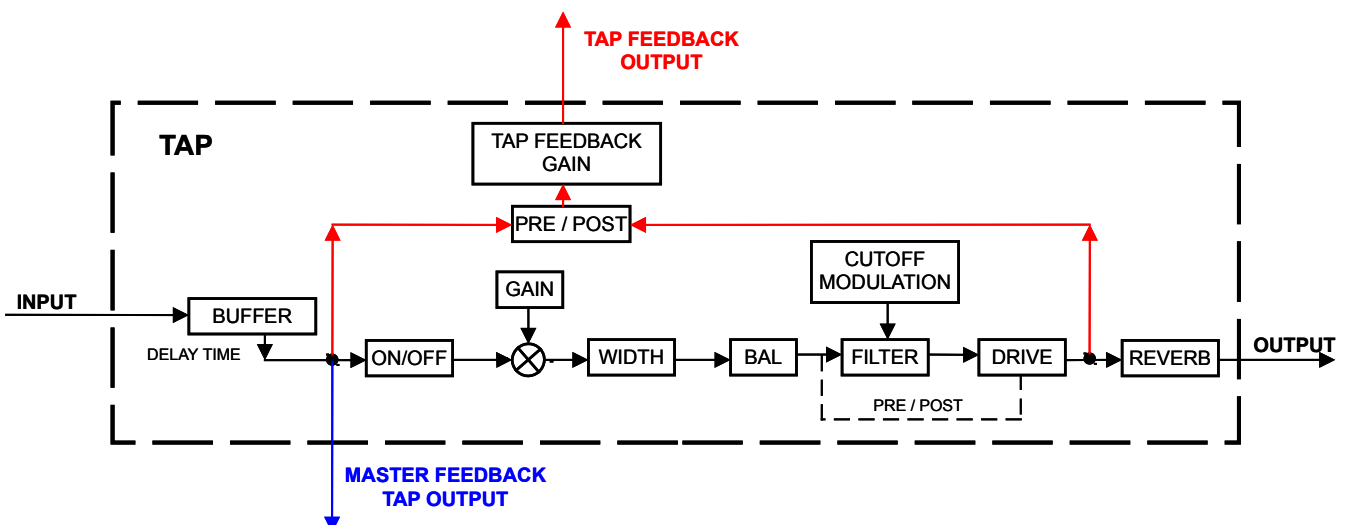

As you can see, you can modify the signal path of the input signal by choosing PRE or POST Feedback or Drive, but otherwise the input signal will flow through each process in the same sequence from right to left through the Tap parameters.

Delay Tap Parameters

As mentioned above, each Delay Tap has the same parameters. Each parameter will be described below.



Tap Input Section

The first section in each Tap is the Tap Input section.



The Tap Input section consists of three buttons:

ON: The Tap number is the ON button for each Tap. When the Tap is ON, the number will be illuminated red, and the Tap Number will be darkened in the TAP PARAM and TAP GRAPH displays. You can also use right-click this button to solo a Tap:

Tap Solo

If you have more than one Tap active, sometimes you'll want to audition one single Tap for individual assessment or adjustment. PSP 608 MultiDelay offers a Tap Solo function for just these occasions. To solo a specific Tap, simply right-click on its ON button, and the other active Taps will toggle off. To re-engage the other Taps, simply right-click the ON button of the soloed Tap a second time.

Note: If you have right-clicked a Tap to solo it, but then click the ON button of another Tap, the Tap Solo buffer will be cleared, and you will not be able to re-toggle the Taps that were turned off by the Tap Solo.

FB: In MULTIDELAY mode, the FB button turns on feedback for that Tap. In MULTITAP mode, the Feedback (FB) button determines which Tap is sent to the Master Feedback module. (See Feedback Modes in the Master Feedback subsection for more information on the two Feedback Modes.)

LNK: The Link (LNK) button allows you to link the parameter controls of two or more Taps together. In other words, if the LNK button is active on two or more Taps, if you adjust a control on one Tap, the control will also be adjusted in the other linked Taps.



Linked DELAY Sliders in TIME vs. NOTE Mode

When adjusting the DELAY slider in TIME mode, the Taps have a *relative* link. What this means is that the *ratio* of the time difference between the linked Taps is maintained. For example, let's say that one of a set of linked Taps has a 100ms delay, while another linked Tap has a 50ms delay. While the actual time difference between the two Taps is 50ms, the ratio is approximately 2:1. If you then shorten the first Tap to 50ms, the second Tap will be shortened to 25ms – in other words, the exact difference in time between the two taps is *not* maintained, but the *relative* length of time, based on the ratio of the delays of the two Taps, *is* maintained.

Note that if one Tap is at 0ms and you shorten the DELAY time of a linked Tap, or if one Tap is at 8000ms and you lengthen the DELAY time of a linked Tap, this relative link will be broken.

If you are in TIME mode, and you want each linked slider to maintain their exact distance from each other, you can hold down the SHIFT key while adjusting the slider of a Tap. This will toggle the link to a proportional link. In this mode, the precise duration between the linked Taps is maintained. As with relative links, if one Tap is already at 0ms and you continue to shorten the DELAY time of a linked Tap, or if one Tap is at 8000ms and you continue to lengthen the DELAY time of a linked Tap, this proportional link will be broken.

When adjusting the DELAY slider in NOTE mode, the Taps have a *proportional* link. This means that the proportions of the note durations between each linked Tap to another will be maintained. As above, if one Tap is already at its shortest delay and you continue to shorten the DELAY time of a linked Tap, or if one Tap is at its longest delay and you continue to lengthen the DELAY time of a linked Tap, this proportional link will be broken.

If you want to adjust the DELAY slider of a Tap in Link Mode without adjusting the other linked DELAY sliders, the ALT key (OPTION on the Macintosh) can act as a sort of “clutch” or “quick toggle.” Just hold the ALT/OPTION key down while moving the DELAY slider of a linked Tap, and only that Tap will be affected.

Parameter Knobs in Link Mode

The parameter knobs are also linked when more than one Tap is in Link mode. Parameter knobs always have a *proportional* link with the parameter knobs of other Taps (see above for the explanation of proportional linking).

As with the DELAY slider, if you hold ALT/OPTION down when adjusting a parameter knob, only that knob will be adjusted.

If you hold the SHIFT key down while adjusting a parameter knob, the corresponding parameter in other linked Taps will jump to the same value as the adjusted parameter.

Tap Feedback Controls

The Feedback section of each Tap includes two controls: the AMT (amount) knob, and the POST button.



AMT: The feedback amount (AMT) knob allows you to adjust the amount of feedback for the Tap. In MULTIDELAY mode, the Info Display will show you a percentage representing the level of the feedback for that Tap.

In MULTITAP mode, you choose which Tap will be sent to the Master Feedback section (see MULTITAP Mode in the Master Feedback section of this manual). When in MULTITAP mode, the Info Display will show a percentage representing the level of the Tap that is being sent to the Master Feedback section. For example, if you turn the knob one-third up, the Info Display will show you that you are sending a level of 30% of the Tap level to the Master Feedback section.

Note: In MULTITAP mode, the AMT and Master Feedback GAIN knob interact with each other to determine the final feedback percentage. See the note in the MULTITAP Mode description in the Master Feedback section for further explanation.

POST: In MULTIDELAY mode, the POST button determines if the Tap will feed back before or after the processing section. When the button is lit (red), POST is engaged. If you want the subsequent feedback echoes from your Tap to have the same processing as the initial Tap, click the POST button. If you want only the first echo to go through the processing section, leave the POST button unchecked.

This button has no effect in MULTITAP mode.

Tap Input Gain Knob



The GAIN knob adjusts input signal gain. The range of the GAIN knob is -100dB to +12dB. You can use the GAIN control for fine adjustment to increase or decrease the level in order to get a strong signal into your Tap, but don't be afraid to use it creatively, too! You could use the GAIN knob to emphasize one Tap over another, to lower the gain of one Tap until it is almost a subliminal texture element rather than a main focus, and so on.

Tap Stereo Controls

Each Tap offers you two knobs controlling the Tap's stereo field and position: WIDTH and BAL.



WIDTH: This knob determines the width of the stereo field of the Tap. It is variable from -200% to +200%. Raise the stereo width to create a larger sense of space and openness, reduce the stereo width to create a smaller and narrower space. When you are using multiple Taps, you can utilize this to give different Taps different stereo fields, making each Tap even more distinct. By holding down the CONTROL/COMMAND key and clicking, you can access the three default positions of these knobs.

BAL: This knob adjusts the balance, or emphasis, between the left stereo image and right stereo image. This has the effect of changing the perceived location of the Tap in the stereo field.

Keep in mind that if you are instantiating this plug-in on a MONO audio track, the BAL knob will only have the effect of strengthening or weakening the signal, depending on how far you have adjusted the balance from the center position.

The DELAY Slider



The DELAY slider adjusts the delay time or the delay note, depending on the mode you are in. In TIME mode, the DELAY slider operates in milliseconds; in NOTE mode, it operates in the note division determined in the Note Quantize Setup (described in the MULTIDISPLAY section above).

Moving the slider to the right increases the delay time or note, while moving the slider to the left decreases the delay time or note.

The DELAY slider has a fairly long track, which means that you can make very fine adjustments to the delay time or note—especially if you use the Delay Zoom Setup (described in the MULTIDELAY section above) to zoom in on a finer resolution.

Clicking on one of the arrow buttons to the right and left of the DELAY slider allows you to increase or decrease the delay by one unit (either millisecond or note, depending on the mode). If you click-hold on an arrow button for three seconds, you will engage the slider's auto-increase or auto-decrease, in which the slider automatically moves by one unit at a time until you release the mouse button.

The FILTER Module

Each Tap in PSP 608 MultiDelay has its own FILTER section with eight filter types to choose from.



The FILTER module controls are described below:

ON: Click this button to activate or deactivate the filter module for that Tap.

TYPE: This is where you can choose the specific biquadratic filter type that will process that Tap. The specific filter types are:

- **LP** (Low Pass)—Frequencies above the cutoff frequency will be attenuated
- **BP** (Band Pass)—Frequencies outside the bandwidth will be attenuated
- **HP** (High Pass)—Frequencies below the cutoff frequency will be attenuated
- **PEAK**—this peaking filter acts as a single band equalizer around a resonant frequency
- **LSHB**—This is a low pass shelving filter with resonance around the center frequency
- **LSHC**—This low pass shelving filter has a resonance around the cutoff frequency (see the graph below).
- **HSHB**—This is a high pass shelving filter with resonance around the center frequency
- **HSHC**—This is a high pass shelving filter with resonance around the cutoff frequency

Graph of the low pass shelving filter with resonance around the cutoff point

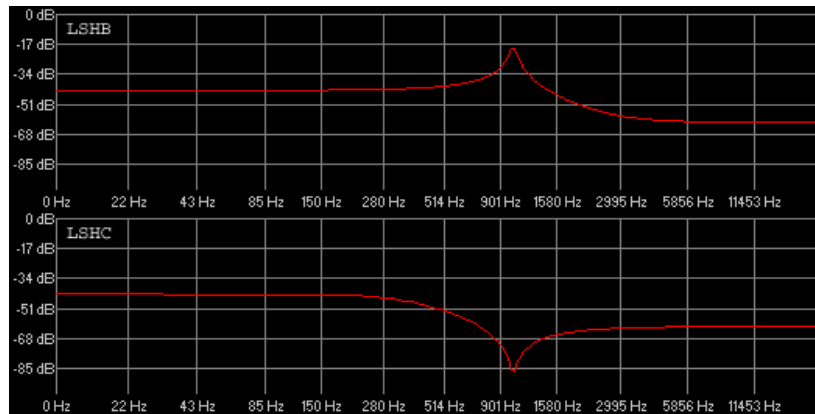

FREQ: This is the cutoff frequency for the filter. If the LFO/EF (modulation section) is ON, and you are using the LFO to modulate the cutoff frequency (meaning LFO FREQ is greater than 0), the value set with this knob will be the center frequency around which the LFO will oscillate the cutoff frequency.

RESO: This knob adjusts the resonance of the filter. It has a 24dB range. Turning the knob clockwise increases the resonance around the cutoff frequency chosen with the FREQ knob, while turning the knobs counterclockwise reduces the resonance.

For the BP and PEAK filters, which are not resonant filters, this knob controls the filter bandwidth instead. Turning the knob clockwise will increase the bandwidth, and turning the knob counterclockwise will reduce the bandwidth.

GAIN: You can adjust the gain of the Shelving, BP and PEAK filters with this knob. The GAIN control does not affect the High Pass or Low Pass filters.

The Modulation Section

Each Tap can send its signal to the Modulation module. Three parameters determine how each Tap will be modulated.



These parameters are:

SRC: The Source (SRC) button lets you adjust the mix of the two modulation sources (the LFO and Envelope Follower). At the center point, the Tap will be modulated equally by both the LFO and the Envelope Follower. Turning the knob to the left raises the level of LFO modulation and decreases the amount of Envelope Follower modulation. Turning the knob to the right raises the level of Envelope Follower modulation, and decreases the amount of LFO modulation.

The Info Display shows you exactly what percentage of your Tap is going to each modulation source. For example, if you turn the knob up about 30% from full left, the Info Display will show:

```
TAP 2: 70%: 30%
Tap 2 Mod Source : LFO EF
```

This lets you know that the LFO will be responsible for 70% of the modulation of your signal, and the Envelope Follower only 30%.

PHS: The Phase (PHS) button switches between the two LFO signals. You can use this button in conjunction with the LFO PHASE slider of the Modulation module to offset each signal up to 180

degrees. This way, you can effectively switch between two different LFO signals by clicking this button!

DEPTH: This knob controls the depth of the modulation. Lower depth settings will result in a subtle modulation, while higher depth settings can result in deep modulations and wild special effects, depending upon your settings in the Modulation section of the MULTIDISPLAY LCD.

The DRIVE Section



Each Tap has its own DRIVE module. This isn't just any old DRIVE module, by the way; the PSP 608 MultiDelay DRIVE is based on the tape saturation algorithms from PSP Audioware's highly acclaimed professional mastering plug-ins. Give it a try—you'll like it!

The DRIVE module is comprised of three controls:

ON: As with the Tap itself, the FILTER, and the REVERB modules, the asterisk-labeled button is the ON button. Toggle this button to activate and deactivate the DRIVE module.

PRE: This button determines if the DRIVE module will process the Tap before or after the FILTER module. When the PRE button is lit (red), the DRIVE process will be placed before the FILTER in the signal chain.

DRV: The Drive (DRV) knob controls the depth of the DRIVE. Don't think of this as a gain or drive knob on a distortion effect; since the PSP 608 MultiDelay's DRIVE is a tape saturation function, think of the DRV parameter as determining how hard the Tap hits the "virtual tape." Since hitting tape harder results in both more saturation and more compression, as you increase the DRV, you increase the saturation and compression while at the same time reducing the overall level of the Tap. The graph below should give you an idea of how increasing the saturation depth will affect the level of your signal.

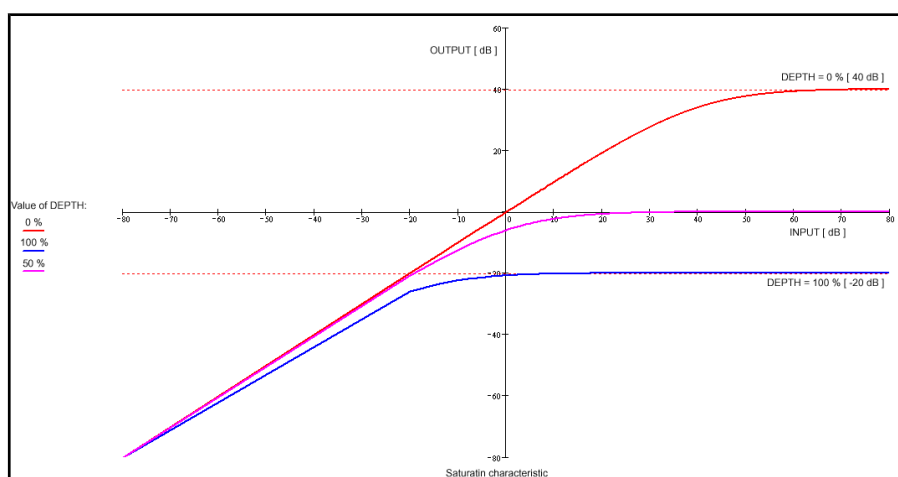

The REVERB Controls



Each Tap has its own send to the REVERB module described in the section on The Global Controls. The REVERB module must be in TAP mode for the REVERB controls in the Taps to have any affect.

There are only two controls here:

ON: When lit (red), the REVERB send is ON.

REV: This is the Reverb send knob. Turn this knob up to send more of the Tap to the REVERB module. Be sure to read the note in the REVERB section regarding how the AMT and REV knobs interact.

The Master Feedback Section

The Master Feedback Section is beneath the 8 Taps on the GUI. It looks similar to the rest of the Tap Section, but is clearly different.



The Master Feedback section serves three functions in PSP 608 MultiDelay:

1. It gives you parameters to adjust the gain, panorama, and processing independently from the Taps themselves
2. It lets you choose between the MULTIDELAY, MULTIFB, and MULTITAP modes
3. It houses the PANIC button

Let's go through the various components of the Master Feedback section, including the signal flow of the various Master Feedback Modes.

Master Feedback Mode LCD

To the right of the ON button is the LCD display in which you select between the three Master Feedback Modes: MULTIDELAY, MULTITAP and MULTIFB.



You can toggle the MODE by clicking in the small box with the name of the Mode. A description of each Mode follows.

MULTIDELAY Mode

In this Mode, each individual Tap gets its own feedback buffer, meaning that each Tap can have its own feedback, independent of the other Taps. See the signal flow diagram below:

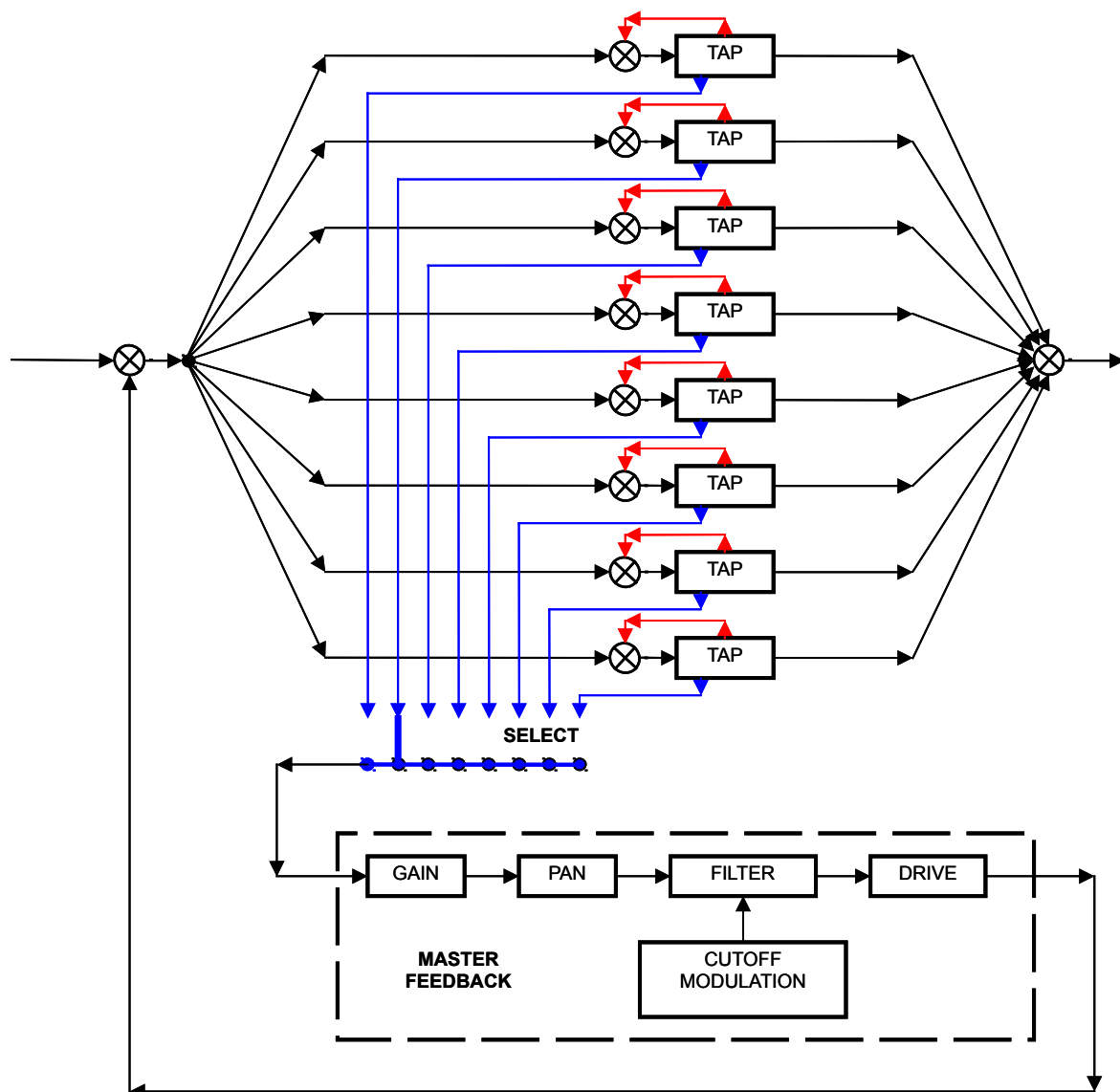

SOURCE: As you can see from the diagram above, while all Taps can send their signal into the Master Feedback section, only one specified Tap serves as the source for the processing modules. Click the TAP number under the SOURCE label to select the Tap that will be the Source for the Master Feedback processing.

MULTITAP Mode

The second Master Feedback Mode is MULTITAP mode.

In this mode, there is only one single feedback buffer for all the Taps, and the FB button selects which Tap will be sent to the Master Feedback section. The diagram below illustrates MULTITAP mode signal flow:

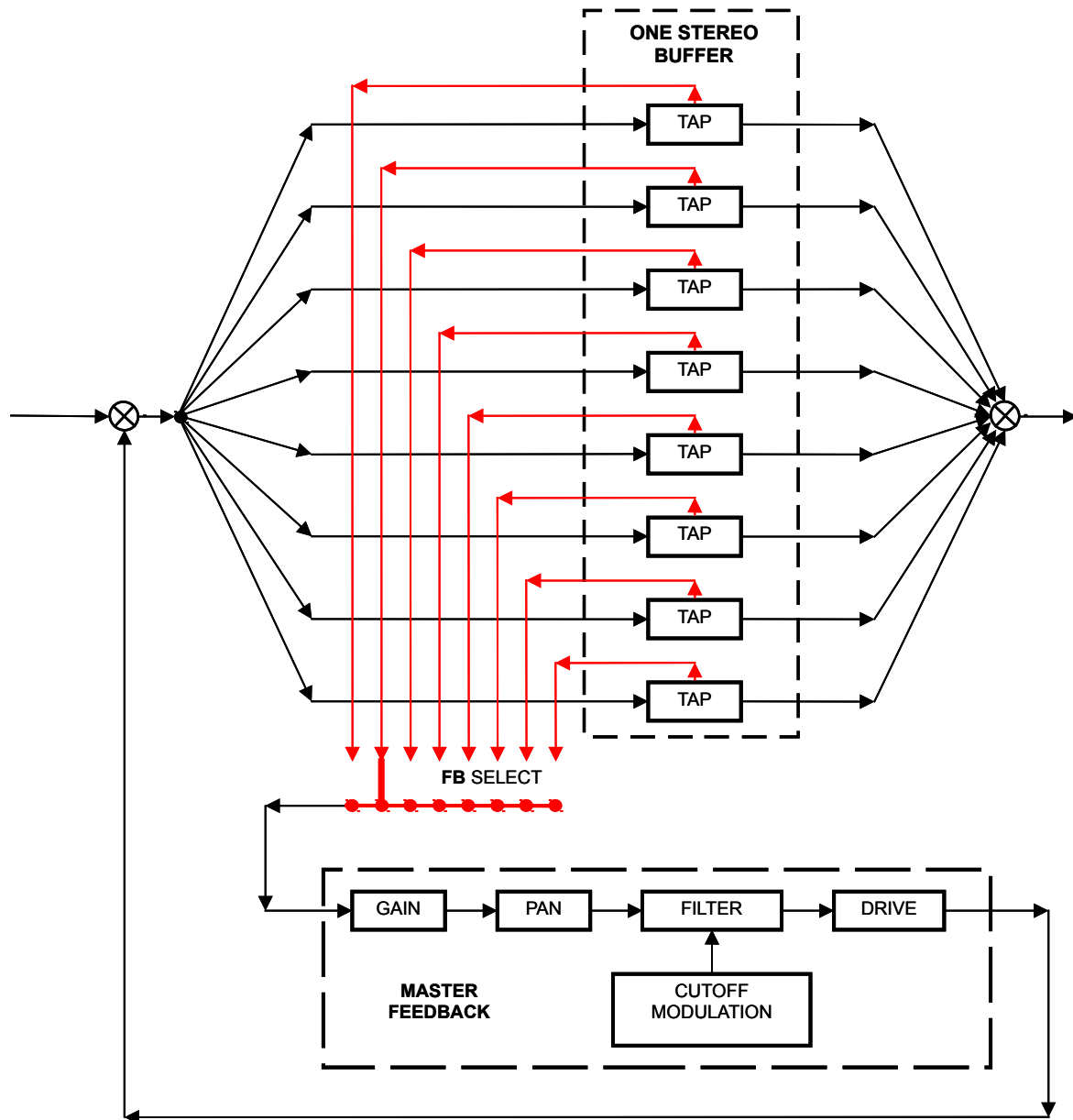

In MULTITAP mode, the **SOURCE** parameter in the Master Feedback Mode LCD isn't active, since you're only sending one Tap to the Master Feedback buffer anyway. In MULTITAP mode, you select which Tap will be the source for the Master Feedback section by clicking its FB button, as described above in the Delay Tap Parameters subsection.

MULTIFB Mode

The last Master Feedback Mode is MULTIFB mode. This mode is similar to MULTITAP, but all controls and the feedback buffer of the Master Feedback are inactive. In this mode, switching off a tap does not switch off the signal. This function allows feedback to remain on the tap after switching it off. Additionally, movement of the delay sliders doesn't damp the sound of the tap.

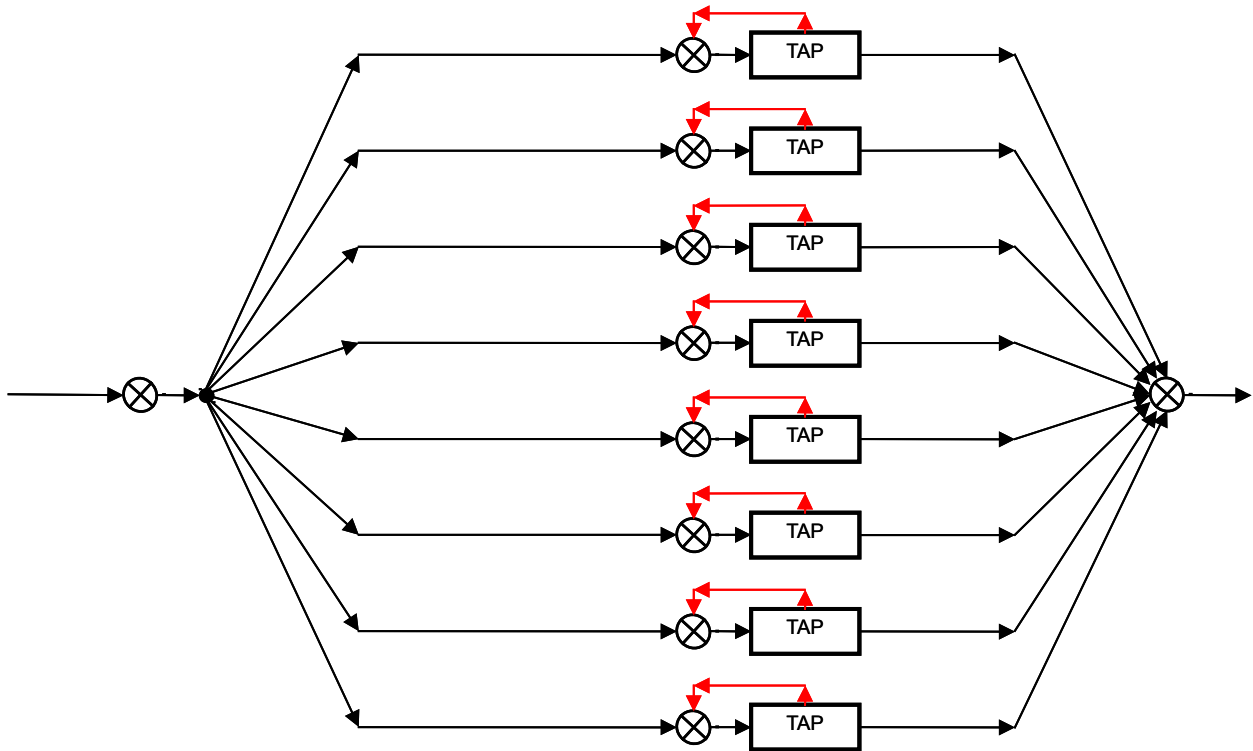

Master Feedback Signal Controls

ON: The first control on the left is of course the ON button. When this is lit (red) the Master Feedback section is turned on.

Master Feedback Level and Panorama Controls



There are four controls that adjust the Master Feedback level and panorama:

GAIN: This controls the level of the feedback section. The Info Display tells you the percentage of the feedback level relative to the Tap signal. In other words, if the Master Feedback GAIN is 30%, that means the feedback will be at 30% of the level of the Tap signal.

NOTE ABOUT THE GAIN KNOB IN MULTITAP MODE

When you select MULTITAP mode, the final level of feedback in the output will be determined by both the GAIN knob and the chosen Tap's AMT knob. For example, if the chosen Tap sends 30% of its signal to the Master Feedback section and the GAIN knob is set at 50%, the effective feedback level at PSP 608 MultiDelay's output will be 15%. In other words, if you are using MULTITAP mode, and you want the chosen Tap's feedback amount knob (AMT) to determine the final feedback output level, you'll want to set the GAIN knob to 100%. If you want the Master Feedback GAIN knob to control the final feedback output level, you'll want to set the AMT knob of the Tap being sent to the Master Feedback section to 100%.

PAN L and PAN R: These two knobs give you completely independent panorama control over both left and right signals. In other words, you can pan both signals differently, so that the left signal is coming from the middle of the left stereo field, but the right signal is coming from full right. Use these knobs in conjunction with the BAL knob in each tap for some very creative stereo panning options!

Master Feedback Filter Section

Just like the individual Taps, the Master Feedback section has its own FILTER section.



The controls are as follows:

ON: This button turns on the FILTER section. When the button is lit (red) it is on.

TYPE: The Master Feedback FILTER section offers some biquadratic filter types that are familiar to us from the Tap section, as well as some State Variable Filters not present in the individual Taps. State Variable Filters are quadruple oversampled for the best possible sound quality.

The available Master Feedback module filter types are:

- **BQHP (Biquadratic High Pass)**—This filter is the same as the Tap Section's HP filter

- **SVHP** (State Variable High Pass)—This is a high pass filter that adds a slight saturation
- **BQLP** (Biquadratic Low Pass)—This filter is the same as the Tap Section’s LP filter
- **SVLP** (State Variable Low Pass)—this is a low pass filter that adds a slight saturation
- **BQBP** (Biquadratic Band Pass)—This filter is the same as the Tap Section’s BP filter
- **SVBP** (State Variable Band Pass)—This is a band pass filter that adds a slight saturation

FREQ: This is the cutoff frequency for the filter. If the LFO/EF (modulation section) is ON, and you are using the LFO to modulate the cutoff frequency (meaning LFO FREQ is greater than 0), the value set with this knob will be the center frequency around which the LFO will oscillate the cutoff frequency.

RESO: This knob adjusts the resonance of the filter. It has a 12dB range. Turning the knob clockwise increases the resonance around the cutoff frequency chosen with the FREQ knob, while turning the knobs counterclockwise reduces the resonance.

For the BP filters, which are not resonant filters, this knob controls the filter bandwidth instead. Turning the knob clockwise will increase the bandwidth, and turning the knob counterclockwise will reduce the bandwidth.

WARNING! When you turn on the filter in both an individual Tap and the Master Feedback section, the sharp resonances created and you can very easily overload your sound! PSP 608 MultiDelay has some built-in protections against overloading your speakers—any signal 24dB over the original signal will be reduced to exactly 24dB over the original signal (this overload protection affects both the Tap and Master Feedback output). Always start with low feedback and resonance values when using multiple filters and increase them gradually until you achieve the desired effect. When experimenting, it’s a good idea to lower the plug-in master output level as well.

Master Feedback Modulation Section



The Master Feedback section also can access the LFO/EF module. It cannot select between the two LFO signals, however. Its controls are as follows:

SRC: Like the SRC knob in each Tap, the Source (SRC) button lets you adjust the mix of the two modulation sources (the LFO and the Envelope Follower). At the center point, the Master Feedback will be modulated equally by both the LFO and the Envelope Follower. Turning the knob to the left raises the level of LFO modulation and decreases the amount of Envelope Follower modulation. Turning the knob to the right raises the level of Envelope Follower modulation, and decreases the amount of LFO modulation.

DEPTH: This knob controls the depth of the modulation. Lower depth settings will result in a subtle modulation, while higher depth settings can result in deep modulations and wild special effects, depending upon your settings in the MODULATION section of the MULTIDISPLAY LCD.

Master Feedback Drive Section



The Master Feedback section has its own DRIVE parameters as well. These function similarly to the individual Tap DRIVE parameters.

ON: Toggle this button to activate and deactivate the Master Feedback DRIVE module.

DRV: The Drive (DRV) knob controls the depth of the DRIVE. As explained in the Tap DRIVE section, think of this parameter as determining how hard the Tap hits the “virtual tape.” Since hitting tape harder results in both more saturation and more compression, as you increase the DRV, you increase the saturation and compression while at the same time reducing the overall level of the Tap.

The PANIC button



Inevitably, when dealing with delays and feedback, in your sound design and creativity you will very likely create an infinite loop, or overly loud or sharp repeating tone, that you'll want to stop immediately. Enter the PANIC button! This button instantly sets the Master Feedback GAIN and all AMT values to 0, and turns off any activated FB buttons. This will instantly stop any nasty loops.

NOTE: The PANIC button can be controlled via host software automation. You can assign it to a button or other control, so it can be activated instantly without your having to find your mouse and click on the button in the GUI.

PRESET HANDLING AND VIEW OPTIONS

Every PSP plug-in comes with a large library of factory presets. You can use them as a starting point for experimenting with your own sounds, examine them to understand how the various features work, or keep them handy for when a track or mix needs a quick and high-quality way to create an effect or fix a problem.

To access the preset library, just click on the Preset Bar along the top of the plug-in window. If you're familiar with other PSPaudioware plug-ins, you'll find that this one works exactly the same way.

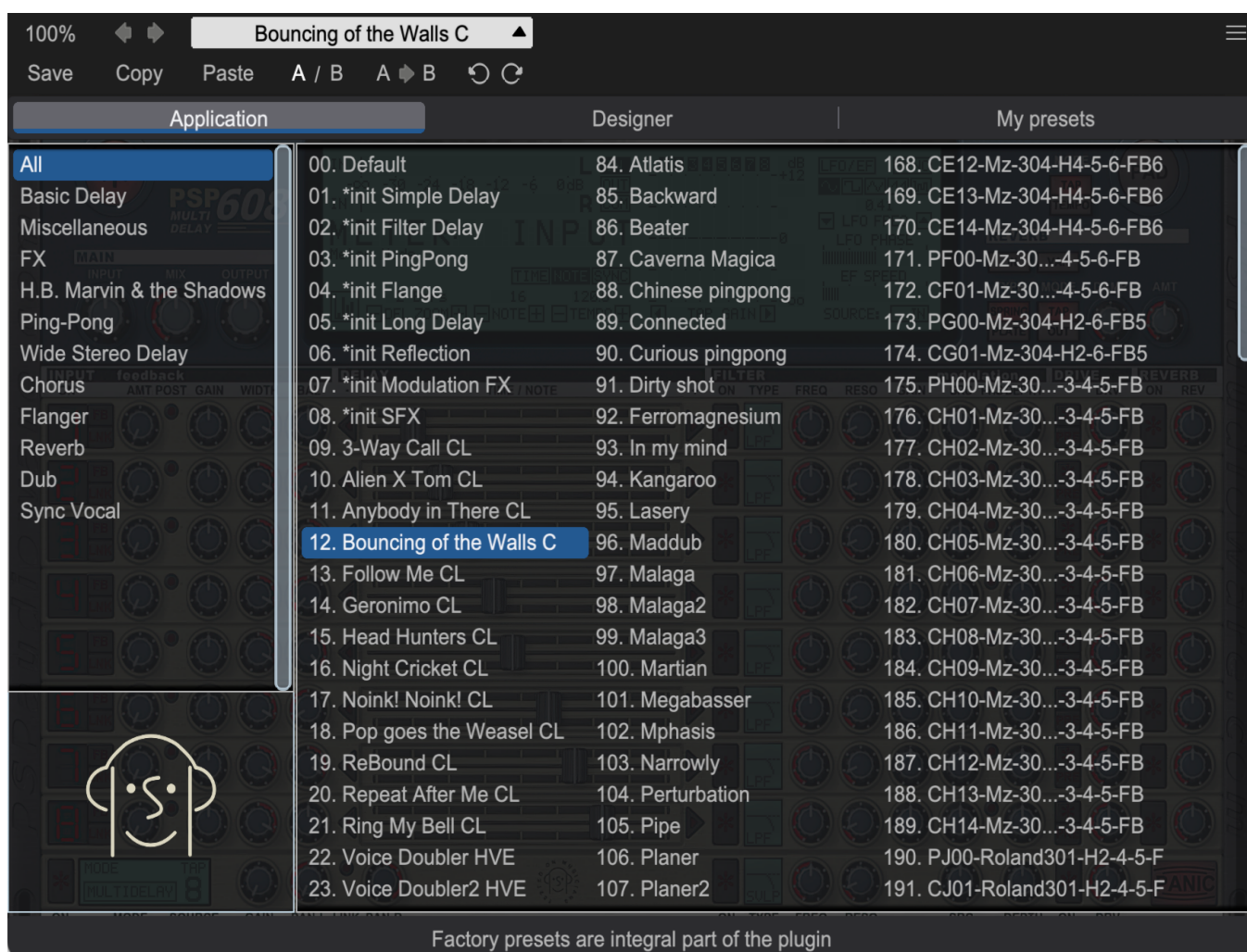

Preset Browser

PSP 608 MultiDelay features a comprehensive preset management and browser system. To access the preset browser, simply click on the preset name window at the top of the plug-in (which displays 'Default' when the plug-in loads).

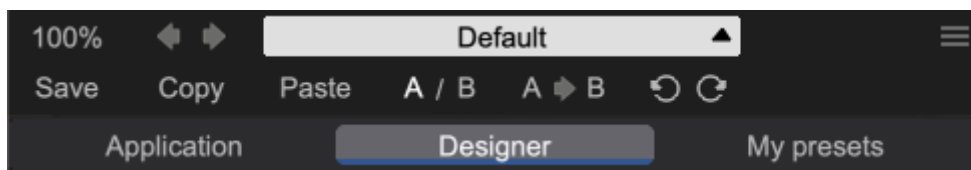

The new preset manager has three main categories which can be accessed via the tabs at the top of the preset browser: **Application**, **Designer**, and **My presets**.

Application – shows all factory presets, sorted by application or type of effect. These can be selected from a list on the left side of the preset browser.

Designer – shows all factory presets, sorted by designer. A photo of the designer is displayed for each of their presets. Click on the photo to open the designer's website.

My presets – shows only the presets you have created and saved, or downloaded and added to your custom presets for PSP 608 MultiDelay.

NOTE: The Factory presets are built into PSP 608 MultiDelay. While you can't edit them directly, you can make adjustments to them, and then save the result as a user preset.

To add categories to the preset list, you can create new subfolders in the preset directory.

For Windows users, this is located at:

C:\Users\Username\Documents\PSPaudioware.com\User Presets\PSP 608 MultiDelay

For Mac users, this is located at:

~/Documents/PSPaudioware.com/User Presets/PSP 608 MultiDelay

NOTE: You can find the exact file location by clicking on the **Show File in Finder** button at the bottom of the preset browser window.

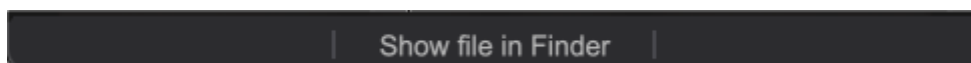

To select a preset, simply click a preset name in the right window. On the first click, the preset will be temporarily loaded so that you can audition it while still in the preset browser. To confirm the preset choice and get back to the main user interface, double-click the preset name again.

Copy / Paste

A dark rectangular button with the text 'Copy' and 'Paste' in white, separated by a small gap.

The **Copy/Paste** feature is useful for when you're running two or more instances of PSP 608 MultiDelay and you want them to have identical settings.

Of course, you can always open a new instance and load the same preset as your first instance has, but this only works if your first instance hasn't been tweaked at all since the preset was loaded. To share your tweaks between instances, use **Copy** and **Paste**.

To use this feature, simply click the **Copy** button, open a new instance of PSP 608 MultiDelay where it's needed, and click the Paste button to load the first instance's settings.

This feature can be particularly useful for processing similar instruments or sounds, when only a few minor tweaks are needed for each instance.

A/B System

A dark rectangular button with the text 'A / B' and 'A → B' in white, separated by a small gap.

The **A/B system** lets you quickly audition changes to your settings. You can compare how different tweaks work in a track or mix, or even audition two different presets on the fly.

The **A/B Button** allows you to quickly switch between the current plug-in settings (**A**) and a previous group of settings that you've previously stored (**B**).

The **A>B Button** copies the **A** settings over to the **B** slot. This lets you temporarily 'bookmark' your current settings, make more tweaks, and then compare the new tweaks with your 'bookmarked' settings using the **A/B Button**.

Undo / Redo

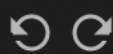

The **Undo/Redo** feature can be extremely important when designing presets! We all know the frustration when we make one too many edits and ruin a previously great sound. With the **Undo** and **Redo** buttons (the counterclockwise and clockwise arrows as shown above), you can step backward and forward through your edit actions until you're back where you wanted to be.

These buttons will let you undo a preset selection, returning you to your previous preset with all settings as they were when you stopped editing it.

GUI resizing

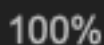
A dark rectangular button with the text '100%' in white.

The percentage at the top left shows the current user interface size. Click on it to reveal a dropdown menu of size choices, or hover your mouse on it and scroll up and down to change the size quickly. Double-click to reset it to the default size (100%).

You can also resize the plug-in interface by click- dragging the right bottom corner of the plug-in to any size you like.

Config section



Click the icon with three parallel lines in the top right corner to open the **CONFIG** menu. You will find controls to open the manual, hide or show mouse-hover tool tips (Hints), check your current plugin version with build number and show back panel

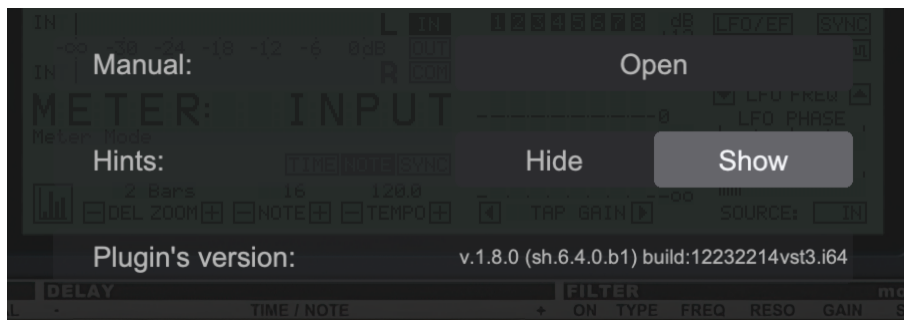

The 608 MultiDelay back panel.

Minimum System Requirements

PC

VST3

- Windows 7 – Windows 11
- 64-bit VST3 compatible application

VST

- Windows 7 – Windows 11
- 64-bit VST compatible application

AAX

- Windows 7 – Windows 11
- 64-bit Pro Tools 11, 12 or Pro Tools HD 11, 12 or Pro Tools Ultimate

All DAWs

- The latest iLok License Manager application installed (iLok USB license key not required)

Mac (both Intel and Apple Silicon processors are supported)

AudioUnit

- macOS 10.12 – macOS 13 Ventura
- 64-bit AudioUnit compatible host application

VST

- macOS 10.12 – macOS 13 Ventura
- 64-bit VST compatible host application

VST3

- macOS 10.12 – macOS 13 Ventura
- 64-bit VST3 compatible host application

AAX

- macOS 10.12 – macOS 13 Ventura
- 64-bit Pro Tools 11, 12 or Pro Tools HD 11, 12 or Pro Tools Ultimate

All DAWs

- Up to date iLok License Manager application installed (iLok USB license key not required)

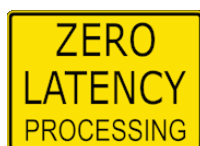

VST and VST3 are trademarks and software of Steinberg Media Technologies GmbH. AAX and Pro Tools are trademarks or registered trademarks of Avid Technology, Inc. AudioUnit, OS X, macOS, and Apple Silicon are trademarks of Apple Inc.

Processing

- PSP 608 MD supports 32 floating point audio streams.
- PSP 608 MD supports sample rates up to 384 kHz.

Limitations of the demo version

We offer a 30-day evaluation period without any audio interruptions or control limitations. To get access to the plug-in and your unique authorization details, simply login to your account at our [user area](#).

Enjoy !
PSP team

Support

If you have any questions about any of our plug-ins, please visit our website:

www.PSPAudioware.com

Where you can find the latest product information, free software updates, online support forum and answers to the most frequently asked questions.

Problems with the installation, activation or authorisation?

Please watch our [troubleshooting video tutorials](#) on our YouTube channel.

You can also contact us by e-mail: support@PSPAudioware.com.

We will gladly answer all of your questions. As a rule we respond within 24 hours.

PSPAudioware.com s.c.
Bugaj 12
05-806 Komorów
Poland.
ph. +48 601 96 31 73
www.PSPAudioware.com
contact@PSPAudioware.com

PSPaudioware.com s.c.
Bugaj 12
05-806 Komorów
Poland