

PANASONIC RAMSA WZ-AD96M OPERATING INSTRUCTIONS MANUAL



Table of Contents

[Contents](#)

[Overview](#)

[Features](#)

[Getting Started](#)

[Major controls and their functions](#)

[Front panel](#)

[Front panel \(shift mode\)](#)

[Rear panel](#)

[Quick start](#)

Signal Flow
Adjustment and Setting
DIP Switch Setting
Precise level adjustment for AD 96
Ref Level Setting
Word Length selection
TX mode selection
AES/EBU Output
Wordclock selection
Dual AEs Output Card
Peak Detection
AD Converter Calibration
Resume and clear the stored data
Memory Clear
Self Diagnosis
Key Lock
Internal setting & options
Wordclock-out setting
Wordclock block diagram
Options
Pin Assignment
Recommended Cable
TDIF Output Card
DB25 Y Cable
Mounting in the rack
Connecting the system
Connecting with the DA7 Digital Mixer
Connecting with the ADAT & BRC
Connecting with TDRS

Connecting with Pro Tools

Technical Specifications

Standard accessories

Optional accessories

Level diagram

Block diagram

Dimensions

High Sampling Digital Format

AES/EBU Outputs on the rear panel

Dual AES/EBU Output Card

ADAT output on the rear panel

Sub-code in AES/EBU Output

Other ManualsLib Projects

Panasonic

AD Converter / AD Converter & Mic Pre-Amp Operating Instructions

Model No. WZ-AD96 / WZ-AD96M

RAMSA

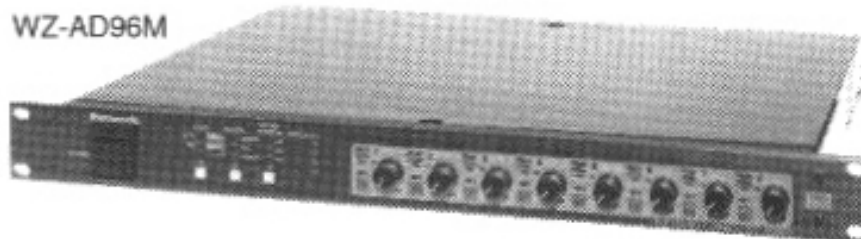
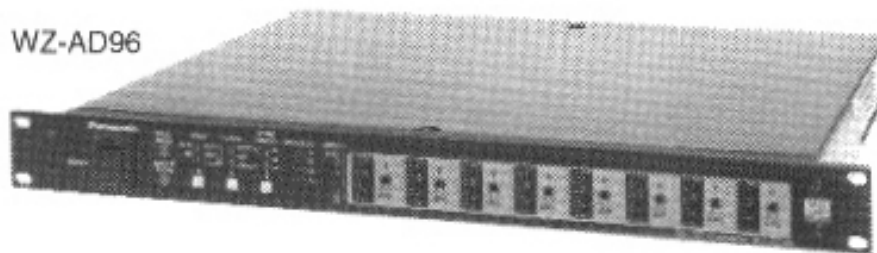

Before attempting to connect or operate this product,
please read these instructions carefully and save this manual for future use.

NOTE: This equipment has been tested and found to comply with the limits for a Class A digital device, pursuant to Part 15 of the FCC Rules. These limits are designed to provide reasonable protection against harmful interference when the equipment is operated in a commercial environment. This equipment generates, uses, and can radiate radio frequency energy and, if not installed and used in accordance with the instruction manual, may cause harmful interference to radio communications.

Operation of this equipment in a residential area is likely to cause harmful interference in which case the user will be required to correct the interference at his own expense.

FCC Caution: To assure continued compliance, (example - use only shielded interface cables when connecting to computer or peripheral devices). Any changes or modifications not expressly approved by the party responsible for compliance could void the user's authority to operate this equipment.

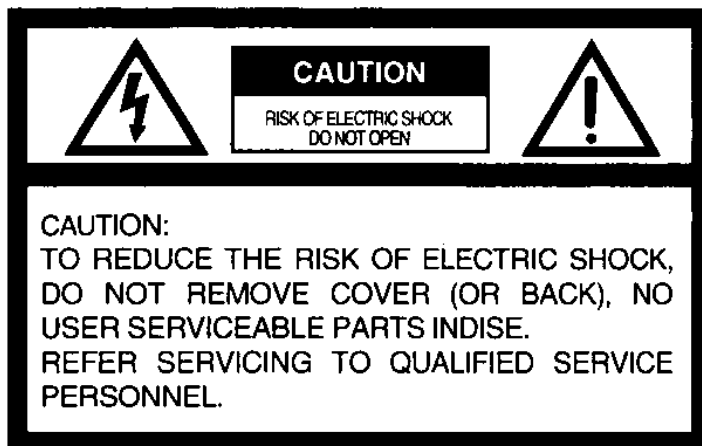

SA 1965

The lightning flash with arrowhead symbol, within an equilateral triangle, is intended to alert the user to the presence of uninsulated "dangerous voltage" within the product's enclosure that may be of sufficient magnitude to constitute a risk of electric shock to persons.



SA 1966

The exclamation point within an equilateral triangle is intended to alert the user to the presence of important operating and maintenance (servicing) instructions in the literature accompanying the appliance.

WARNING:

To reduce the risk of fire or electric shock, do not expose this appliance to rain or moisture.

The product name, RAMSA AD Converter is the property of Matsushita Communication Industrial Co., Ltd.. All other product names in this manual are the property of their respective holders.

Part number for this manual: YWA8QA5356AN

Caution:

Before attempting to connect or operate this product, please read the label on the bottom.

The serial number of this product may be found on the bottom of the unit.

You should note the serial number of this unit in the space provided and retain this book as a permanent record of your purchase to aid identification in the event of theft.

Model No. _____

Serial No. _____

CONTENTS

Regulatory Statements	2
1. Introduction	
Technical Support	7
Overview	8
Features	9
2. Getting Started	12
Major Controls and Their Functions	12
Front Panel (Normal Mode)	13
Front Panel (Shift Mode)	15
Rear Panel	16
Quick Start	19
Signal Flow	20
3. Adjustment & Setting	21
DIP Switch Setting	21
Precise Level Adjustment for AD96	22
Level Adjustment for AD96M	23
REF Level Setting	23
Word Length Selection	23
Tx Mode Selection	24
Wordclock Selection	24
Peak Detection	25
AD Converter Calibration	25
Resume & Clear the Stored Data	25
Self Diagnosis	26
Key Lock	26
4. Internal Setting & Options	27
Wordclock-Out Setting	28
Dual AES/ 8 Channel Output Card WZ-AESAD	29
TDIF Output Card WZ-TDIAD	30
DB 25 Y Cable	31
Mounting in the Rack	31

5. Connecting the System 32

- Connecting with the DA7 Digital Mixer 32
- Connecting with the ADAT & BRC 34
- Connecting with the TDRS 36
- Connecting with the Pro Tools 38

6 Technical Specifications 41

- General 41
- Analog Inputs 41
- Digital In & Out 41
- Standard Accessories 42
- Optional Accessories 42
- Level Diagram 43
- Block Diagram 44
- Dimensions 45

7. Appendix

- High Sampling Digital Format 46

PANASONIC TECHNICAL SUPPORT

(In the USA)

If you need to contact Technical Support for this or
any other Pro Audio product,
please call 323 436-3620 Monday through Friday
from 9am to 5pm Pacific time.

For other Panasonic Broadcast products,
please call 800-524-1448 Monday through Friday
9am to 5pm Eastern time.

Panasonic Broadcast & Television Systems Company
Professional Audio Division
3330 Cahuenga Boulevard
Los Angeles CA, 90068
Telephone: 323-436-3500

OVERVIEW

The WZ-AD96 and 96M AD Converters create a new world to digital recording, authoring and editing. The AD Converter eases analog materials to interface with various digital systems such as DVD multi-track authoring, PC-based DAW and MDM recording, and the input expansion in a digital mixer system, with flexible hookup.

It accepts an 8-channel analog input and finally supplies digital audio data in the Dual-Wire or Single-Wire format based on the AES3 Hi-Sampling standard to meet your system requirements. Beside an ADAT output as the standard, the TDIF output and Dual AES output cards are available as an option.

Pnasonic engineers have pursued what the real sound quality is and what makes high fidelity sound for years. All technologies we have learned are condensed in the 1-U compact body; custom LSI, circuit designs and layouts, component selections and so forth.

FEATURES

High Accuracy, high fidelity 8 channel/24 bit/96 kHz ADC

- Delta-Sigma system, 128-time Over-Sampling AD Converter is adopted. Wide dynamic range of 118 dB is achieved.
- Delay time among channels and units is negligible small.
- The solid capacitor used in the reference circuit is a key to stable conversion that is stable to long time use and high frequencies.
- Simplified Pre-Amplifier with Balanced In and Out
- Analog dynamic range of 126 dB (AD96) /120 dB (AD96M) is achieved thanks to fewer stages of low distortion amplifier.
- A discrete transistor circuit realizes low noise, E.I.N. of 128 dBu.
- Crosstalk of 114 dB is accomplished by optimum layout and taking both advantages of discrete parts and SMD.
- Carefully selected components; low-leakage transformer, hi-precision metalized resistors, customized capacitors and even one screw; contribute sound fidelity.

o

High bit, high sampling interface

- Compatible to MTRs and HDR in Dual-Wire AES mode, and to T.c electronics and other major processor units in Single-Wire Hi-Speed mode.
- ADAT Interface, 24 bit/48 kHz/8 channel or 24 bit/96 kHz/4 channel, easy interface with HDR and DAW.
- TDIF Interface, 24 bit/96 kHz/4 channel, easy interface with 24 bit TDRS to build a 4-track Hi-speed/Hi-Sampling recording system.
- Sync to external Wordclock ranging from 44.1 -6% up to 96 +6%.
- Reference level adjustable from among -14, -16, -18 and -20 dBFS by DIP switch.
- Wordclock output can be set to follow either the sampling frequency or AES output signal .

Low noise power supply and separate grounding system

- Discrete power circuit contributes to low impedance and low noise.
- Unchangeable idea of low impedance and separate layout is applied to grounding.
- Thick PCB pattern for power and ground, and large capacitors in each channel assure channel separation.
- Special made screws (patented) assure continuity of ground level, beside the GND terminal provided on the rear panel.

Precise Meters

- 0.05 dB accuracy digital meters, 10 point (AD96) and 3 point of Signal/Reference/Peak (AD96M), Zoom and Adjust mode provided to AD96.
- Peak detection adjustable for either use of a peak meter or clip meter.
- Reference level selected by the DIP switch to meet the connected device's.

Low power consumption

- Digital circuits are condensed in a small packed custom LSI with a 3.3 V operation voltage. This reduces power dissipation greatly and also interference between digital and analog.
- Power consumption as an 8-channel unit; 18 W (AD96)/19 W (AD96M); is comparable or even less to a 2-channel unit.
- Well considered temperature distribution not to affect on the AD converter.

Customizing

- DIP switch on the rear panel enables custom settings beside major operation and monitoring set on the front panel.
- Key lock function protects your customized settings from mis-operation and mischief.
- Dither is added to reduce significant distortion in audio output when 16 or 20 bit is selected.

GETTING STARTED

WZ-AD96
Front Panel

WZ-AD96M
Front Panel

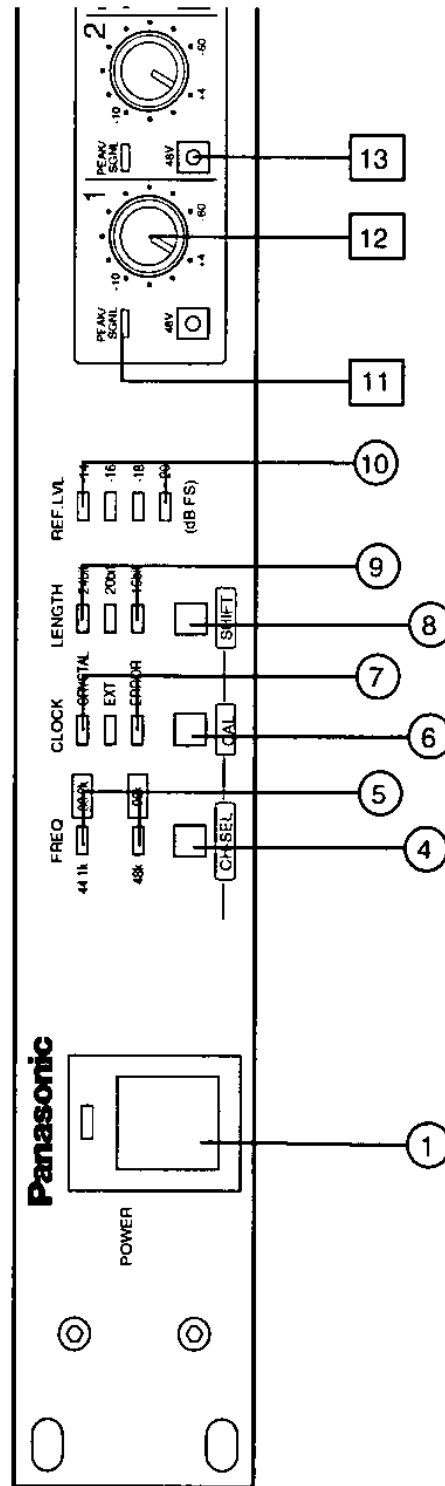
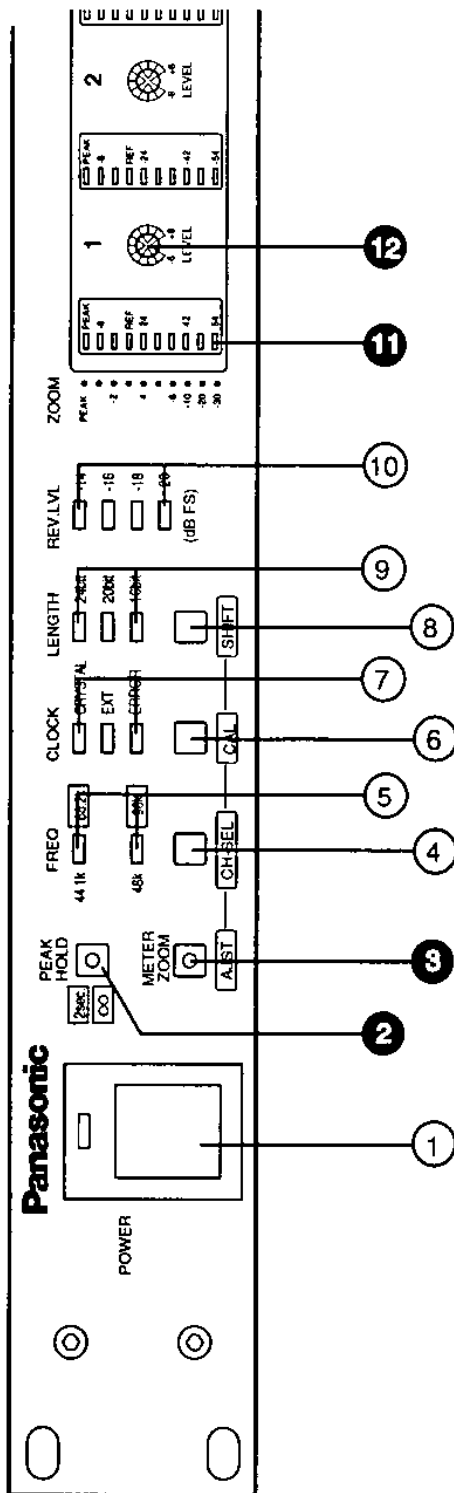

MAJOR CONTROLS AND THEIR FUNCTIONS

Buttons silk-printed half gray on the panel, here marked with < > brackets are assigned double operation modes: normal mode and shift mode. Indicators also have deferent function according to the operation modes. During the <Shift Mode> all three Word Length Indicators light to identify the operation mode. The <Shift Mode> operations are described after the normal mode operations.

FRONT PANEL (NORMAL MODE)

① Power Switch and Power Indicator [POWER]

Turns on or off the power. The indicator lights while the power is on.

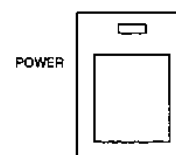

② Peak Hold LED Button [PEAK HOLD] AD96 only

Peak hold time changes each time the button is pressed as follows.

0 second (LED: OFF) → 2 seconds (LED: Green)
 → infinity(LED: Red) → 0 second (LED: OFF)

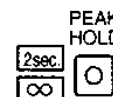

③ Meter Mode Selection LED Button [METER ZOOM] AD96 only

Meter mode toggles between the normal display and zoomed display each time the button is pressed.

Normal (LED: OFF) → Zoom (LED: Green)
 → Normal (LED: OFF)



④ Frequency Selection Button [FREQ]

When CLOCK is set to CRYSTAL the frequency is selected as follows every time the button is pressed. The respective indicator lights. 44.1k → 48k → 88.2k → 96k → 44.1k

When CLOCK is set to EXT and the unit follows 48k or 96k, the frequency is selected as follows every time the button is pressed. The respective indicator lights. 48k → 96k → 48k

When CLOCK is set to EXT and the unit follows 44.1k or 88.2k, the frequency is selected as follows every time the button is pressed. The respective indicator lights. 44.1k → 88.2k → 44.1k

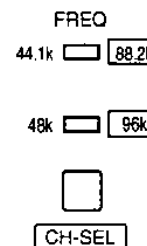

⑤ Frequency Selection Indicator [FREQ] [44.1k 48k 88.2k 96k]

The upper LED lights when 44.1 kHz (Green) or 88.2 kHz (Red) is selected. The lower LED lights when 48 kHz (Green) or 96 kHz (Red) is selected.

⑥ **Clock Source Selection Button [CLOCK]**

This button toggles the clock source selection either external or internal. If EXT is selected, this unit synchronizes to the wordclock signal supplied to the rear panel. The respective indicator lights.

- CLOCK
- CRYSTAL
 - EXT
 - ERROR

⑦ **Clock Source Selection Indicator [CRYSTAL EXT ERROR]**

Crystal: Lights in green when the unit operates with internal clock.

EXT: Lights in green when the unit synchronizes to the external clock.

Error: Lights in red when an unlock or no input is detected in the EXT setting, or for changing duration of internal frequency.



⑧ **Word Length Button [LENGTH]**

For dither processing this button selects word length from among 24 bit, 20 bit or 16 bit, and the respective indicator lights.

- LENGTH
- 24bit
 - 20bit
 - 16bit

⑨ **Word Length Indicator [24 20 16]**

Selected word length is displayed; 24-bit, 20-bit or 16-bit.



⑩ **Reference Level Indicator [REF LEVEL -20 -18 -16 -14]**

These indicators display the reference level (Unit: dBFS) set by the DIP switch on the rear panel.

- REF LVL
- 14
 - 16
 - 18
 - 20
- (dB FS)

⑪ **Level Meter [PEAK -6 REF -24 -42 -58, PEAK -2 -4 -8 -10 -20 -30]**

AD96 Only

A 10-point bar graph meter is provided for each channel in the meter section. The meters display levels in the normal or zoom mode set by the METER MODE LED button. The normal scale is put right side the each meter while the zoom scale is placed at the left side adjacent to the meter section.

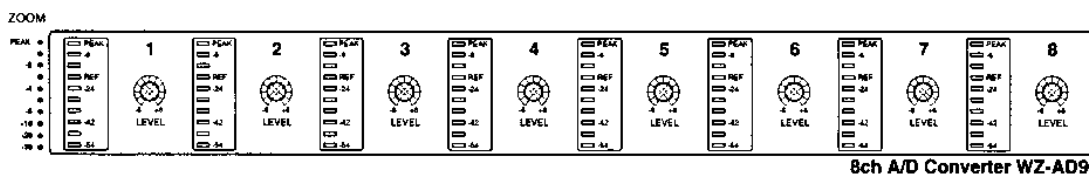

In the normal mode the right side scale is referred.

PEAK, -6, (-12), REF, -24, (-30, -36), -42, (-48), -54

In the zoom mode the left side scale is referred.

PEAK, (-1), -2, (-3), -4, (-5), -6, -10, -20, -30

⑫ **Input Level Trimmer [LEVEL] AD96 Only**

Use a screw driver to adjust the level.

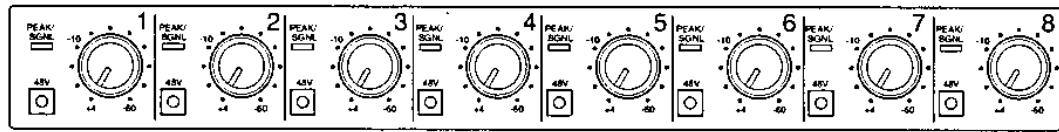

8ch A/D Converter & Mic Pre AMP WZ-AD96M

11 Level Indicator [PEAK/SIGNAL] AD96M only

Signal levels are indicated as follows. Peak detection level is set by the DIP switch on the rear panel.



- Red:** PEAK ≤ Level
- Amber:** REF ≤ Level ≤ PEAK
- Green:** -38 dBFS ≤ Level ≤ REF
- Off:** Level ≤ -38 dBFS

12 Input Level Trimmer [+4 -10 -60] AD96M only

Rotate the trimmer clockwise to boost or counter-clockwise to reduce the gain.

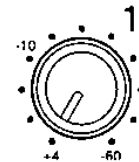

13 Phantom LED Button [48V] AD96M only

Phantom power, 48 V is switched on or off. The LED lights while 48 V is supplied to the analog input connector.



Caution! Phantom button can cause noise.

- Down the volume control of the amplifier to protect the speakers from damage caused by switching noise before operating the phantom button.
- Do not operate the phantom button for 30 seconds right after turning on this unit to avoid switching noise.

FRONT PANEL (SHIFT MODE)

Shift mode operations are briefly described below. Pressing the Word Length <Shift> Button for 2 seconds or more will transfer the operation modes. During the shift mode all three Word Length <Shift Mode> Indicators light to identify the operation mode.

3 <Level Adjust> LED Button [AJST] AD96 Only

Precise level adjustment is available. See page 23 for details.

METER ZOOM



AJST

4 <Out Channel Selection> Button [CH-SEL]

This button selects output channels to the AES/EBU DIGITAL OUTPUT connectors, 1-4 or 5-8. The respective indicator lights.

Notes:

- Out channel selection is not available if 44.1 kHz or 48 kHz is selected for the reference source.
- When the DUAL AES/EBU card is installed in the unit, Out channel selection is also available. Selecting 5-8 will result in that contents of the channel 5-8 are supplied to both the output channel 1-4 and 5-8 of the card.

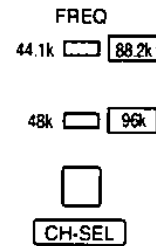

⑤ **< OUT Channel Selection > Indicator [44.1k 88.2k 48k 96k]**

The upper LED (44.1 kHz, 88.2 kHz) lights in green when a set of channel 1-4 is selected, or the lower LED (48 kHz, 96 kHz) lights when a set of channel 5-8 is selected.

⑥ **< Calibration > Button [CAL]**

Calibration to the clock synchronization is carried out manually by pressing this button. Digital outputs are mute during calibration.

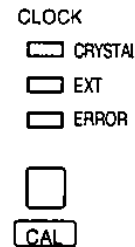

⑦ **< Calibration > Indicator [CRYSTAL EXT ERROR]**

Error indicator lights in red during calibration for about 1 second.

⑧ **< Shift Mode > Button [SHIFT]**

Press this button to enter or to quit the shift mode.

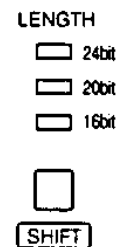

⑨ **< Shift Mode > Indicator [24bit 20bit 16bit]**

All three indicators light during the shift mode.

REAR PANEL

For AD96

① **Analog Input connector [1-8 ANALOG INPUT +4 dB 10kΩ (BAL)]**

These XLR connectors accept analog signals supplied by external devices. Input level is +4 dB for each channel. See the next page.

For AD96M

① **Analog Input connector [1-8 ANALOG INPUT -60 dB to +4 dB 10kΩ (BAL)]**

These XLR connectors accept analog signals supplied by external devices. Input level is adjustable with a trimmer from -60 dB to +4 dB for each channel. See the next page.

WZ-AD96
Rear Panel

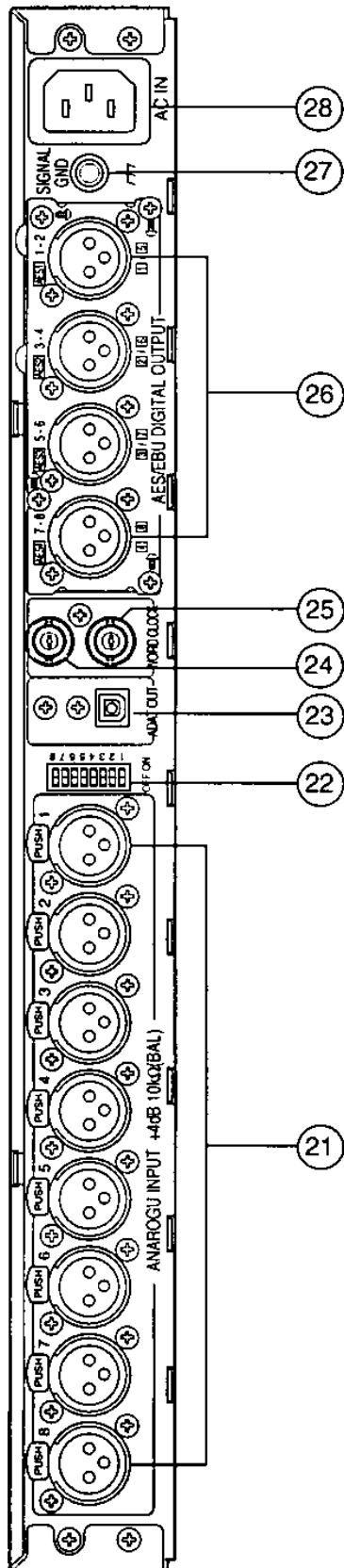

WZ-AD96M
Rear Panel

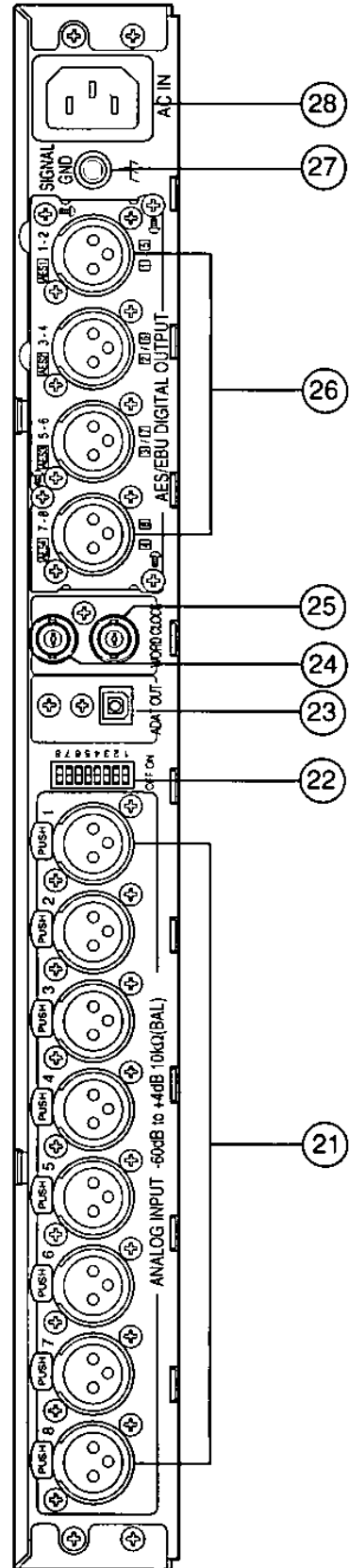

②② **DIP Switch [1 2 3 4 5 6 7 8 ON OFF]**

An 8-bit DIP switch is provided for settings . See page 21 for the setting.

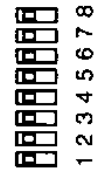

②③ **ADAT Output [ADAT OUT]**

This optical connector supplies digital outputs for ADAT.

OFF ON



②④ **Wordclock Input Connector [WORD CLOCK IN]**

This BNC accepts the wordclock supplied by an external device. To synchronize the internal clock to the wordclock in, select EXT by the CLOCK button, then select a frequency by the FREQ button.

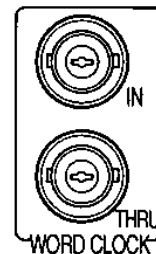

②⑤ **Wordclock Output Connector [WORD CLOCK THRU]**

This BNC supplies the wordclock looped through the WORD CLOCK IN.

②⑥ **Digital Output Connector [AES1 AES2 AES3 AES4 AES/EBU DIGITAL OUTPUT]**

These XLR connectors supply AES/EBU digital outputs. Output channels for Dual AES mode are selected from a set of 1, 2, 3 and 4, or 5, 6, 7 and 8 by the FREQ/CH SEL button in the shift mode operation.

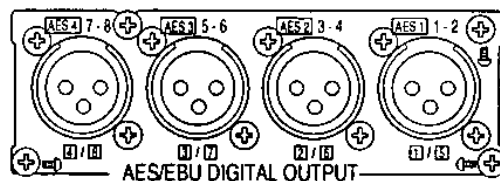

②⑦ **Grounding Terminal [SIGNAL GND]**

Connect with other devices' GND to level the mutual ground potential if required.

②⑧ **AC Inlet [AC IN]**

Connect the supplied power code.

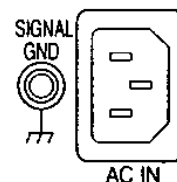

QUICK START

Join the 6 steps below before you start digital recording.

1. Connect an analog source to the input channel on the rear panel.
2. Connect ADAT output or AES/EBU outputs to an external digital device (for example a digital mixer, ADAT or DAT).
3. Turn on the AD converter, and confirm that POWER LED on the front panel lights.

To reset to DEFAULT settings, turn on the AD converter while holding down **FREQ** and **CLOCK** buttons at the same time.

4. Supply +4 dBu analog input, and adjust input trimmer so that REF LED lights (lights in amber for AD96M).

The default setting of REF level is -20 dBFS.

5. Repeat step 4, level adjustment for the rest channels.
6. Play the connected analog source. Then confirm that the level meter on the AD converter swings, at the same time that the connected digital device outputs analog signals or moves its meter.

See the next chapter, Adjustment and Setting, for REF level adjustment.

SIGNAL FLOW

The chart shows how the analog inputs are converted to digital outputs.

The supplied analog signals are adjusted in the level while going through the amplifier stage responding to the trimmer positions on the front panel.

The ADC transforms analog signal to digital data. The digitized audio data are fed to word length, REF level adjustment stages and then to meters. Word length is set on the front panel while the REF level is selected on the rear panel. Meter functions are controlled by buttons on the front panel and DIP switches on the rear panel.

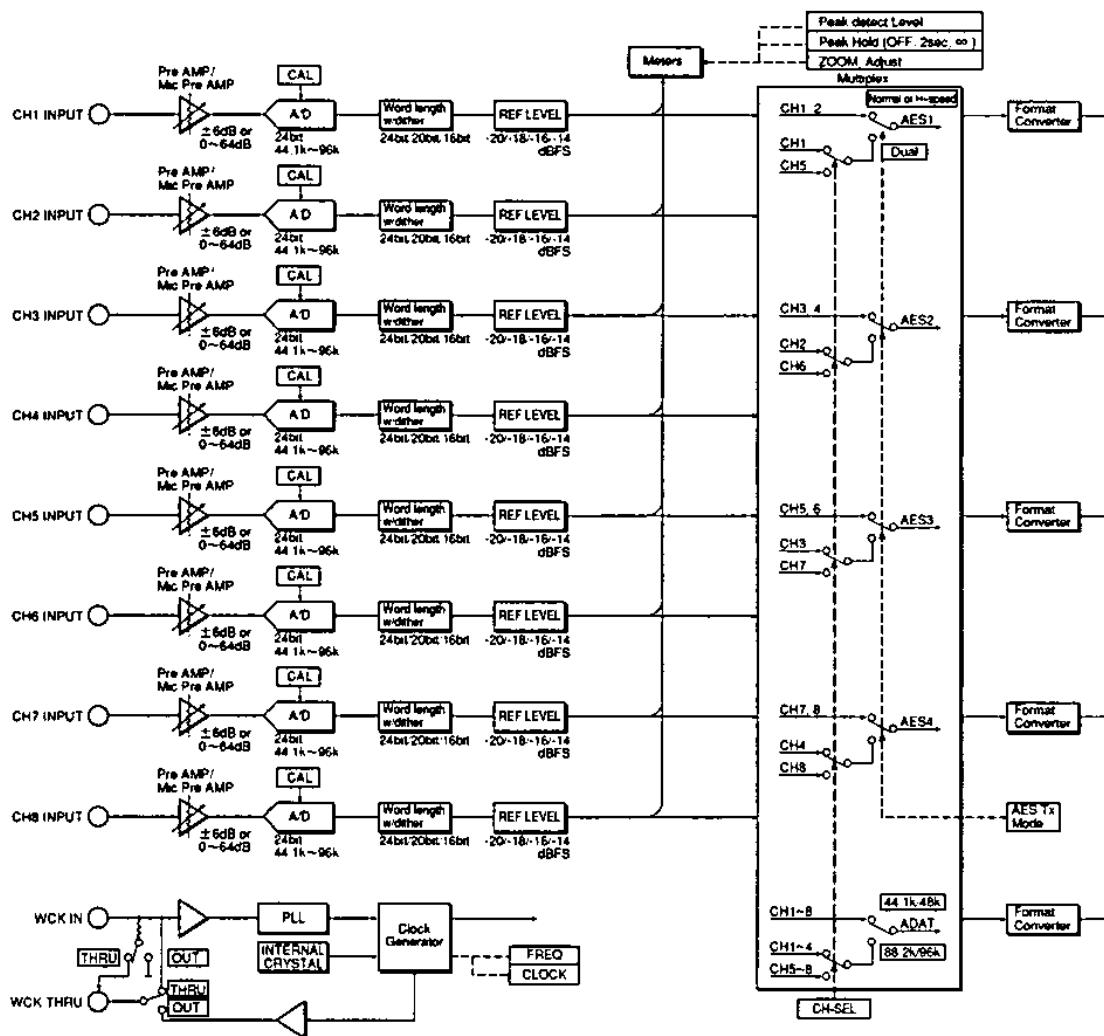

After passing the multiplex stage, the digital audio data are converted to the selected format, then supplied to AES1-4 and ADAT connectors. Output channel selection is made on the front panel in the shift mode operation.

On the bottom of the chart, the clock system is shown.

ADJUSTMENT AND SETTING

DIP SWITCH SETTING

On the Rear Panel an 8-bit DIP switch is provided. Following pages in this chapter describe more information on each function. Default settings are marked with *.

Switch # 7 and 8 select the reference level.

SW#	Reference Level (in dBFS)			
	-20	-18	-16	-14
8	Off*	Off	On	On
7	Off*	On	Off	On

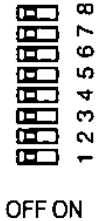

Switch # 6 will function if internal setting is changed. See the next chapter.

SW#	Wordclock output	
	Follows Sampling Frequency	Follows AES Output Rate
6	Off*	On

Switch # 5 through 3 select the peak detection level from among 8 options.

SW#	Peak Detection Level (in dBFS)			
	-6.0	-5.0	-4.0	-3.0
5	Off*	Off	Off	Off
4	Off*	Off	On	On
3	Off*	On	Off	On

SW#	Peak Detection Level (in dBFS)			
	-2.0	-1.0	-0.5	0.0
5	On	On	On	On
4	Off	Off	On	On
3	Off	On	Off	On

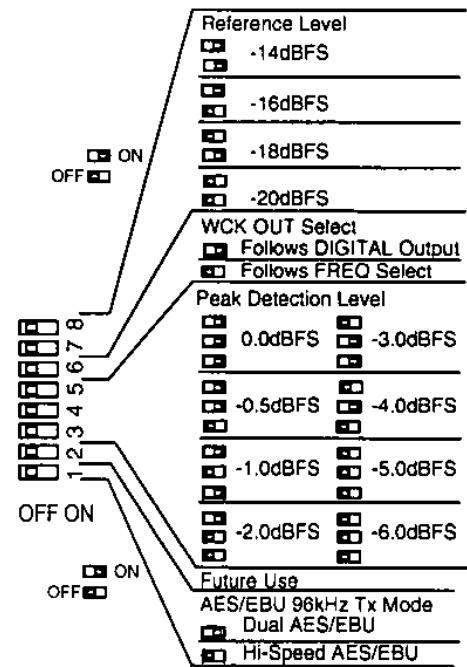

Switch # 2 does not function.

Switch # 1 selects the AES/EBU mode for 96 kHz operations.

SW#	AES/EBU Tx Mode Selection	
	Hi-Speed Single Wire	Dual mode
1	Off*	On

PRECISE LEVEL ADJUSTMENT FOR AD 96

1. Press **<SHIFT>** button for 2 seconds or more to enter SHIFT operation mode.
2. Press **<Level Adjust> LED Button** to enter the level adjustment mode. The LED lights in red during the mode.
3. Supply +4 dBu signal from a generator to the input connector.
4. Rotate the trimmer with a screw driver so that both the PEAK and REF LEDs light simultaneously. LEDs will display how the trimmer adjustment proceeds as illustrated below.

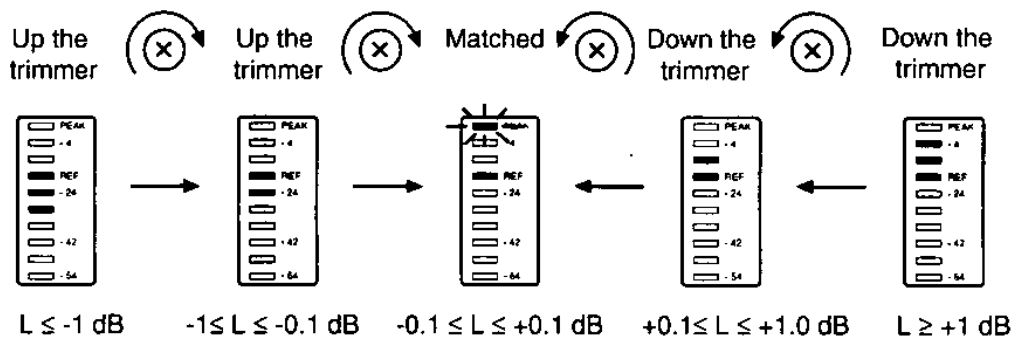

5. Repeat step 3 and 4 for the rest channels.
6. Press **<Level Adjust> LED Button** to quit the level adjustment mode.
Or, press **<SHIFT>** button to quit the SHIFT mode operation.

LEVEL ADJUSTMENT FOR AD 96M

Factory setting is +4 dBu = -20 dBFS* when the trimmer is turned to the end CCW position.

1. Connect a microphone to the input connector of the channel you will adjust. Then speak to the mic.
2. Adjust the trimmer so that the LED lights in amber (REF) when input is average, and occasionally lights in red (PEAK).
3. Repeat above steps for the rest channels if necessary.

REF LEVEL SETTING

Select the Reference Level by setting DIP switch # 8 and 7 on the rear panel to meet the connected device's: from -20, -18, -16 or -14dBFS.

For example, when TASCAM DA88 is connected use -16 dBFS. [-16] of REF LEVEL indicator lights on the front panel. This setting changes REF LEVEL for all 8 channels at once.



Level matching in digital audio is quite different from analog world's. Among analog devices it is simply accomplished just by referring to +4dBu, even though individual head rooms are not the same.

In digital world the gap of head room adversely affects on level matching, resulting in clips and so forth. To easily eliminate the gap an idea of [REF LEVEL] is introduced that indicates a minus digital scale from 0 dBFS (Digital Full Scale). As listed below, individual equipment has its own [REF LEVEL] equivalent to +4 dBu. Select an appropriate REF level by the DIP switch.

-14 dBFS: RAMSA WR-DA7, YAMAHA 03D, Lexicon PCM90/91

-16 dBFS: TASCAM DA88, AKAI DR8/DR16, Alesis ADAT XT (-15 dBFS)

-18 dBFS: Panasonic DAT SV-3900/4100/3700, Digidesign Pro Tools 888 I/O

-20 dBFS: RAMSA WR-DA7V, YAMAHA 02R, Others

WORD LENGTH SELECTION

Select a Word Length that meets to the connected device's by pressing the WORD LENGTH button on the front panel. If 16 or 20 bit is selected dither is added to moderate distortions caused by discarded bits.

TX MODE SELECTION

Data transmission formats are selected to meet the connected device's and system requirements.

- **AES/EBU Output**

Select an output mode by DIP switch #1 on the rear panel.



The high sampling signal has a double density information than the normal. There are two transmission modes extended from the normal AES/EBU Tx mode. The AD converter transmits either one of extended modes.

<i>Tx mode</i>	<i>Channel/Wire</i>	<i>Tx Rate</i>	<i>Typical device</i>
AES/EBU(Normal)	2	44.1/48 kHz	
Dual AES (Dual Wire)	1	44.1/48 kHz	MTRs Genex Recorder
Hi-speed (Single Wire)	2	88.2/96 kHz	Processors Tc Electronics

- **Dual AES Output Card**

This is an option card to enable the AD converter supplying 8 channel output in Dual AES/EBU mode.

- **ADAT, TDIF Output**

An optical output : Dual track mode, 24 bit, 96 kHz, 4 channel is supplied.

- **Output channel**

Selecting CH1-4 or CH5-8 is implemented in SHIFT operation mode.

WORDCLOCK SELECTION

Wordclock In setting is required.

- **Wordclock In**

The AD Converter examines input wordclock frequency to have the internal system clock synchronized to the input: 44.1, 88.2, 48 or 96 kHz. Contrary to the Wordclock In, sampling frequency is selected manually on the front panel by pressing the **FREQ** button.

PEAK DETECTION

The peak dots in the meters can be utilized in many ways; as a peak indicator alerting that the level reaches just prior to the clip, or as a clip indicator: respectively to the setting. Set the DIP switch #5-3 to -3 dB for use of a peak meter, or to 0 dB for use of a clip meter. Furthermore 0 dB if the source is percussive +2, 1 or 0.5 dB can be set to rust the peak detection.

AD CONVERTER CALIBRATION

The ambient temperature and AC voltage drift while using that may affects on the conversion accuracy. The AD converter has automated calibration. Manual calibration is also available to make the conversion optimum.

1. Press WORD LENGTH button for 2 seconds or more to enter SHIFT operation mode.
2. Press CAL button. While the calibration is carried out, ERROR LED lights and the outputs are muted.

RESUME AND CLEAR THE STORED DATA

• Resume

The AD converter retains following data while the power is off , and resumes when turning on. Marked with * are default values that the AD converter reloads when Memory Clear is implemented.

Peak Hold: OFF*/2 s/Infinity

Meter Mode: Normal*/ Zoom

Clock Frequency: 48*/ 44.1/96/88.2 kHz

Clock Source: Internal*/External

Word Length: 24*/20/16 bit

Out Channel Selection: 1-4*/ 5-8

• Memory Clear

To return the data back to the default, press the POWER switch while holding down the [FREQ/CH SEL] and [CLOCK/CAL] button simultaneously.

SELF DIAGNOSIS

The diagnosis program examines following items.

- Press the POWER switch while holding down the [FREQ/CH SEL] and [WORD LENGTH/SHIFT] button simultaneously. The program starts, then proceeds automatically to the end.

Backup Memory Check: If any error detected, the memory is initialized to the default.

CPU-LSI Communication Check: If any error detected, all the LED blinks on the front panel. To escape from error indication press the [FREQ/CH SEL] and [WORD LENGTH/SHIFT] button simultaneously, then contact the nearest service center.

LED Check: All the LED lights on the front panel.

Front Panel Button Check: Press the button one by one, the LED responding to the button turns off.

DIP Switch Check:

AD96: The bar graph LEDs (10-point) on the 8th channel indicate the switch status. The LED lights when the switch is On, or does not light when it is Off. DIP switch #1 status is displayed in the PEAK position and descending #2, 3, and so forth.

AD96M: PEAK/SIGNAL LEDs of eight channels indicate the switch status. The LED lights when the switch is On, or does not light when it is Off. DIP switch #1 status is displayed in the CH 1 position and corresponding to #2, 3, and so forth.

- Turn off the AD converter when the diagnosis is completed.

KEY LOCK





To protect the settings from mischief or mis-operation, this setting enables the buttons on the panel to be inactive. Pressing buttons is ignored when this is set to On except rotating trimmers and power On/Offs.

- To activate Key Lock turn on the POWER switch while holding down the [CLOCK/CAL] and [WORD LENGTH/SHIFT] buttons simultaneously.
- To quit Key Lock press [WORD LENGTH/SHIFT] button for 2 seconds or more.

INTERNAL SETTING & OPTIONS

Warning!

Internal setting, option card installation, and rack mounting should be made by qualified service personnel or system installers only.

	CAUTION RISK OF ELECTRIC SHOCK DO NOT OPEN	
<p>CAUTION: TO REDUCE THE RISK OF ELECTRIC SHOCK, DO NOT REMOVE COVER (OR BACK), NO USER SERVICEABLE PARTS INSIDE. REFER SERVICING TO QUALIFIED SERVICE PERSONNEL.</p>		
 SA 1965	<p>The lightning flash with arrowhead symbol, within an equilateral triangle, is intended to alert the user to the presence of uninsulated "dangerous voltage" within the product's enclosure that may be of sufficient magnitude to constitute a risk of electric shock to persons.</p>	
 SA 1966	<p>The exclamation point within an equilateral triangle is intended to alert the user to the presence of important operating and maintenance (servicing) instructions in the literature accompanying the appliance.</p>	

Internal setting

WORDCLOCK-OUT SETTING

In default setting the Wordclock THRU terminal supplies looped through output of the Wordclock IN. Changing setting inside the unit enables the wordclock terminal to supply internal clock to the connected device.

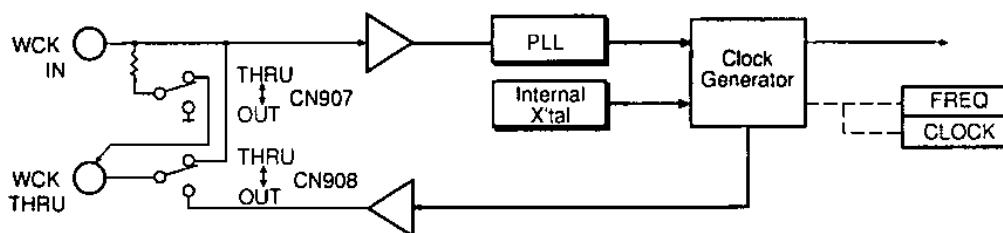

Wordclock Block Diagram

After this setting Wordclock IN constantly turns on the 75Ω termination while the Wordclock THRU feeds internal clock.

Setting the DIP switch # 6 will select whether the unit follows the sampling frequency or the clock selected .

Off: Wordclock THRU synchronizes to the sampling frequency selected by the FREQ button.

On: Wordclock THRU synchronizes to the data transmission (output) rate selected by the CLOCK button.

Options

DUAL AES OUTPUT CARD

This card supplies an 8-channel, 24 bit, 96 kHz signal to the connected MTRs. For more information see instructions attached to the card.

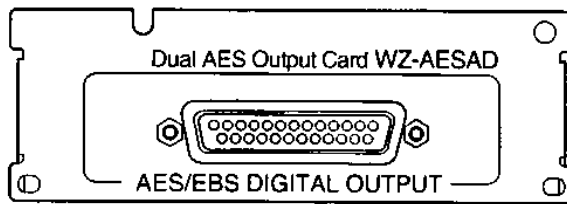

Pin Assignment

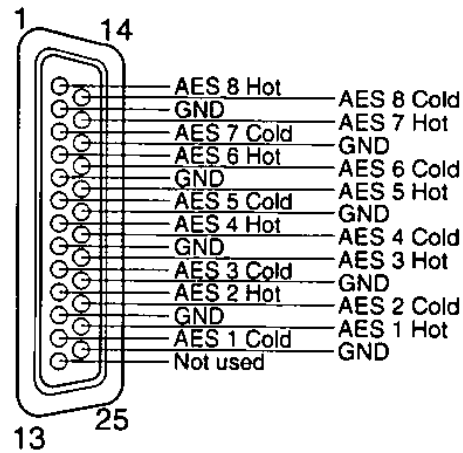

Recommended Cable

Panasonic part # **DA/DB-XLRM** (DB-25 to 8 Male XLR, Length 3m), AD Output cable is recommended.

TDIF OUTPUT CARD

This card converts an 8-channel/24-bit/48kHz or 4-channel/24-bit/96kHz data to TDIF format to connect the AD converter with an external DTRS, digital taperecorder such as TASCAM DA88.

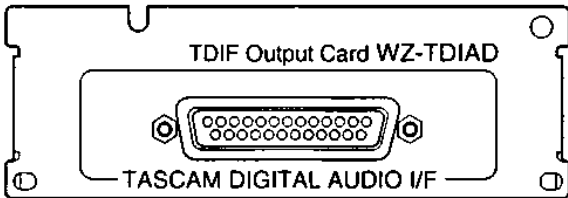

Pin Assignment

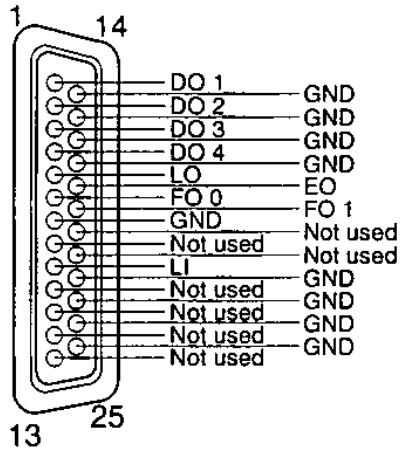

Recommended cable

For use with this card in one to one connection, Panasonic part # DA/DB-TDIF (DB25 to DB25(TDIF), Length 3m) is recommended. PW-88D (1m) or PW-88DL (5m) supplied by TASCAM are also recommended.

Other than one to one connection, you may need a Y cable shown in the next page for use with this card, a DTR and a DA converter at the same time.

DB25 Y CABLE

To connect the AD converter (TDIF Card installed) with the DA converter WZ-DA96 and a DTRS device (DA88 and so forth) you need to build a Y cable shown below.

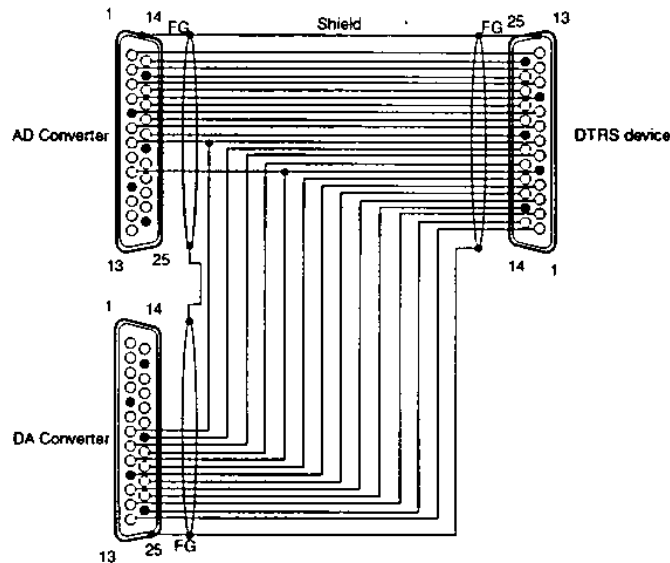

MOUNTING IN THE RACK

The AD converter is installed in an EIA 19" rack as follows.

- Install the AD converter in the rack by using four screws (standard accessory).

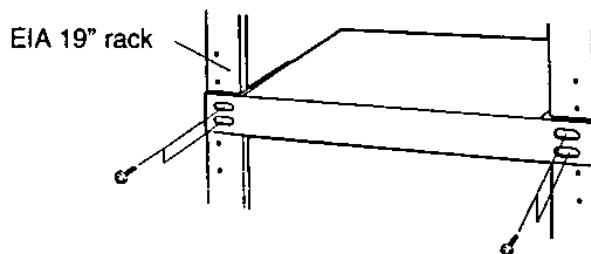

Caution:

- Before mounting make sure that the rack mounting brackets on both sides the unit are fixed with screws.
- Do not block the ventilation opening or slots on the cover to prevent the appliance from overheating. Always keep the temperature in the rack within 45°C (113°F).
- Secure the rear of the appliance to the rack by using additional mounting brackets (procured locally) if the rack is subject to vibrations.

CONNECTING THE SYSTEM

System examples are shown in following pages.

Connection - 1: Connecting with the DA7 Digital Mixer

Connection - 2: Connecting with the ADAT & BRC

Connection - 3: Connecting with TDRS

Connection - 4: Connecting with Pro Tools

CONNECTING WITH THE DA7 DIGITAL MIXER (CONNECTION 1)

Wordclock master : WR-DA7, AD Converter: To sync to DA7

• Connection

1. Connect between Wordclock-Out (75Ω=ON) on the DA7 and Wordclock-In on the AD converter with a BNC cable.
2. Connect between Wordclock-Out on the AD converter #1 and Wordclock-In on the converter #2 with a BNC cable.
3. Connect between ADAT-Outs on the AD converters and ADAT-Ins on the WR-ADAT cards installed in the DA7 with two optical cables.
4. Connect between ADAT-Out on the ADAT card #3 and DIGITALT-In on the ADAT with an optical cable.
5. Connect between ADAT- IN on the ADAT card #3 and DIGITALT-OUT on the ADAT with an optical cable.
6. Connect between the DA7 and the DAT: Rec Out to AES/EBU In and 2TR A In to DAT Out with two XLR cables.

• Setting

1. On the DA7, set the SOURCE SELECT to "INT 44.1 K" or "INT 48 K", and set the SLOT 3 of the DIGITAL INPUT SELECT to INPUT 9-14 and 15/16, in the [D-I/O> INPUT SET] window.
2. Set SLOT 3 to INS in the [D-I/O>TO SLOT] window to function SLOT 3 in send-return mode.
3. On the front panel of the AD converter, select "EXT" by pressing the CLOCK button to be slaved to DA7's wordclock. Set both the DIP switch #7 and 8 to ON to meet the REF level of -14dBFS.

- On the ADAT, select "DIG" by pressing the CLOCK SELECT switch to sync to the digital input.

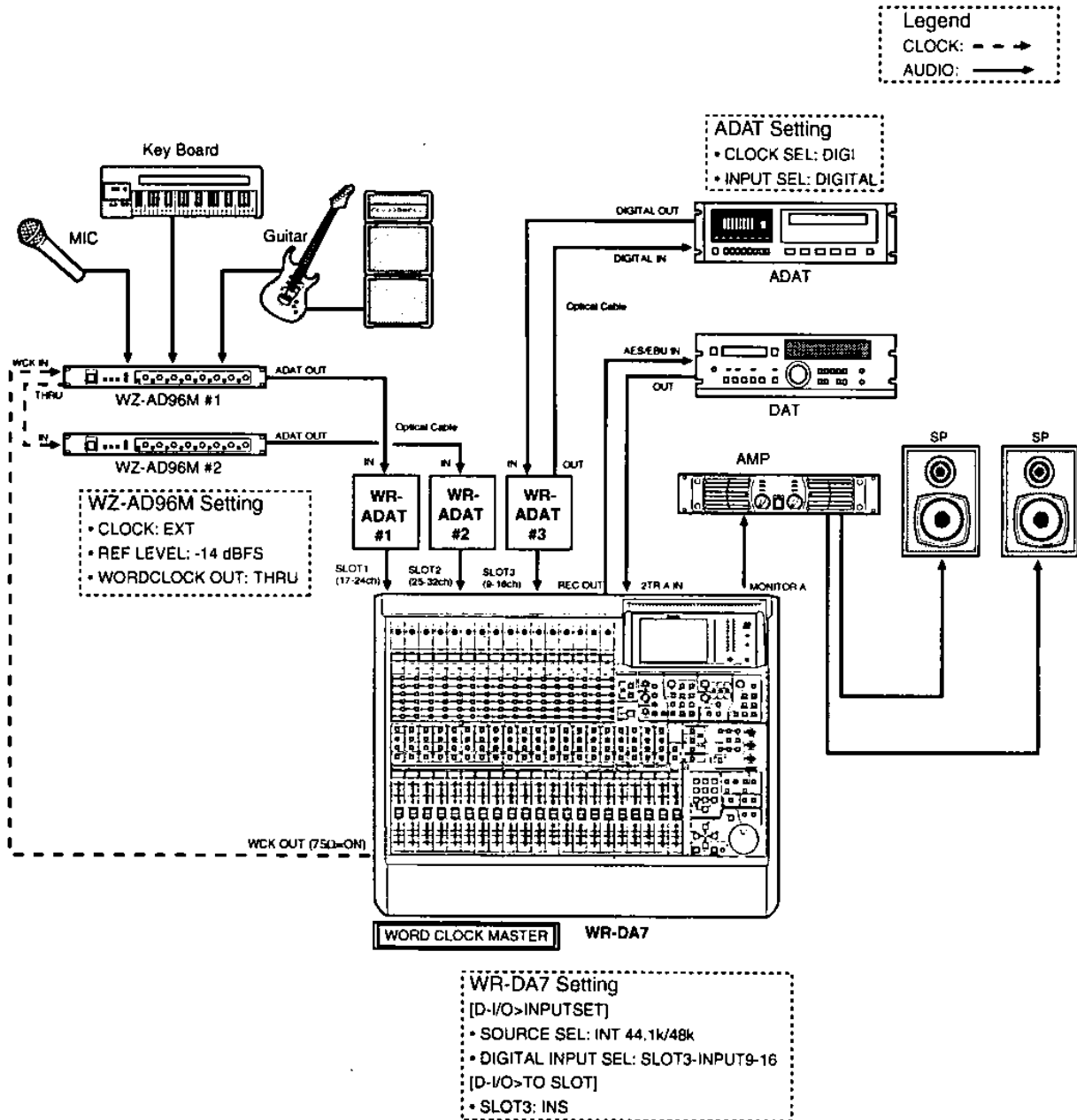

CONNECTING WITH THE ADAT & BRC (CONNECTION 2)

Wordclock master: WZ-AD96/96M AD Converter

• Connection

1. Connect between Wordclock-Out on the AD converter and WCK In on the DA converter with a BNC cable. In addition connect between WCK THRU on the DA converter and 48 kHz In on the BRC with a BNC cable. Note that inside the AD converter both CN907 and 908 jumpers are set to "OUT" positions.
2. Connect between ADAT Out on the AD converter and Digital-In on the ADAT with an optical cable to transmit 1-8 channel digital audio data.
3. Connect between DIGITAL Out on the ADAT and ADAT-In on the DA converter with an optical cable to monitor the sound.
4. Connect between Remote Out to ADAT on the BRC and SYNC-In on the ADAT with a SYNC cable to control ADAT remotely and to take synchronization.

• Setting

1. On the AD converter, select "CRYSTAL" by pressing the CLOCK button to let it work as the wordclock master. In addition select a sampling frequency by pressing the FREQ button. Note that if 88.2 or 96 kHz is selected, move the DIP switch #6 to On to keep sending 44.1 or 48 kHz wordclock to the BRC and ADAT.
2. Set the DIP switch on the AD converter #7 to Off and #8 to On to meet the REF level to -16 dBFS. See "REF Level Setting".
3. On the AD converter, select output channels: 1-4 or 5-8: after entering the SHIFT operation mode if 88.2 or 96 kHz is used. The selected channel outputs will be recorded on the ADAT's tracks: output channels "1, 2, 3 and 4" or "5, 6, 7 and 8" will be recorded onto track 1/2, 3/4, 5/6 and 7/8 respectively.
 - (1) To enter the SHIFT operation mode press the WORD LENGTH button for 2 second or more.
 - (2) Press the FREQ button to select output channels. The FREQ LEDs indicate the selection.
 - CH 1-4: The FREQ LED 44.1k/88.2k lights.
 - CH 5-8: The FREQ LED 48k/96k lights.
4. On the BRC, select "48 k Input" by pressing the EXT SYNC switch to sync to the wordclock.

- On the ADAT's front panel, press the DIGITAL IN switch to receive digital audio input.

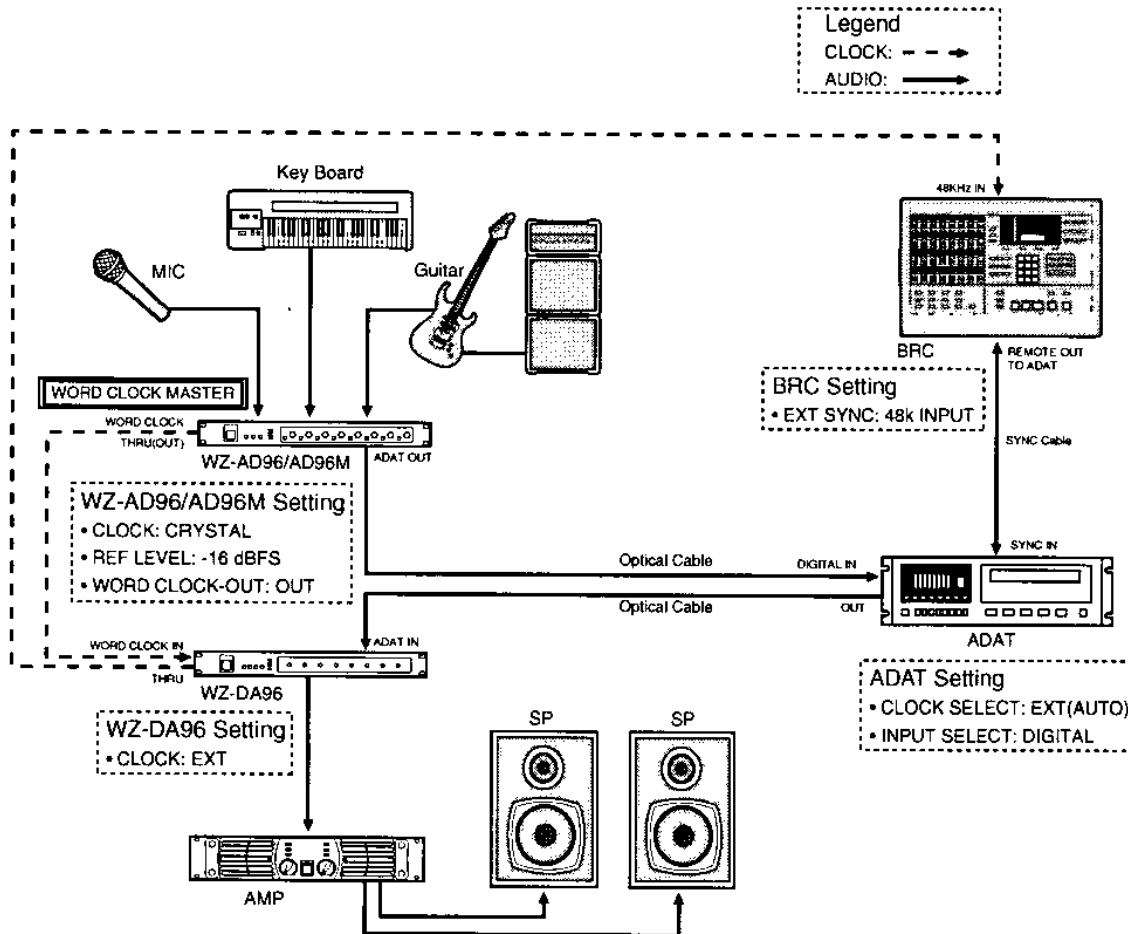

Connection-2

CONNECTING WITH TDRS (CONNECTION 3)

Wordclock master: WZ-AD96/96M AD Converter

• *Connection*

1. Install the TDIF card, an option to the AD converter, into the rear slot. See instructions attached to the card for more details.
2. Connect between Wordclock-Out on the AD converter and WCK IN on the DA converter with a BNC cable. In addition connect WCK THRU on the DA converter and WORD SYNC In on the DA88 converter with a BNC cable. Note that inside the AD converter both CN907 and 908 jumpers are set to "OUT" positions.
3. Connect TDIF Out on the AD converter and TDIF In on the DA88 with a DB25 Y cable as illustrated. In addition connect one end of the DB25 Y cable to the TDIF In on the DA converter to monitor the sound. See page 40 for detailed information on DB25 Y cable.

• *Setting*

1. On the AD converter, select "CRYSTAL" by pressing the CLOCK button, then select a sampling rate by pressing the FREQ button. Note that if 88.2 or 96 kHz is selected, move the DIP switch #6 to On to keep sending 44.1 or 48 kHz wordclock to the DA88.
2. Set the DIP switch on the AD converter #7 to Off and #8 to On to meet the REF level to -16 dBFS. See "REF Level Setting".
3. On the DA88, select "WORD" by pressing the CLOCK switch to let it sync to the wordclock.
4. On the AD converter, select output channels: 1-4 or 5-8: after entering the SHIFT operation mode if 88.2 or 96 kHz is used. The selected channel outputs will be recorded on the DA88's tracks: output channels "1, 2, 3 and 4" or "5, 6, 7 and 8" will be recorded onto track 1/2, 3/4, 5/6 and 7/8 respectively.
 - (1) To enter the SHIFT operation mode press the WORD LENGTH button for 2 second or more.
 - (2) Press the FREQ button to select output channels. The FREQ LEDs indicate the selection.
 - CH 1-4: The FREQ LED 44.1k/88.2k lights.
 - CH 5-8: The FREQ LED 48k/96k lights.
5. On the DA88's front panel, press the DIGITAL IN switch to receive digital audio input.

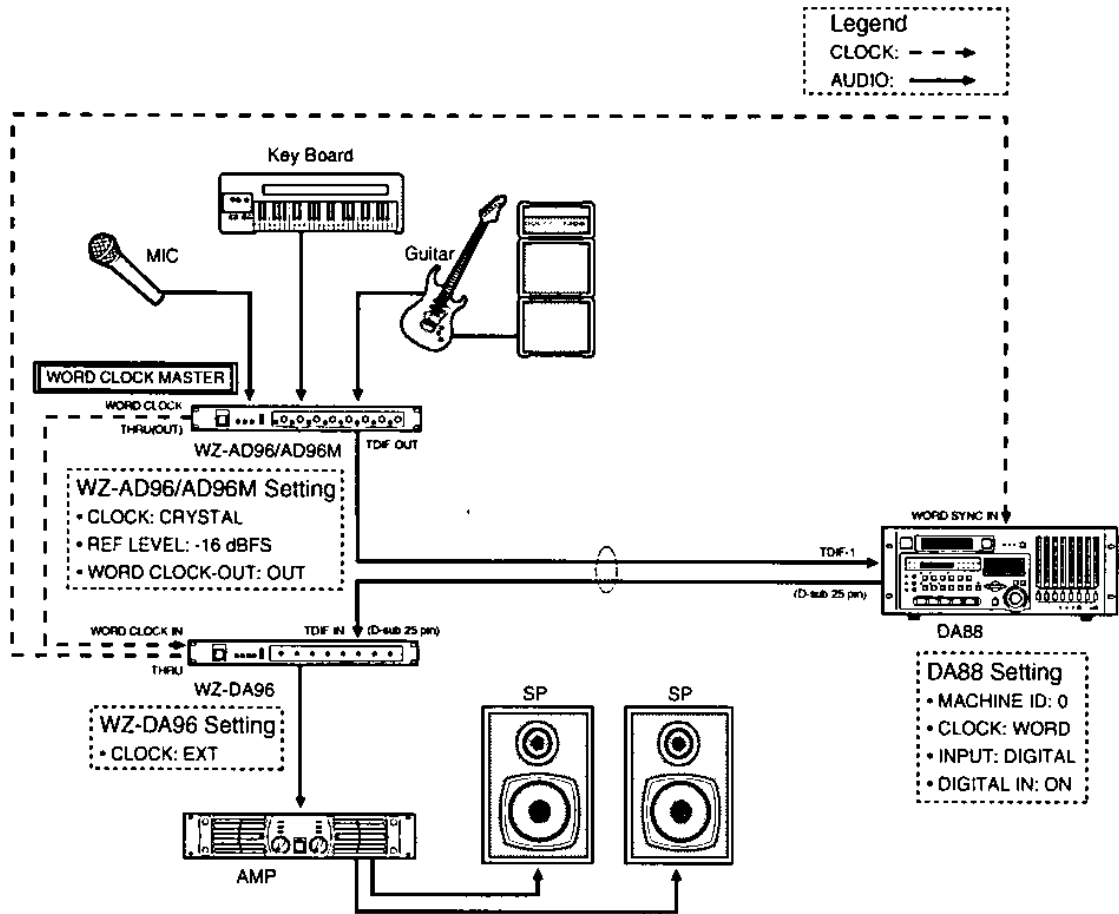

Connection-3

CONNECTING WITH PRO TOOLS (CONNECTION 4)

Wordclock master: Pro Tools 888 I/O

• *Connection*

1. Connect SLAVE CLOCK OUT on the 888 I/O #1 and SLAVE CLOCK IN on the 888 I/O #2 with a BNC cable. Then connect between #2 and #3 in the same way as #1 and #2.
2. Connect SLAVE CLOCK OUT on the 888 I/O #3 to WCK In on the DA converter with a BNC cable.
3. Connect WCK Out on the DA converter and WCK In on the AD converter #1 with a BNC cable. Then, connect between Wordclock-Out on the AD converter #1 and Wordclock-In on the AD converter #2 with a BNC cable. In the same manner connect the AD converter #2, #3 and the DA converter with BNC cables.
4. Connect AES/EBU Out on the AD converter #1 and AES/EBU In on the 888 I/O #1 with XLR cables. For #2 and #3 connect in the same manner.
5. Connect between the AES/EBU Out on the 888 I/O #1 and AES/EBU In on the DA converter with XLR cables to monitor the sound.

• *Setting*

1. Set SYNC MODE to "INTERNAL", and select SAMPLE RATE from 44.1k or 48k on the 888 I/O #1.
2. Set Channel 1-8 INPUT to "DIGITAL", and 1-2 FORMAT to "AES/EBU" on the 888 I/O #1-3.
3. On the AD converter select "EXT" by pressing the CLOCK button, and set the DIP switch #7 to On and #8 to Off to meet the REF level to -18 dBFS. See "REF Level Setting".

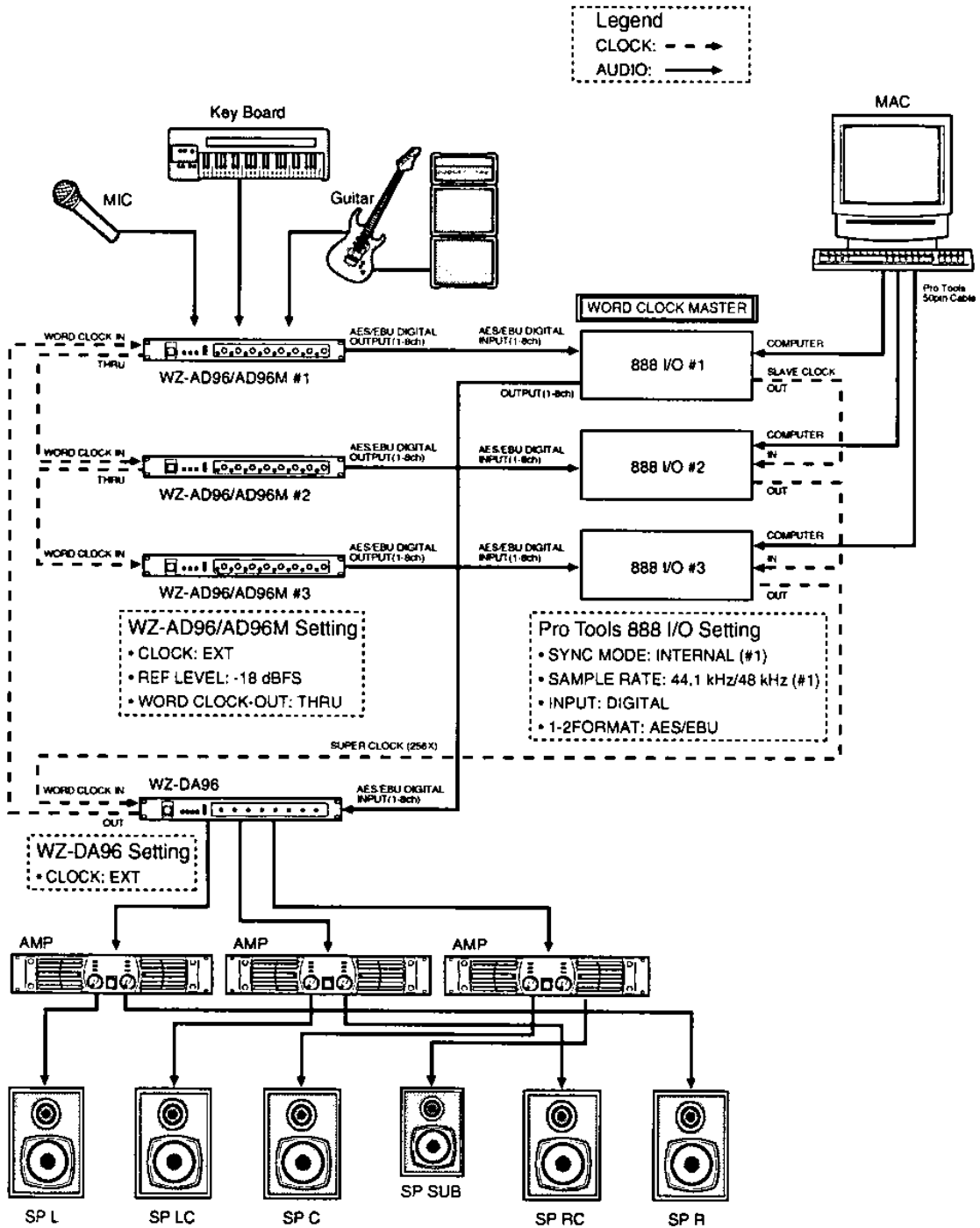

Connection-4

TECHNICAL SPECIFICATIONS

GENERAL	WZ-AD96	WZ-AD96M
Power requirement	AC 120 V 60 Hz	AC 120 V 60 Hz
Power consumption	18 W	19 W
Dimensions (mm)	480(W)x44(H)x350(D)	480(W)x44(H)x350(D)
(inch)	16-9/16(W)x1-3/4(H)x13-3/4(D)	16-9/16(W)x1-3/4(H)x13-3/4(D)
Weight	5 Kg(11 lbs)	5 kg(11 lbs)

ANALOG INPUT

Analog In	XLR x 8	XLR x 8
Impedance	10 k Ω Balanced	10 k Ω Balanced
Maximum Input Level	+30 dBu (-6 dB trim)	+24 dBu
Trim Level	+4 dBu \pm 6 dB	
Input Gain Level		-60 dBu to +4 dBu
THD + N		
(+4 dBu, 20 Hz-20 kHz)	0.003%, 90.5 dB	0.003%, 90.5 dB
(+24 dBu, 20 Hz-20 kHz)	0.0003%, 110.5 dB	0.0004%, 110.5 dB
Dynamic Range	118 dB	117 dB
E.I.N		-128 dB
Group Delay (at 48 kHz)	38.7/Fs sec (0.806 ms)	38.7/Fs sec (0.806 ms)
Channel Separation	114 dB	113 dB
Frequency Response		
(+4 dBu, 20 Hz-20 kHz)	+0.0 dB -0.2 dB	+0.0 dB -0.2 dB
C.M.R.R (at 1 kHz)	\geq 70 dB	\geq 80 dB
Sampling Rate	44.1 kHz - 96 kHz	44.1 kHz - 96 kHz
Resolution	24 bit	24 bit

DIGITAL IN & OUT

Meter		
Type	Bargraph	Signal/Reference/Peak
	10-point	1- point, 3-color
Accuracy	\pm 0.05 dB	\pm 0.05 dB
Peak-Hold	2 s / ∞ / Off	-
Mode	Normal/Zoom/Adjust	-

DIGITAL IN & OUT

Wordclock In	BNC x 1, 75 Ω auto-termination
Wordclock Out	BNC x 1, Looped-thru or Internal Out
ADAT Out	Optical x 1
Format	24bit, Normal/96k Dual Channel
AES/EBU Output	XLR x 4
Format	24bit, Normal/96k Hi-Speed Single Wire/96k Dual wire
Dither	16bit, 20bit

STANDARD ACCESSORIES

Power Code	1
Screw	x4 (M5x10) For rack mounting
Rubber Foot	5

OPTIONAL ACCESSORIES

Dual AES 8ch Output Card (WZ-AESAD)

Output Connector	DB25
Format	AES/EBU (24 bit AES3-1992)
Signal Level	RS-422
Channel Mode	8 ch, 24-bit, 44.1/48 kHz, Normal AES 8 ch, 24-bit, 88.2/96 kHz, Hi-Speed AES 8 ch, 24-bit, 88.2/96 kHz, Dual AES
Dimensions	108(W) x 37(H) x 62(D) mm 4-1/4(W) x 1-7/16(H) x 2-7/16(D) inch
Weight	230 g (0.51 lbs)

TDIF OUTPUT CARD (WZ-TDIAD)

Output Connector	DB 25
Format	TDIF-1 (24bit Normal/96k Dual Channel)
Signal Level	CMOS Level
Channel Mode	8 ch, 24-bit, 44.1/48 kHz, Normal 4 ch, 24-bit, 88.2/96 kHz, Dual Channel
Dimensions	108(W) x 37(H) x 62(D) mm 4-1/4(W) x 1-7/16(H) x 2-7/16(D) inch
Weight	230 g (0.51 lbs)

LEVEL DIAGRAM

WZ-AD96

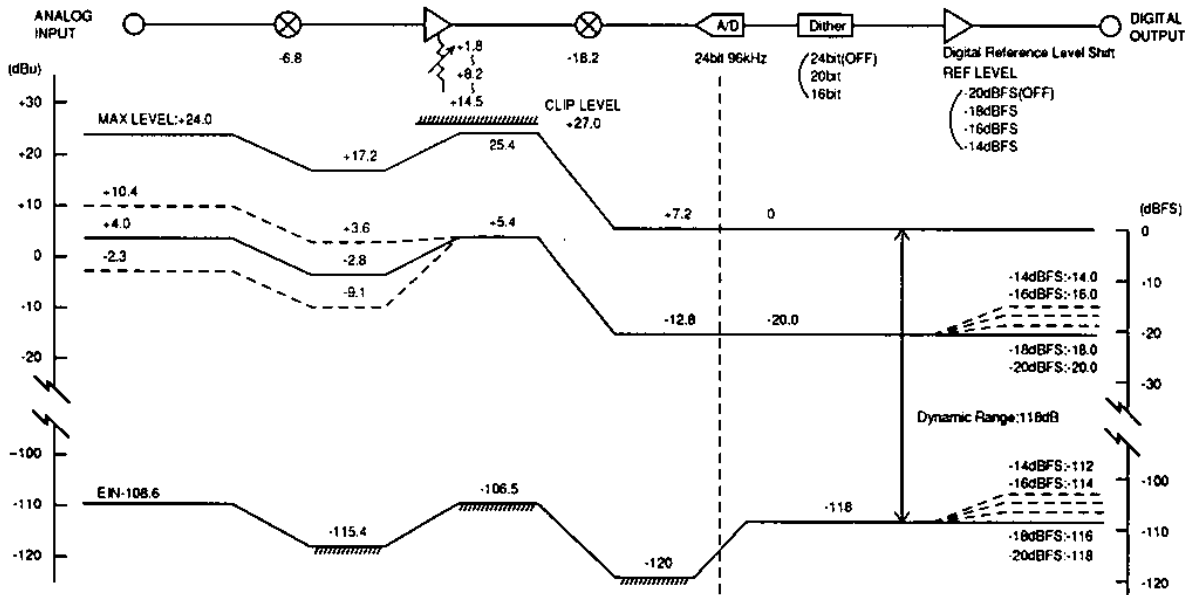

WZ-AD96M

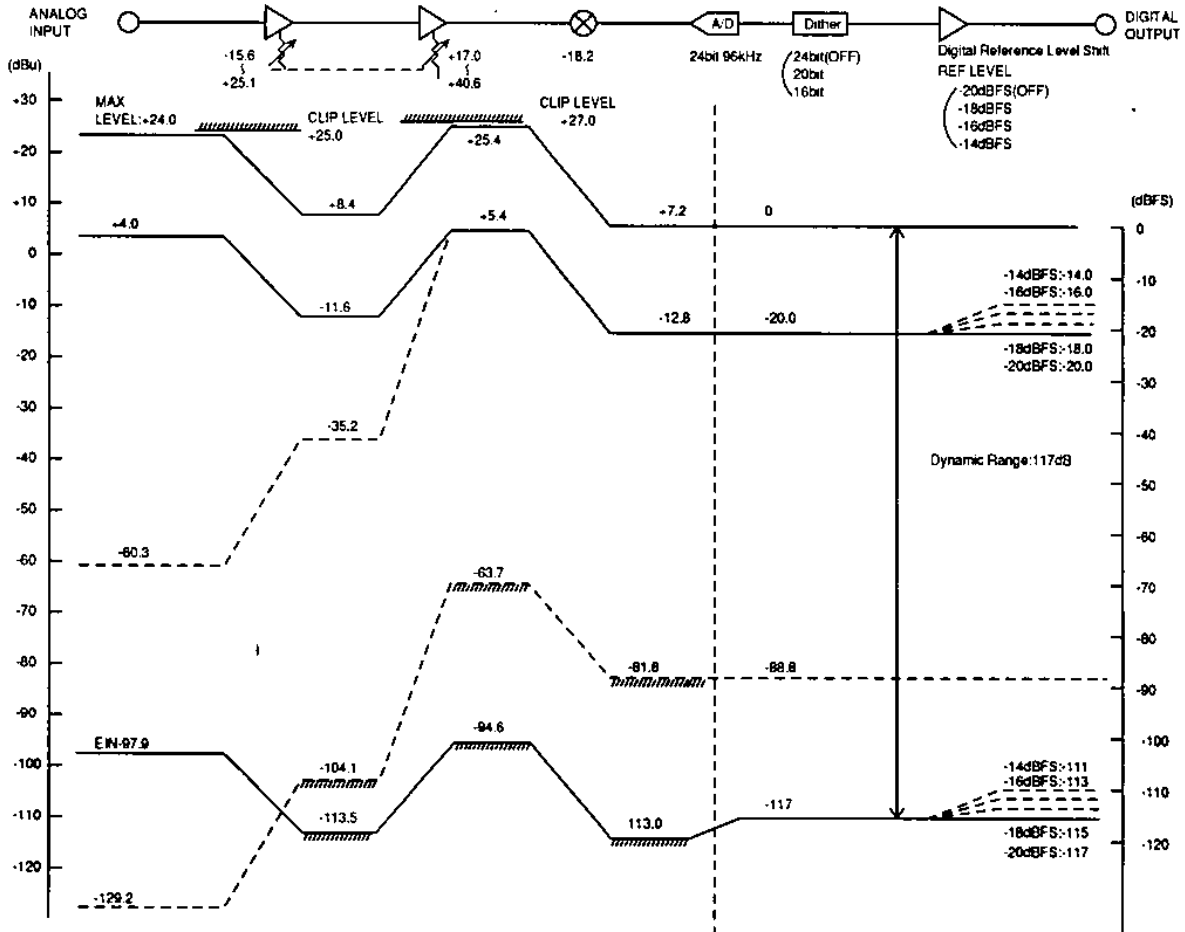

BLOCK DIAGRAM

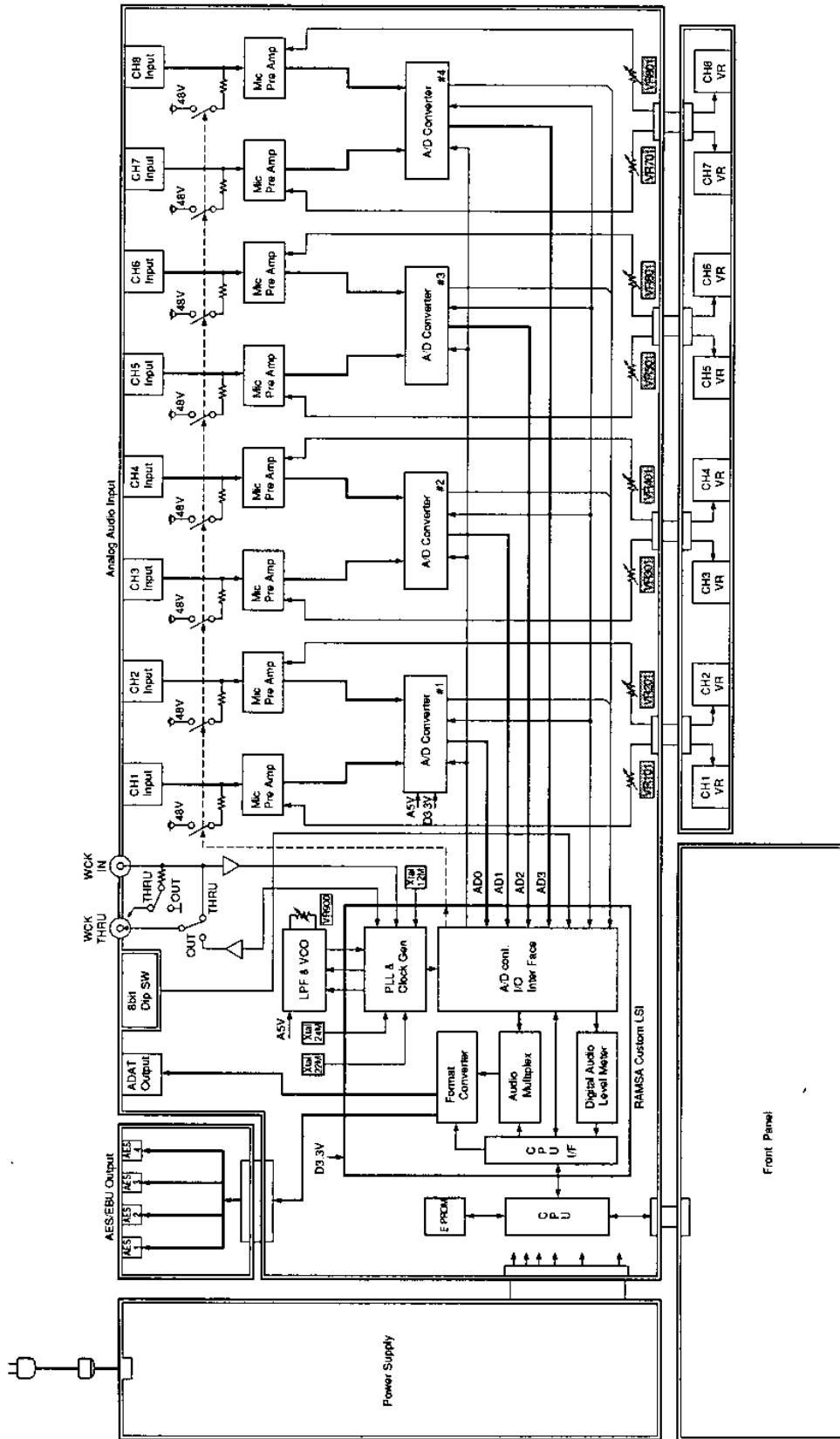

DIMENSIONS

WZ-AD96

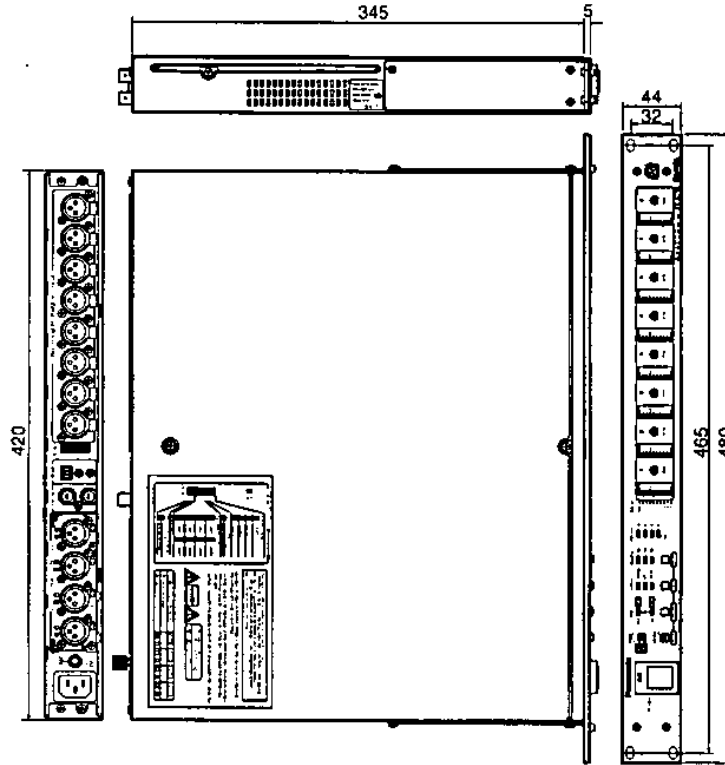

WZ-AD96M

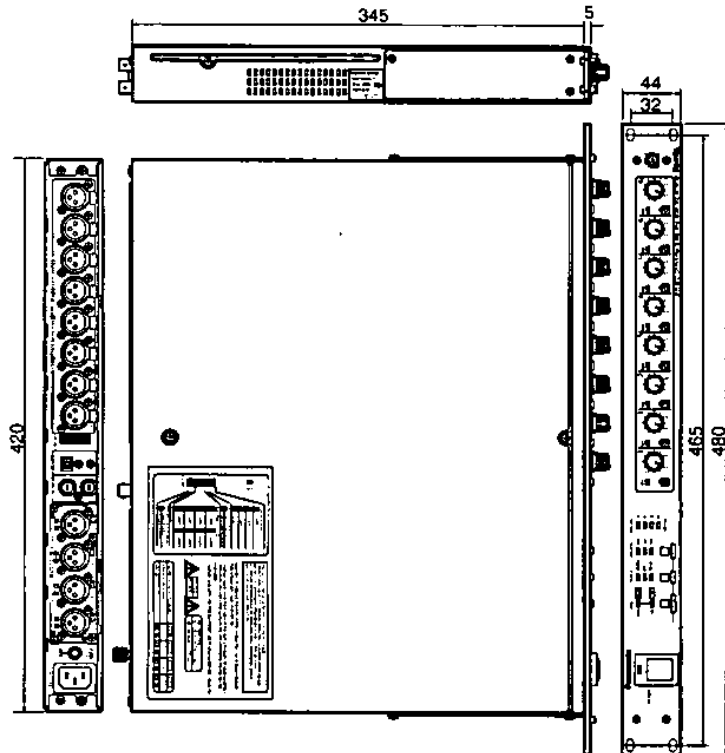

HIGH SAMPLING DIGITAL FORMAT

This section details the channel relationship between analog inputs and digital outputs depending on the format.

AES/EBU OUTPUTS ON THE REAR PANEL

Normal AES/EBU Mode

Word length=24 bit, Sampling rate=44.1/48 kHz, Tx rate=44.1/48 kHz

Analog Input CH #	Digital Output
1 & 2	AES 1
3 & 4	AES 2
5 & 6	AES 3
7 & 8	AES 4

Hi-Speed AES/EBU Mode

Word length=24 bit, Sampling rate=88.2/96 kHz, Tx rate=88.2/96 kHz

Analog Input CH #	Digital Output
1 & 2	AES 1
3 & 4	AES 2
5 & 6	AES 3
7 & 8	AES 4

Dual AES/EBU Mode

Word length=24 bit, Sampling rate=88.2/96 kHz, Tx rate=44.1/48 kHz

Analog Input CH #	Digital Output
1 or 5	AES 1
2 or 6	AES 2
3 or 7	AES 3
4 or 8	AES 4

DUAL AES/EBU OUTPUT CARD (OPTION)

Hi-Speed AES/EBU Mode

Word length=24 bit, Sampling rate=88.2/96 kHz, Tx rate=88.2/96 kHz

Analog Input CH #	Digital Output
1 & 2	AES 1
3 & 4	AES 2
5 & 6	AES 3
7 & 8	AES 4
1 & 2	AES 5
3 & 4	AES 6
5 & 6	AES 7
7 & 8	AES 8

Dual AES/EBU Mode

Word length=24 bit, Sampling rate=88.2/96 kHz, Tx rate=44.1/48 kHz

Analog Input CH #	Digital Output
1	AES 1
2	AES 2
3	AES 3
4	AES 4
5	AES 5
6	AES 6
7	AES 7
8	AES 8

ADAT OUTPUT ON THE REAR PANEL

ADAT Normal Mode

Word length=24 bit, Sampling rate=44.1/48 kHz

Analog Input CH #	Digital Output
1	TR1
2	TR2
3	TR3
4	TR4
5	TR5
6	TR6
7	TR7
8	TR8

ADAT Dual Track Mode

Word length=24 bit, Sampling rate=88.2/96 kHz

Analog Input CH #	Digital Output
1 or 5	TR1
1 or 5	TR2
2 or 6	TR3
2 or 6	TR4
3 or 7	TR5
3 or 7	TR6
4 or 8	TR7
4 or 8	TR8

TDIF OUTPUT CARD (OPTION)

Normal TDIF Mode

Word length=24 bit, Sampling rate=44.1/48 kHz

Analog Input CH #	Digital Output
1	TR1
2	TR2
3	TR3
4	TR4
5	TR5
6	TR6
7	TR7
8	TR8

TDIF Dual Track Mode

Word length=24 bit, Sampling rate=88.2/96 kHz

Analog Input CH #	Digital Output
1 or 5	TR1
1 or 5	TR2
2 or 6	TR3
2 or 6	TR4
3 or 7	TR5
3 or 7	TR6
4 or 8	TR7
4 or 8	TR8

SUB-CODE IN AES/EBU OUTPUT

The AD Converter uses following sub-codes.

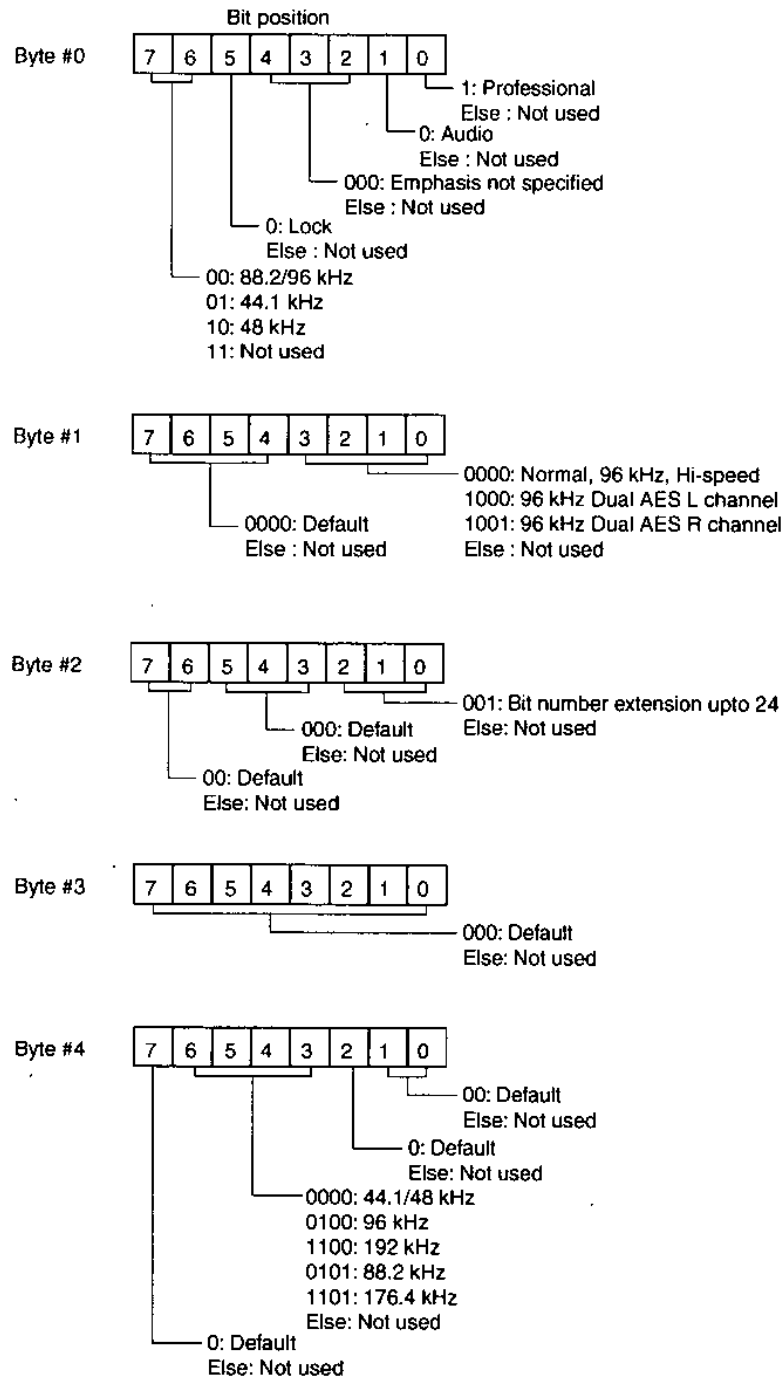

High Sampling Digital Format

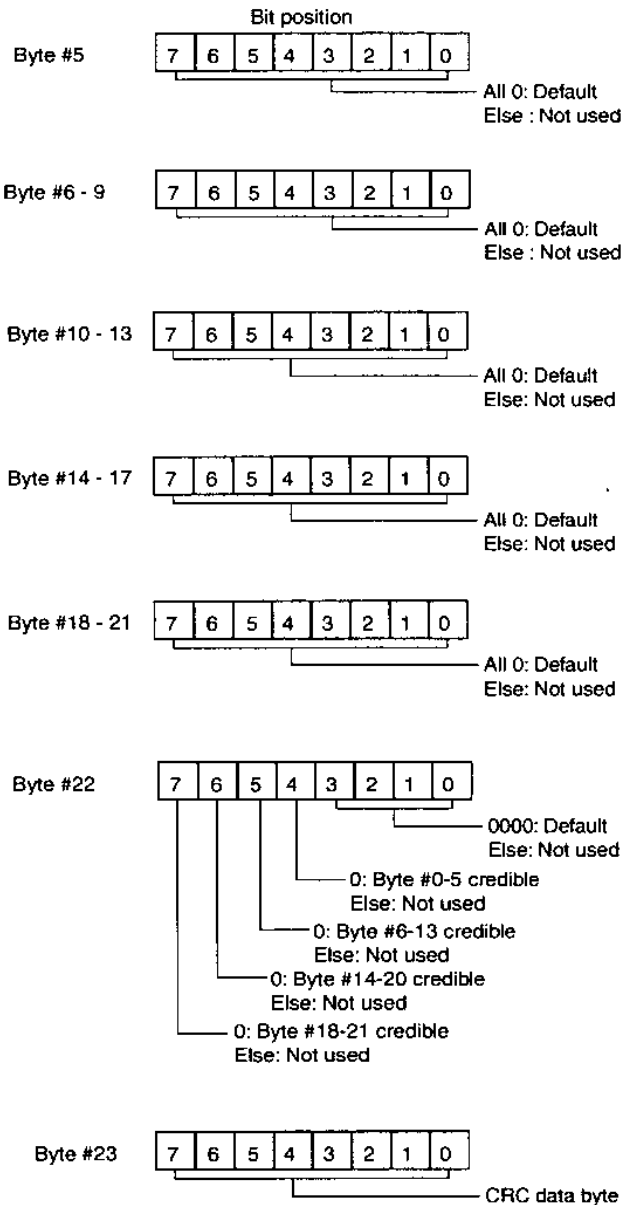

Panasonic Broadcast & Television Systems Company
Professional Audio Division
3330 Cahuenga Boulevard, Los Angeles, CA 90068 Telephone (323) 436-3500

N1299-0

YWA8QA5356AN
Printed in Japan

© Matsushita Communication Industrial Co., Ltd. 1999

Other ManualsLib Projects



www.manualslib.com



www.manualslib.de



www.manualslib.es



www.manualslib.fr



www.manualslib.nl



www.manualslib.mx



www.manualslib.tech 30+ Languages