

OVERLOUD GEMS

USER MANUAL

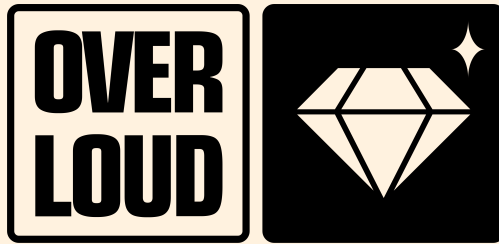

Rev. 1.13.1

TABLE OF CONTENTS

INTRODUCTION	1
WHY GEMS?	1
MENU BAR.....	5
COMP76	6
EQ495	9
TAPEDESK.....	10
EQ84.....	15
DOPAMINE.....	17
SCULPTUBE	19
EQ550	21
COMP G	22
ECHOSON.....	24
COMP670	28
OTD-2	30
COMP LA	33
VOICE.....	36
MODULA.....	40
MOD	44
EQP	45
SOLO	48
SCRIBBLES.....	49
PREFERENCES	51
LEGAL NOTICE	53

INTRODUCTION

OVERLOUD GEMS is a collection of top quality plug-ins for both mixing and mastering. We put the best DSP algorithms and hardware emulation techniques available into each **GEM** and enriched these products with additional parameters and features, a consistent preset management, A/B comparison and undo/redo support.

OVERLOUD GEMS come in the following plug-in formats: VST, AudioUnit, AAX plus a standalone application. All in both 32 and 64 bit, and for Mac and Windows. You will be able to load and use them in all common DAWs.

OVERLOUD GEMS licenses need to be authorized. To authorize a **GEM** please follow the instructions on our website: www.overloud.com in the AUTHORIZE section.

WHY GEMS?

In a world overcrowded by competing products doing just “the same thing”, how is it a good idea to develop another collection of audio plugins?

Well, because: First, they don’t actually do the same thing, and then, even in that case, they don’t do it in the same way.

*Here at **OVERLOUD** we have been developing high quality DSP effects these last several years, and with great passion and dedication. And as some of the best audio companies worldwide chose us for licensing our DSP effects, we realized that we are doing our job the right way.*

So we decided to take a selection of our effects and let our vision of high quality plugins meet reality, by wrapping these algorithms with gorgeous 3D graphical interfaces, and adding the wished-for features that are missing from the modeled real equipments.

After the first couple of plugins were delivered to beta testers, we discovered that what we were actually achieving was a collection of brilliant products with great sounding DSP plus a set of extra features that made each of them even more desirable.

The plugins looked precious and demonstrated that it was worth having them all. Like gems in a necklace.

There is a common denominator across all the Gems, which sits in the upper part of the user interface: the Gems bar. This bar contains the controls that are present across all Gems. Like Preset management, to mention one. This way, Gems users have a consistent interface to deal with for standard tasks.

- **COMP76**, the modeling of a legendary FET compressor, a piece of hardware which immediately became a reference among audio engineers right from its release at the end of '60s.

Notable features:

- *Added Revision selector, which lets you choose among three different unit models;*
- *Added Mid-Side processing, with a duplication of the interface to separately compress both the mono and stereo components of the signal using different settings;*
- *Added LF Sens control, which reduces the action of the compressor on the low end;*
- *Added Harmonics control to adjust the amount of generated harmonics;*
- *Added Parallel compression, which lets you sum the compressed signal along with the original to improve the overall impact by still keeping the transients intact;*

OVERLOUD GEMS

- *Ultra oversample mode for super accurate analog emulation.*
- **EQ495**, a very popular equalizer found in one of the most acclaimed vinyl transfer consoles from the '70s through to '90s.

Notable features:

- *Top quality and faithful modeling, to let you reproduce exactly the same tones as the real gear with no compromises;*
- *Super musical EQ curves, providing a unique tone not available on any other channel EQ.*
- **TAPEDESK**, another meticulous reproduction of the first microprocessor-controlled tape machine from the late '70s. And including models of three different history-making mixing consoles from the annals of analog recording: the same ones behind an endless number of world-class rock and pop hits from those years. Combinations still very appreciated today for the character of their mic-pre transformers and warm tape saturation.

Notable features:

- *Includes the models of three different mixing consoles in order to reproduce the whole signal path just as in the real world, where console channel strips definitely play their role in the final sound along with interactions with the tape machine itself;*
- *CPU load so low that you can use many instances, just as you would do in the real world: where individual console channels are recorded across multiple tracks on tape; and then, during playback, each track is summed through distinct mix channels back on the console.*
- **EQ84**, an iconic mic preamp and EQ module providing fat, smooth sounds.

Notable features:

- *Offers an additional mid range EQ band to improve flexibility;*
- *Original stepped knobs replaced by fully variable knobs to get smooth response and access to intermediate values; but still with "snapping" to the original static values;*
- *Cue listen feature available for each EQ filter, to easily understand what frequencies a band is processing.*
- **DOPAMINE**, a model of another couple of '70s-'90s ubiquitous equipments originally designed to encode and decode sound for noise reduction, but then was used to only encode signals for the surprising effect of "reviving" sounds with improved brilliance and clarity without overdoing it.

Notable features:

- *Two different module cards available for both generic and vocal sound processing;*
- *Enhances the signal without adding artificial harmonics as an exciter typically does.*
- **EQ550**, modeled after a renowned American EQ created with custom op-amps, it has become famous thanks to its unique Proportional-Q design, meaning that the bandwidth of the filters becomes narrow when the gain of the filter increases.

OVERLOUD GEMS

Notable features:

- *Unique Proportional-Q design, meaning that the bandwidth of the filters becomes narrow when the gain of the filter increases.*
- **COMP G**, reproduces faithfully the same dynamic response of one of the legendary compressors that made the story of studio mixing: the G series.

Notable features:

- *This is a slow rate VCA based compressor. All transients are preserved and the processed sound keeps clarity and freshness.*
- **ECHOSON**, accurate modeling of a very popular magnetic drum based echo machine.

Notable features:

- *Not a straight echo machine. Thanks to its great flexibility, it can also be used as a sort of reverb or even for more creative sound design contexts.*
- **COMP670**, models one of the most popular compressors widely used in music productions since 1950.

Notable features:

- *Very harmonic kind of compressor, with marked effect due to its 4 transformers.*
- **OTD-2**, models one a very well known stereo tap delay unit, greatly improving the original feature settings.

Notable features:

- *Very flexible kind of delay which can primarily be used as a sort of modulation to achieve rich chorus / flanger effects, while preserving the sound body and thickness.*
- **COMPLA**, reproduces two compressor units widely known for their particular sound character.

Notable features:

- *This generation of compressor units, based on electro-luminescent light coupled with a photoelectric cell, had big success in the past and their character is still appreciated even nowadays.*
- **VOICE**, is an original brand new Overloud Gem.

Notable features:

- *This vocal processor brings together the essential modules for the complete management of a vocal track.*
- **MODULA**, reproduces three popular modulation units.

Notable features:

- *Easily switch through the modulation models, double panels to enrich the processed sound, positively or negatively connect parameters to the sound envelope.*

OVERLOUD GEMS

- ***MOD**, includes one of the three **MODULA** models.*

Notable features:

- *Get the **MOD** gem for free. Have a taste of the modulation processing before possibly decide to upgrade to the **MODULA**.*
- ***EQP**, reproduces a suite of legendary EQ and other processors.*

Notable features:

- *Other than faithfully replicate the same tone and harmonic behaviour of the original unit, it includes a graphic display showing the current EQ curve.*

OVERLOUD GEMS

MENU BAR

All **OVERLOUD GEMS** have a menu bar at the top. The menu bar is identical across all Gems, and implements the same set of functions. Here is the description of this global menu bar.



POWER - Turns the “power” on or off for the Gem. This control actually works as a bypass: when it is set to off, the plugin transfers the input channel signal unaltered to the output.

PRESETS - The presets area includes four controls: left and right scroll buttons, the preset name box, and the drop-down list button. Each Gem can store an infinite number of presets. You can scroll through them sequentially with the left/right (previous/next) buttons, or by clicking the drop down list button which will list the presets, allowing you to scroll the list interactively and load a preset with a mouse click.

SAVE/SAVE AS - When you have edited the current preset, you can store it in the preset database with the SAVE button. If, instead, you want to duplicate it you can press SAVE AS and type a new name for the copy of the preset.

When you load a preset, its name appears in the preset name box. As soon as you change a preset after loading, you will see a dot next to the preset name; this dot indicates that the preset has changed. If you try to load a new preset after editing the current one, you will be prompted for confirmation that your real intention is to load the new preset and lose your changes.

A/B COMPARISON - The A and B buttons allow you to compare two sets of settings for the Gem. The version you are currently editing is the one highlighted in red, and you can switch to the counterpart by clicking the other button. You can copy the selected setting to the other one with the arrow button in between.

LINK - For Gems having parameters to be linked together, if the LINK control is not explicitly present on the Gem panel, this button can be used to access the list of linkable parameters and enable the wanted links. If one link is enabled at least, then the LINK button is lit.

UNDO/REDO - Each user action done inside the Gem is stored into an internal list. You can reverse these actions one step at a time to restore a previous setting. And even to redo the undone steps if you feel you went too far backwards.

COMP76

COMP76 is a top quality FET compressor modeled after one of the most popular hardware compressor units. It fits well on a whole mix, but its best application is on a single instrument or voice track.

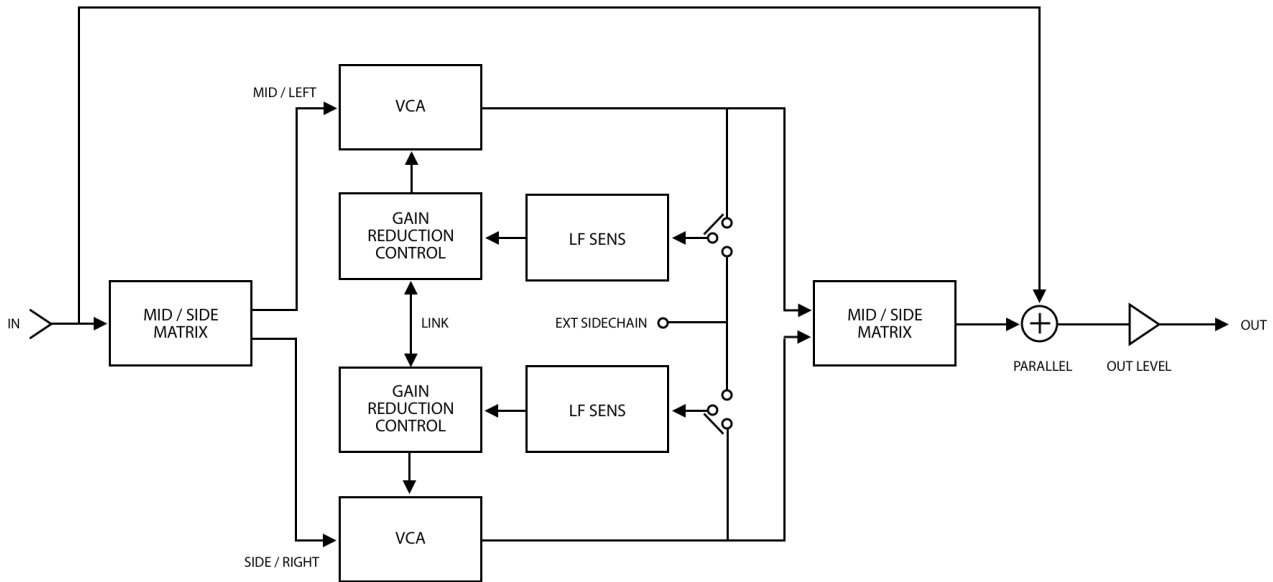

This diagram describes the **COMP76** internal sections and the way they are interconnected.



INPUT - Adjusts the level of the input signal and the threshold. Higher levels correspond to increased amounts of limiting or compression.

ATTACK - Sets the time it takes the **COMP76** to react to a peak of the input signal with gain reduction. The attack time ranges from 20 microsec-

When a short attack time is set, gain reduction happens immediately catching transient signals and reducing their level. The audible result is to soften the sound. Longer attack times let short transients pass before the limiting begins.

onds to 800 microseconds with the fastest attack time corresponding to the full counterclockwise position of the knob.

RELEASE - Sets the time it takes the **COMP76** to return to its no gain reduction state. The release time ranges from 50 milliseconds to 1100 milliseconds with the fastest release time corresponding to the full counterclockwise position of the knob.

RATIO - Selects how hard the gain reduction is applied. Each setting corresponds to how many input decibels will correspond to 1 dB increase in the output level. For example, a ratio of 4:1 makes the output level increase by 1 dB when there is an increase of up to 4 decibels in the loudness of the input signal. Higher settings of the ratio control let the **COMP76** work more as a limiter than as a compressor, which means that limiting the input level to the bias amount is predominant respective to compressing the input signal dynamics.

The original compressor has the Attack control reversed, with shorter attack times at the full clockwise position. But since it would be an exception respect to all other compressors, we decided to preserve compliance.

OUTPUT - Adjusts the final output level. Once you find the right amount of compression with the Input control, you can use the Output control to compensate any possible gain reduction.

To set the output level press the OUT button and turn the OUTPUT knob as required.

When the ALL setting is selected, a super compression is applied. The attack time gets delayed, so the perceived distortion on transients is significantly increased. Attack and release times, as well as bias levels, do change with this setting, depending on the input signal's shape and level.

REV. - Selects the revision of the original unit to be reproduced.

A is the original revision, whose production was limited to 25 units only, so it was very rare. Revision A of this compressor is the only one to use FETs rather than transistors in the preamp and amp stages. It also didn't have the low noise module as it has been introduced on later revisions, which means that more harmonics are produced by this revision, with a higher level of noise.

D (LN) is the classic and most known revision. It includes the low noise unit which reduces noise and distortion to have a more linear kind of processing.

F is one of the most recent revisions of this compressor, which additionally reduces noise and coloration. This is the best setting to have the original unit compression character with lowest coloration.

IN LEVEL - Adjusts the main Input Level.

STEREO - MID/SIDE - Switches between the two working modes of the **COMP76**. The normal mode is STEREO, where the unit processes the two stereo channels. When in MID/SIDE mode, the stereo signal is split into mid and side portions, where the mid portion is the center, mono part of the stereo image, while the side portion is the outside: the left and right sides of the stereo image. When **COMP76** is in MID/SIDE mode, these two components of the input signal are processed separately. The upper interface, as you can see below the meter, works on MID, while the lower one works on SIDE.

HARMONICS - Adjusts the amount of added harmonics. It ranges from **LINEAR**, which means almost no harmonics, to **DIST**, which is the maximum level allowable. In the middle position there is the original unit level.

LF SENS - Adjusts the frequency of a High Pass Filter controlled by the audio program of the input signal. The filter can reduce the pumping effect when the audio program has a strong low frequency beating component. When set all the way counterclockwise, the filter is turned off.

OUTPUT - Adjusts the Output level to compensate the possible level changes introduced by the compression. It ranges from -15 dB to +15 dB.

PARALLEL - Sets the balance between DRY and COMP (processed) sounds. This is commonly called Parallel Compression.



EQ495

EQ495 is a high fidelity equalizer modeled after one of the best German mixer's channel strip EQ. Its typical usage is as bus or mastering EQ, but it also works very well as an insert effect.



INPUT - Adjusts the level of the input signal.

HIGH PASS - Optionally sets a limit to the lower spectrum of frequencies.

LOW PASS - Optionally sets a limit to the higher spectrum of frequencies.

OUTPUT - Adjusts the level of the output signal. When the **EQ495** settings are cutting away much of the original signal, you can use this to bring the level up again to a normal amount.

BASS Hz - Selects the frequency to attenuate or emphasize.

BASS dB - Adjusts the amount of boost or reduction to apply to the selected bass frequency.

MID Hz - Selects the frequency to attenuate or emphasize.

MID dB - Adjusts the amount of boost or reduction to apply to the selected mid frequency.

MID BANDWIDTH - Selects the mid filter bandwidth from three ranges: narrow, middle and broad.

HIGH Hz - Selects the frequency to attenuate or emphasize.

HIGH dB - Adjusts the amount of boost or reduction to apply to the selected high frequency.

TAPEDESK

TAPEDESK is the modeling of a full analog signal flow using simulations of both professional tape recorder and a console bus.



The graphic interface has three areas: the console input channel on the left side, the tape simulator in the middle, and the console mix bus on the right side. The signal path begins at the input channel, travels through the tape machine, and then ends up at the mix channel. The next chapter includes a diagram and explains why we joined the console channels with a tape machine. But, in a few words, this is the setup necessary to have the most accurately modeled analog reproduction, with the same warm sound you have with real instruments.

You may notice that the console and the tape machine have independent power switches. This means that you can use each component by itself, if you prefer.

TAPEDESK DESIGN

When recording and mixing in the analog domain, the input signal enters into the preamp stage of the console channel, and then is sent to the tape recorder. When the tape is played back, the signal reaches the console again and then is summed in the analog mix bus.

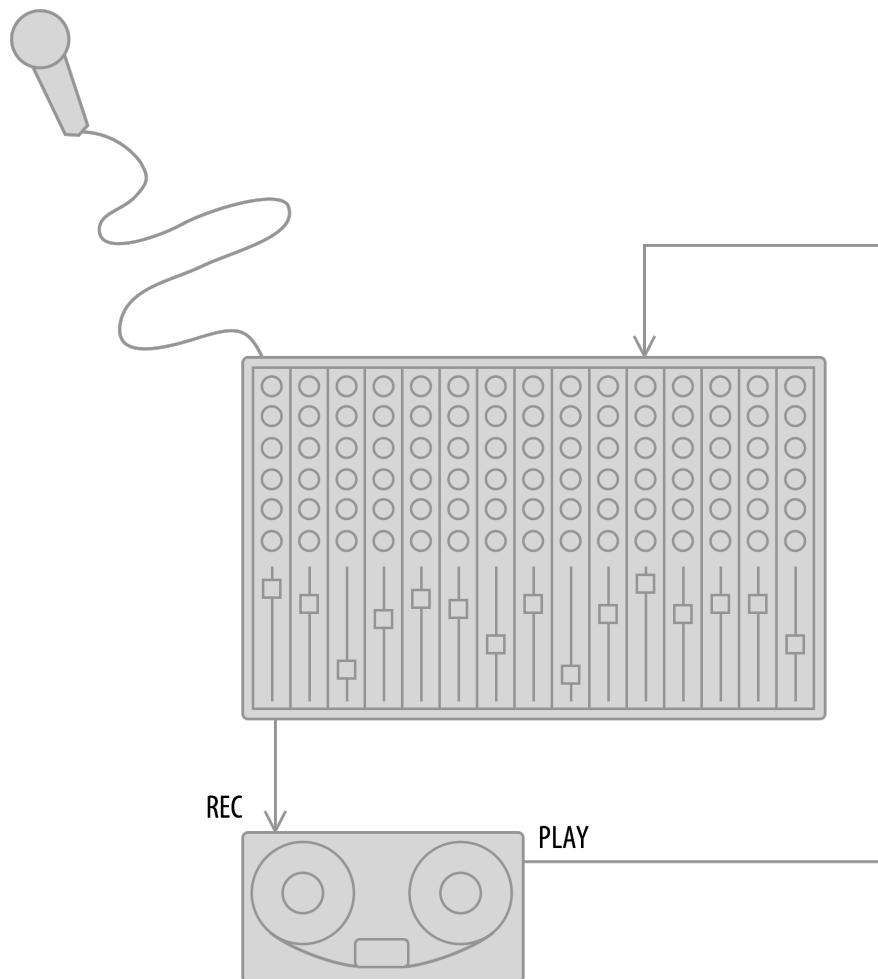

TAPEDESK simulates this complete signal flow in order to recreate the tonal characteristics of the original analog mixing process.

Since in the analog world a tape machine is always physically connected to a console, if you want to replicate the warm tones of an analog mixing workflow, you need to simulate the tape machine, the console, and the interactions between the two. This is what **TAPEDESK** is designed to do.

TAPEDESK uses the best of Overloud's DSP technology to emulate the complete signal path of three different legendary analog consoles: the ones used every day in the last 20 years of audio production to create thousands of hits by the world's finest studios.

The 2-inch 24 track tape machine emulation lets you control any working parameter, from tape speed to biasing, in order to recreate any desired classic analog tone.

Of course in the virtual world of plugins, the sound path described above can be reproduced using many separate plugins strung together as a chain of effects. **TAPEDESK** simplifies all these steps by letting you insert the plugin on your track and enjoying the experience of analog mixing.

TAPEDESK SOUND

The original purpose of the tape recorder was to provide a transparent solution to store and reproduce audio.

But at the time these early tape machines were developed, the latest technology still had specific limitations which greatly influenced the quality of the sound reproduced while playing it back from tape. Tape noise and saturation, modulation noise, harmonic distortion, phase shift and non-linear frequency response are just a few of the examples of how the recorded audio was quite far from the unchanged playback they intended.

For these reasons analog recording was superseded by digital technology.

But, the over-all tape-based recording and reproduction process, with all its intrinsic limitations, conferred a pleasing character to the resulting sound.

If we described the way the sound changed using a few simple words (even with some margin of subjectivity kept in account), we would talk about an increase in the amount and clarity of the harmonic content, as if those frequencies were brought into better focus.

From this perspective, what here in the digital age is generally taken as a quite limited sound processing, has turned out to be quite desirable. Digital audio has been described by many as being cold and wet, while analog processing is considered as sounding warm and musical.

So this is the kind of sound that you can expect from **TAPEDESK** processing. And its parameters do allow ranging from slight sound corrections and trimmings, all the way to dramatic saturation and tape noise. The initial default preset settings provide an accurate and detailed model of all the components of the **TAPE DESK** signal chain.

TAPEDESK IN THE DAILY WORK

One of the most powerful features of **TAPEDESK** is that it is very light on the underlying computer system, so you can feel free to assign it to a sub-mix bus as well as to individual tracks.

Use **TAPEDESK** whenever you need a clearer and warmer sound. Use it with single instruments, ensembles, drum sets and orchestras. And don't forget the mastering stage, where **TAPEDESK** may quickly become indispensable.

TAPEDESK CONTROLS AND PARAMETERS



VU METERS - TAPEDESK has three Meters: two from the mixer and one in the tape machine. All three can be switched between VU or PPM modes.

PPM mode shows peaks because it works with instantaneous levels of the measured signal, so you would expect to see the needle moving a lot while following the waveform of the processed audio. PPM meters are used while adjusting the recording level of an analog machine, so that the audio won't saturate the input stage and let it introduce undesired distortion.

VU mode shows the perceived loudness of the signal, which is a complex but standard and well defined way to show signal levels, focusing more on a kind of "resulting average" level. This setting for a meter reflects more the perceived loudness of measured audio material.

Since both modes are useful in evaluating the characteristics of the processed audio, we support them both.

A last point is about how these digital meters are configured, they are calibrated to show a level of 0 VU when fed by a 1 KHz sine wave with a peak level of -14 dBFS. This is the factory setting for meters. You can change this calibration from the Preferences (see chapter PREFERENCES).

INPUT & MIX - Input trims the signal level on the console bus input channel by also controlling how much the console's typical sound will take part in the audio processing. Mix adjusts the level of the console bus output channel and it works as a level control.

MIC PRE - Enables the mic-pre transformer emulation.

TOLERANCES - Adds a certain amount of drift to the console modeling, to emulate the original's discrete component tolerances. It's important to note that having TAPEDESK loaded in a project with

You can use the tape machine VU meter to control how much you are saturating the tape. The mix VU meter lets you adjust the TAPEDESK output level to keep it close to the input level visible on the input VU meter.

TOLERANCES enabled, that the internal amounts of drift will be preserved when saving and restoring the project.

CONSOLE MODEL - You can switch the console emulation between three available models: S4000, N80, and T88. The features are the same for all, but of course each console has its own characteristic timbre.

S4000 is a very famous mixing console, with a clean, wide and somewhat aggressive kind of character that made it the first choice for high gain rock, metal and pop music.

N80 is another very popular console, with a rich, warm sound which can give your mix some classic vibe.

T88 is a particularly sought-after console, with a thick, fat tone and a renowned personality due to its midrange push.

TAPE SPEED - Three speeds are available: 30, 15 and 7.5 inches per second. Low speed provides better low frequency response, but with some loss in the higher frequencies. Higher speeds response is more full range but with slightly less low end.

REC & PLAYBACK LEVEL - REC LEVEL adjusts the sound level before the virtual recording head, and includes tube circuitry, mic-pre transformer and saturation. PLAYBACK LEVEL adjusts the sound level after the virtual playback head, and includes the effects of tape speed, bias, wow & flutter, and noise (as well as, indirectly, mic-pre transformer modeling and saturation).

BIAS - In the original machine, the bias control was an adjustment which added an ultrasonic signal in order to reduce some limitations of the magnetic heads. This practice has been popularized over the years because adding bias, even at higher ranges, allowed many engineers to get a better sound. The tape machine modeling of **TAPEDESK** provides two settings for bias: NORM for nominal bias and OVER for a +3 dB overbias.

WOW & FLUTTER - These two words describe fluctuations and modulation in the playback speed and frequency response, caused by the mechanical parts of the tape itself. Even if those machines were designed to minimize wow and flutter, these effects have become part of what we refer to when we have to do with an analog tape. Adding more wow & flutter makes the sound rougher and worn.

EQ84

EQ84 is modeled after a masterpiece British EQ of the recent past. It has great character and personality with its biting and aggressive vibe, which gives the sound great clarity and presence.



The graphic interface includes the red input gain knob on the left, then four vertical pairs of black knobs and buttons to control frequencies and bands, and then two blue knobs for high and low pass filters. Finally two more buttons on the right side to switch the EQ section on/off and invert the signal phase.

INPUT GAIN - The red knob controls the input gain using double range: MIC and LINE. Both ranges go from -12 dB to $+12$ dB, but the mic range also adds the modeling of the mic-preamp transformer and saturation.

HIGH SHELF BAND - Adjusts the high frequency with a variable control ranging from 10 kHz to 16 kHz (lower knob), and the level with a variable control ranging from -16 dB to $+16$ dB (upper knob).

The **ON** button enables/disables the high frequency processing, while **CUE** does something almost the opposite, allowing you to sort of "solo", the frequency setting, to hear which frequencies is controlling.

MID BAND 1 - Adjusts one of the two available mid band frequencies with a variable 0.35 kHz to 7.2 kHz control and a variable -16 dB to $+16$ dB control. Here too there are **ON** and **CUE** buttons to enable/disable the mid band and to cue the mid band respectively. **Hi Q** switches the bandwidth of the mid frequency filter using a narrower range when on.

MID BAND 2 - Another mid band, exactly the same as **MID BAND 1**.

LOW SHELF BAND - Adjusts the low frequency with a variable control ranging from 35 Hz to 220 Hz, and the level with a variable control ranging from -16 dB to $+16$ dB. **ON** and **CUE** buttons are present here, too.

The original hardware only allowed fixed preset values for all frequency controls. EQ84 has smooth variable controls instead, with "magnetic snaps" corresponding to the original switch steps. When those "preset" frequencies are selected, the modeling is faithful to the original. EQ84, however, lets you smoothly access all intermediate values as well, to accommodate a far wider range of settings.

HIGH PASS - Sets the high pass frequency from 45 Hz to 360 Hz, cutting off lower frequencies with a 18 dB per octave slope filter. The **BY** button bypasses the filter.

LOW PASS - Sets the low pass frequency from 6 kHz to 18 kHz, cutting off higher frequencies with an 18 dB per octave slope filter. The **BY** button bypasses the filter.

PHASE - Inverts the phase of the output by 180°.

EQL - Includes/excludes the EQ section from the audio processing. When excluded, all EQ filters will be bypassed, but the mic-pre transformer and saturation will still be present (if the Mic range is selected with the input gain control), or if it is set to Line range, it still gives slight color to the processed sound. To completely bypass the plugin you can turn it off with the bypass control on the left corner of the top bar.

OUTPUT - Adjusts the output level ranging from 16 dB to +16 dB with central zero.

DOPAMINE

DOPAMINE is a particular kind of enhancer. It works by taking advantage of a technique originally used in early forms of on magnetic tapes noise reduction, where the tape was encoded by dynamically brightening the signal. Then, while playing back, the tape was decoded by taking off the extra brightness and, consequently, reducing the the tape hiss.

After a while, audio engineers realized that the tape encoding process of these noise reduction units was a desirable effect on certain kind of audio content like vocals, drums and even complete mixes. So they started to use this process in parallel with the original tracks to add liveliness.

This process has been replicated into **DOPAMINE**. The name itself recalls the organic chemical that's used to revive your brain and body because this processor does the same thing to your audio tracks.



MODEL - Two models are available: 361 and 180. Both of them correspond to very popular machines that were used in the “encode only” mode described above to achieve extra brightness.

DRY - Adjusts the amount of unprocessed sound which is transferred to the output.

WET - Adjusts the amount of processed sound which will be mixed with the DRY signal.

COMP - Controls the dynamics of **DOPAMINE** by adjusting the amount of variation, based on the intensity of the input signal.

LEVEL - Adjusts the output level up to ± 15 dB. It is especially useful in A/B comparisons to obtain equal levels.

MODULE CARD (361 only) - The original equipment consisted of a main unit and several special-purpose module cards. **DOPAMINE** modeling includes two of them: the A-TYPE and the NOISE STRESSOR.

A-TYPE is the generic one for standard noise reduction.

NOISE STRESSOR is specially tailored for vocals, as its action is more focused on the mid/low range of frequencies.

EFFECT METER (180 only) - This meter shows in real time how much the processing is adding to the audio, so you can have a visual indication of the amount of effect you are applying to the signal.

WHEN TO USE DOPAMINE

When tracks in your project seem to lack presence and aren't cutting through the mix, or even if they just sound weak, then it's worth trying **DOPAMINE**. You will appreciate how vocals will get extra definition and brilliance, without being overdone.

Basically, **DOPAMINE** is a dynamic equalizer, and the opposite to exciters, as there are no added harmonics. That is the great advantage of this processor: it only uses harmonics that naturally exist in the original tracks. In the opposite manner, exciters generate non-existent harmonics by synthesizing them and often they end up adding unnatural and inharmonic frequencies due to intermodulation.

SCULPTUBE

The **SCULPTUBE** is a processor which adds valve-produced harmonics.

It creates an authentic tube coloration which ranges from slightly warmed-up tones to heavy distortions thanks to its hyper-realistic tube warming and distortion simulation.

You can use the **SCULPTUBE** in many different ways. Three good examples are: Warm-Up, Distort and Excite, which you can obtain as follows:

WARM-UP - With mild Drive settings you can recreate an authentic analog coloration on individual tracks or mixes.

DISTORT - The **SCULPTUBE** can be used to overdrive the input and reproduce different kinds of tube distortions, including Triode and Pentode responses.

EXCITE - Thanks to its built-in EQ and parallel processor you can revive the tracks by adding natural harmonics to the high-end.



OVERDRIVE - Adds 20dB of extra gain to the distortion valve. When switched off the processor produces a gentle saturation: if switched on, highly distorted tones can be obtained.

DRIVE - Controls the amount of gain added to the input signal.

LINK - When **LINK** is switched on, the **DRIVE** and **BIAS** knobs are linked together. In fact, raising the **BIAS** current the **SCULPTUBE** valve reduces its own gain, so it makes sense to compensate this lack of gain by raising the **DRIVE** knob at the same time.

BIAS - Controls the amount of current through the tubes. At lower currents the tubes are under-biased and the sound is inclined to be thinner and breaks up easily. At medium current settings the **SCULPTUBE** distorts least, and this is the typical setting for just warming up a sound. At higher currents the tubes are over-fed and the tone becomes quite fat and harmonically rich.

DISTORTION TYPE P0 (Triode) - Reproduces the typical musical effect obtained with triode valves, with very rich 2nd harmonic distortion. Good for warming up a sound.

DISTORTION TYPE P1 (Pentode) - Pentode type distortion, with prevailing odd harmonics, which make the sound more aggressive while retaining the valve character.

DISTORTION TYPE P2 (Special) - Is obtained with a pretty unusual way of configuring pentode valve, which gives an extra octave at higher bias kind of response.

HIGH PASS - Controls a high pass (low cut) filter after the distortion valve. If set to **OFF**, the high pass filter is bypassed. If set to 1KHz or 4KHz, it cuts the frequencies under the specified frequency with a 6dB/oct rolloff. This filter can be used to keep just the harmonic content generated by the valve and configure the processor as an exciter by mixing these harmonics with the Direct tone.

LOW PASS - Controls a low pass (high cut) filter after the distortion valve. If set to **OFF**, the low pass filter is bypassed. If set to 9KHz or 6KHz, it cuts the frequencies over the specified frequency with

OVERLOUD GEMS

SCULPTUBE

a 12dB/oct rolloff. It can be used to remove some of the extra harmonics of the distortion valve and make the tone warmer.

PARALLEL - Sets the balance between DRY and WET (processed) sounds, and allows to make parallel distortion.

VOLUME - Controls the volume of the output signal.

EQ550

EQ550 is modeled after a renowned American EQ created with custom op-amps. It has become famous thanks to its unique Proportional-Q design, meaning that the bandwidth of the filters becomes narrow when the gain of the filter increases. For low gain settings the EQ delivers a smoother tone: its character becomes more and more aggressive when the bands gain band is raised. This design makes the **EQ550** unique.



INPUT GAIN - This knob controls the input gain. It ranges from -15 dB to $+15$ dB.

HARMONICS - Indicates the amount of harmonics introduced by non linear components of the model like transformers and custom vintage op-amps.

L/F - Low frequency PEAK/SHELF switch. Shelf mode when the button is lit.

LOW BAND - Adjusts the low band frequency ranging from 50 Hz to 400 Hz, and its level with a variable control ranging from -12 dB to $+12$ dB.

The **ON** button enables/disables the band processing, while **CUE** does something almost the opposite, allowing you to sort of “solo” the frequency setting, and hear which frequencies the band is controlling.

MID BAND 1 - Adjusts the first mid band frequency ranging from 400 Hz to 5 kHz, and its level with a variable control ranging from -12 dB to $+12$ dB.

The **ON** button enables/disables the band processing, while **CUE** does something almost the opposite, allowing you to sort of “solo” the frequency setting, and hear which frequencies the band is controlling.

MID BAND 2 - An additional mid band, exactly the same as **MID BAND 1**.

HIGH BAND - Adjusts the high band frequency ranging from 5 kHz to 15 kHz, and its level ranging from -12 dB to $+12$ dB.

The **ON** button enables/disables the band processing, while **CUE** does something almost the opposite, allowing you to sort of “solo” the frequency setting, and hear which frequencies the band is controlling.

H/F - High frequency PEAK/SHELF switch. Shelf mode set when the button is lit.

OUTPUT - Adjusts the output level ranging from -15 dB to $+15$ dB with central zero.

FILTER -50 Hz to 15 kHz band-pass filter.

COMP G

COMP G faithfully reproduces the same dynamic response of one of the legendary compressors which made the story of studio mixing: the G series. This VCA based compressor is a slow rate one, so all transients are preserved and the processed sound keeps its clarity and freshness.

Like the original equipment, this is a master bus compressor, designed to improve the overall sonic quality of a mix, binding its individual components together into a cohesive, professional-sounding whole.

COMP G, as all products of the Gem series, adds some features to the original set. In this case: the MID/SIDE processing, the PARALLEL processing, the HPF filter on the SIDECHAIN and the continuous selection of knobs that, in the original unit, have discrete positions.

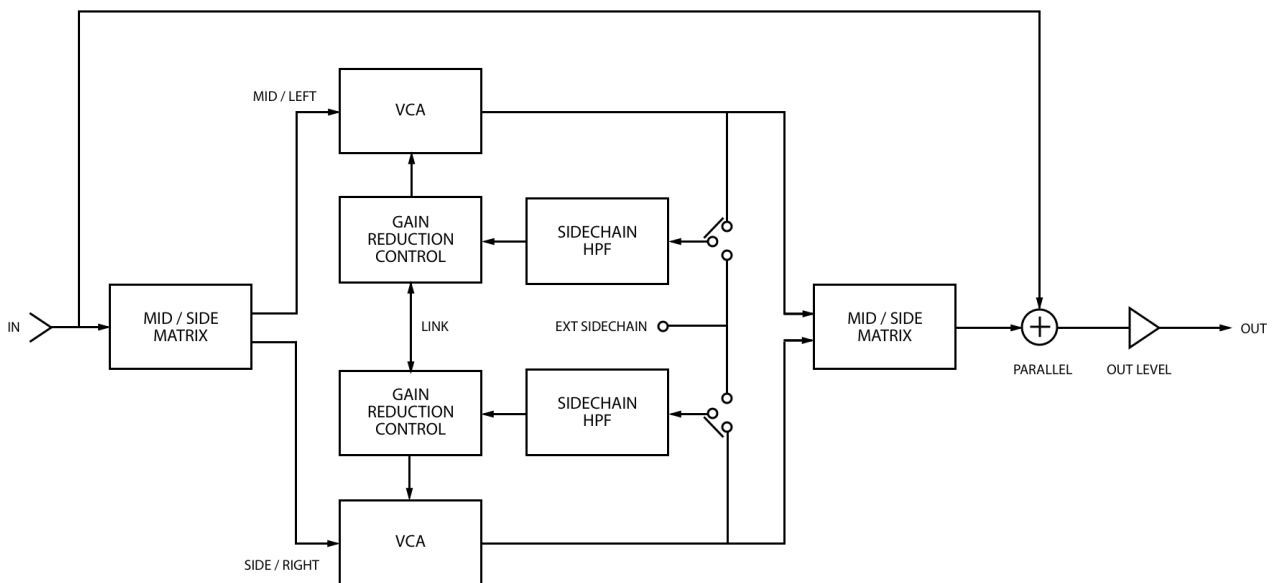

This diagram describes the **COMP G** internal sections and the way they are interconnected.

THRESHOLD - Adjusts the threshold level of the compressor. You can set this value ranging from -15 dB to +15 dB.

ATTACK - Sets the time it takes the **COMP G** to react to a peak of the input signal. The attack time ranges from 100 microseconds to 30 milliseconds with the shortest attack time corresponding to the full counterclockwise position of the knob.

RATIO - Sets the ratio of the signal level to signal gain, also known as the compression rate. It can be continuously adjusted from 2:1 to 10:1.

RELEASE - Sets the time it takes the **COMP G** to return to its no gain reduction state. The release time ranges from 100 milliseconds to 1.2 seconds with the fastest release time corresponding to the full counterclockwise position of the knob. When **Auto** is selected, the release time depends upon the signal program. It's useful to get rid of the pumping effect, when the processed signal has a beating shape.

MAKE-UP - Compensates the signal level changes caused by compression. This parameter can be continuously adjusted from -15 dB to +15 dB.

METER - The meter can alternatively show the Gain Reduction amount, the Input or the Output level.

GAIN - Adjusts the level of the Input signal ranging from -15 dB to +15 dB.

STEREO - MID/SIDE - Switches between the two working modes of the **COMP G**. The normal mode is STEREO, where the unit processes the two, left and right, stereo channels. When in MID/SIDE mode, the stereo signal is split into MID and SIDE portions, where the MID portion is the center, mono part of the stereo image – while the SIDE portion is the outside: the left and right sides of the stereo image. When **COMP G** is in MID/SIDE mode, these two components of the input signal are processed separately. The upper interface works on MID, while the lower one works on SIDE.

SIDECHAIN/HPF - Adjusts the frequency of an High Pass Filter controlled by the audio program of the input signal. The filter can reduce the pumping effect when the audio program has a strong low frequency beating component. When set all the way counterclockwise, the filter is turned off.

PARALLEL - Balances between the DRY (unprocessed) and WET (processed) signals.

OUTPUT - Adjusts the Output level to compensate the possible level changes introduced by the compression. It ranges from -15 dB to +15 dB.

ECHOSON

ECHOSON is the high fidelity reproduction of one of the most popular echo machines of the 1960s. The original unit was manufactured by Binson, an Italian company based in Milan.

The unique signature sound of that echo machine was due to the usage of an analog magnetic drum recorder instead of a tape loop, and to its particular electric circuitry.

The magnetic drum had four record/play heads mounted along an arc of its circumference, and the echo machine allowed the user to select which ones of those heads were recording, and which ones playing. At the output, the processed sound was a variable complex and dense texture of echo reflections with a characteristic timbre for the fading sound decay.

These drum based echo machines have been used with great effect for example by Syd Barrett and David Gilmour from Pink Floyd, on songs like Shine On You Crazy Diamond and Astronomy Domine. But also by Led Zeppelin and Hawkwind, to mention a few.



As done for other Gems, this model goes beyond the original modeled unit features. Some of the differences can be found in the added parameters (see descriptions), but the main difference is the option to double the processor panel to have it working on a stereo pair of audio channels.

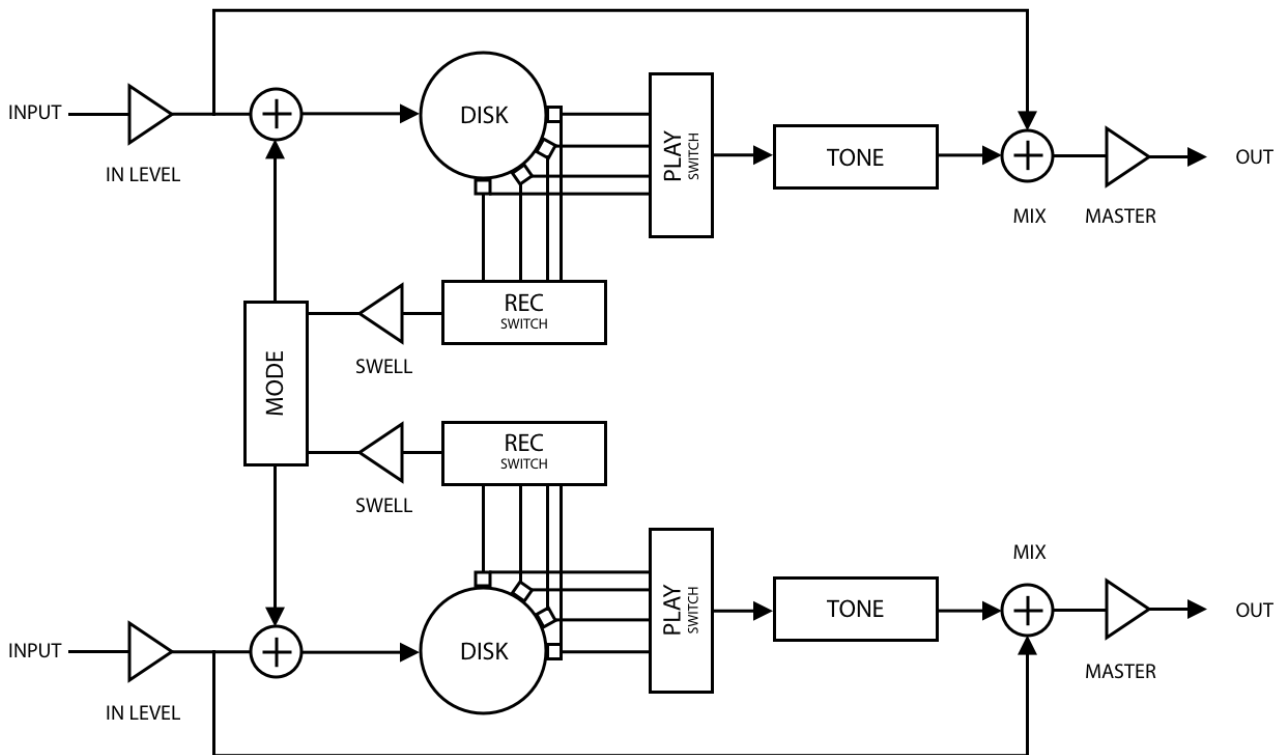

This diagram describes the **ECHOSON** internal sections and the way they are interconnected.

IN LEVEL - Controls the level of the input signal. By increasing this parameter it is possible to push the magnetic disk band up to saturation.

SWELL - Selects the amount of tone fed back to the magnetic disk. It can be used to control the decay of the repetitions. For higher value of this parameter the **ECHOSON** will go into auto-oscillation.

*When the ECHOSON is in STEREO mode, the doubled SWELL parameters can be linked together if the **alt-cmd** key combination (**ctrl-alt** on Windows), is kept pressed while turning one of the two knobs.*

TIME - Selects the delay time of the 4th head (the head with the longest delay). The other 3 heads will change the delay time proportionally. The 12 o'clock position corresponds to the fixed delay time of the original unit, which is approx 310 ms on the 4th head.

MIX - Controls how to blend the direct tone with the output of the delay unit. At 0, only the Dry signal will be on the output. At 5, half of the Dry and half of the Wet will be on the output. At 10, only the Wet will be on the output: this is useful when the delay needs to be added to an aux channel.

TONE - This replicates the original **TONE** control. It allows to decrease and increase the amount of high frequency content on the Wet signal while leaving the Dry sound unaltered.

SELECTOR - Selects the delay repetitions scheme as follows:

ECHO: there is a single repetition for each active PLAY head. No sound is fed back to the disk so there is no swell/reverb effect.

REP: the tone of each active REC head is fed back to the magnetic disk. The tone on each active PLAY head is put on the output. This will generate a "pattern delay" tone with multiple repetition decays over time (at a decay rate dependent on the SWELL parameter).

SWELL: the tone of each active REC head is fed back to the magnetic disk. The tone of all 4 PLAY heads is put on the output regardless of the state of the PLAY buttons. This will generate a reverb-like tone whose decay depends on the SWELL parameter.

REC - Allows to switch on/off each **REC** head individually. The **REC** heads are those which fed the tone back to the magnetic disk, so if only one recording head is activated, the number of delays won't increase over time. If more than one **REC** head are switched on, at each repetition the number of delays (i.e. delay density), will increase over time making the tone more and more similar to a reverb.

The 1st head has a delay time equal to 1/4 of the **TIME** parameter.

The 2nd head has a delay time equal to 1/2 of the **TIME** parameter.

The 3rd head has a delay time equal to 3/4 of the **TIME** parameter.

The 4th head delay time corresponds to the **TIME** parameter.

PLAY - Allows to switch on/off each **PLAY** head individually. The **PLAY** heads are the ones which are sent to the output of the plugin, so this parameter can be used to create repetition patterns.

LINK - If **LINK** is switched on, the **REC** and **PLAY** heads will be set to the same settings, as in the original unit.

TIME OFFSET - Sets the delay time of the right channel proportionally with reference to the left channel's **TIME**.

STEREO MODE - Selects how the repetitions are fed back to the magnetic disks when the unit is in stereo mode.

MONO: left repetitions are only fed back to the left disk and right repetitions are only fed back to the right disk. This is kind of a dual-mono mode, which is like having two separate delay units (one for each input channel) each one with its own settings.

CROSS: the left repetitions are fed back to the right disk and the right repetitions are fed back to the left disk. This can be used to create a kind of ping-pong effect.

VERB: the left and right channel repetitions are mixed together and fed back to both the disks. This will progressively increase the delay density making it similar to a reverb. In order to get the best results from this operating mode it is useful to have slightly different settings on the two channels.

WOW - Controls the amount of wow/flutter effect of the magnetic disk, which is a gentle modulation due to the non-constant rotation speed of the disk. At 12 o'clock the original amount of wow/flutter is replicated.

NOISE - Adjusts the level of electrical and mechanical noise. When set at min, the noise is totally absent, while at max the noise level is a little over the original amount. It's easy to find a satisfying level across the whole parameter range.

EQ - The **ECHOSON** features a 2 band master equalizer which is applied to the Wet signal after the magnetic disk. Each band has the following three controls:

MASTER EQ FREQ: selects the operating frequency of the filter.

MASTER EQ GAIN: selects the gain of the filter. In case of a LPF or HPF filter it controls the filter resonance.

Position	Heads			
	1	2	3	4
1	✓	☐	☐	☐
2	☐	✓	☐	☐
3	☐	☐	✓	☐
4	☐	☐	☐	✓
5	✓	✓	☐	☐
6	☐	✓	✓	☐
7	☐	☐	✓	✓
8	✓	☐	✓	☐
9	☐	✓	☐	✓
10	✓	✓	✓	☐
11	☐	✓	✓	✓
12	✓	✓	✓	✓

This is how the 12 original selector positions correspond to the 4 switch on/off combinations.

MASTER EQ Q: if set at min, the band works as a shelving filter. If set at max, the band works as a LPF/HPF filter. For all the intermediate positions, the band works as a peaking filter.

STEREO - Switches on/off the **ECHOSON** stereo mode. In stereo mode it is possible to have different settings for the left and right channels.

MASTER - Sets the output level of the plugin. It acts both on the Dry and the Wet signal, so it can be used to balance the level of different presets.

COMP670

COMP670 models one of the most popular compressors used in a large number of music productions since its release in 1950. Finding a hardware unit is very difficult nowadays, due to the lack of availability and for the cost which is very high. So this accurate reproduction of the exactly same response of such a compressor comes to a great importance.

Since real units can have slightly different harmonic and dynamic characters, three individual models have been included into this **GEM** coming from units respectively located in: LONDON, LOS ANGELES and MILAN.



STUDIO - Selects the model to use from the three allowable that have been sampled from studios located in LONDON, LOS ANGELES and MILAN. LONDON studio unit has the most transparent tone. LA one is a little smoother and has a bigger overall compression amount. MILAN unit has larger harmonic generation due to some non original spare parts used to repair it.

INPUT GAIN - Controls the volume of the input signal. Level 14 corresponds to 0 dB. Turning the knob clockwise the amount of compression will raise.

THRESHOLD - Adjusts the amount of compression.

TIME CONSTANT - Controls the Attack and Release time lengths.

AGC - Selects the Automatic Gain Control mode.

LEFT/RIGHT: The compressor works as two separate compressors with individual controls per channel.

LAT/VERT: Stereo signal is split by a sum/difference matrix into sum (upper/left channel) and difference (lower/right channel). The input signal level is controlled after the matrix, so the relation between sum and difference channels can be controlled. At the compressor output, there is a second matrix which turns it back into a stereo signal.

METERING - Meters can be set to display Gain Reduction, Input, Output or Harmonic generation levels.

LINK - All **LINK** switches optionally connect equivalent controls present on LEFT/RIGHT or LAT/VERT channels.



The chain button on the top bar can be used to turn all links ON or OFF at once.

DC THRESHOLD - This control is a small trimmer inside the compressor unit, to be adjusted with a screwdriver. It changes the compression curve, from soft-knee to hard-knee.

HARM - Adjusts the amount of non linear processing, which turns into adding harmonics to enrich the processed signal.

OUTPUT - Controls the level of the two channels after the compression. Can be used as a make-up gain. In LAT/VERT mode it can increase or reduce the stereo image in proportion to the mono image.

SIDECHAIN FILTER - Additional high pass filter on the sidechain which makes the compression less sensitive to bass frequencies. This is useful to reduce the pumping effect if the processed signal has much bass frequencies.

PARALLEL - Mixes **DRY** and **WET** signals creating a parallel compression effect.

OUTPUT - Controls the overall output level.

STEREO LINK - When set in LEFT/RIGHT mode, the compressor works as two independent mono compressor units. This **PREFERENCE** optionally links both compressors together.

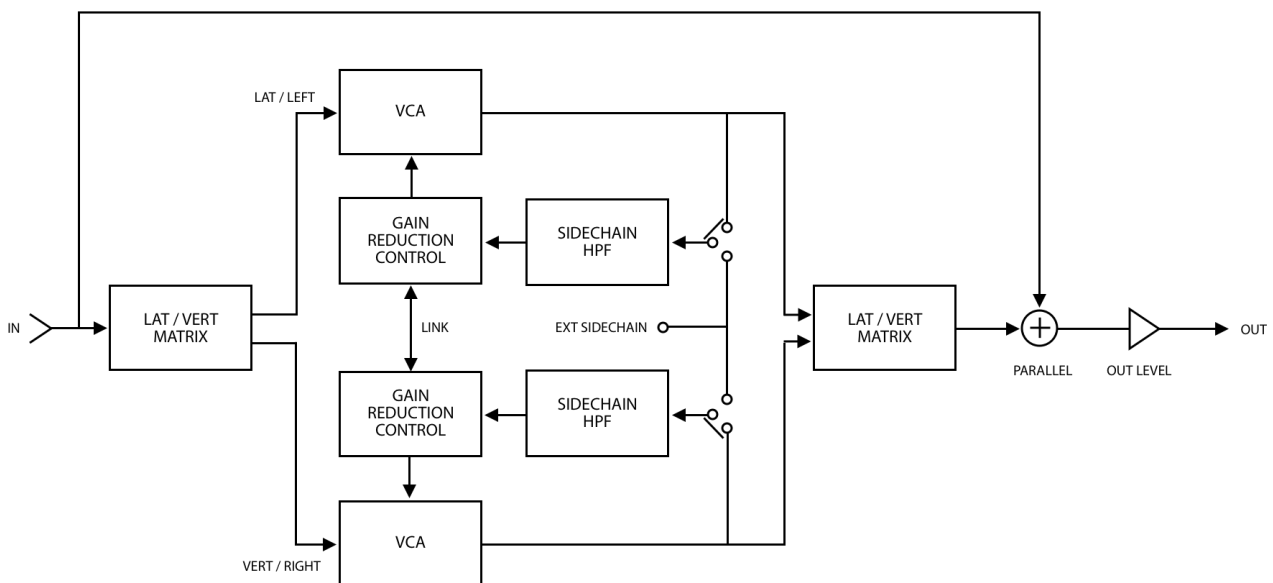
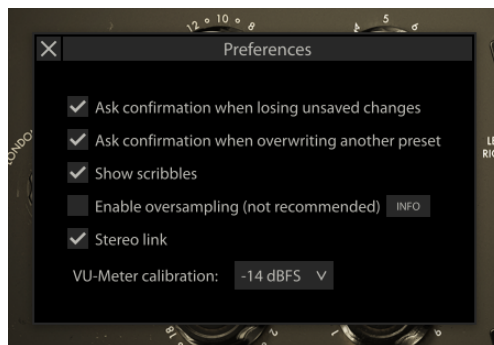

*This diagram describes the **COMP670** internal sections and the way they are interconnected.*

OTD-2

OTD-2: can be seen at same time as a modulation effect and as a traditional delay unit. By using short delay times, you can achieve the effect of widening the source sound by duplicating it with some inharmonic delays. This technique also can be used to add weight and body to your flanged sound, as flanger units usually tend to make the processed sound lighter.

When longer delay times are set, making a shrewd usage of programmable tap echoes, you can improve the depth and width of the input signal, and thanks to the internal feedback path, the resulting sound will be amazingly textured with musical harmonics. Additionally you can modulate the delay lines in order to achieve chorusing and sound widening effects.



INPUT LEVEL - Controls the level of the **INPUT** signal.

INPUT MONO/STEREO - Selects how the **OTD-2** works when it gets inserted on a STEREO track. When set to STEREO, the input pair of signals is kept and processed as is, while when set to MONO, the input channels are merged together (as it happens on the real hardware) before being processed. When the **OTD-2** is instantiated on a MONO track, this selector has no alternatives to select.

OUTPUT DRY L/R - Controls the separate (left / right) levels of the DRY (unprocessed) signal.

OUTPUT WET L/R - Controls the separate (left / right) levels of the WET (processed) signal.

OUTPUT LEVEL - the level of the **OUTPUT** signal.

OUTPUT AGE - The original circuit was based on a so called "bucket-brigade" device, an electrical component which created delay in the analog domain. Bucket-brigades add a lot of color to the sound and are responsible for the distinct tone of this processor. With the **AGE** knob you can control the amount of coloration: the middle position corresponds to the original device amount. You can even increase more, or just decrease it and let the effect sound closer to a modern digital delay processor, while still keeping the creative delay tapping and modulation features.

TAP ASSIGN - The **TAP ASSIGN** section has been greatly improved from the original one. There are 6 taps for each channel of the stereo pair. Every tap switch can be used to route the corresponding tap on the left or right side of the resulting stereo image. And the squared lit buttons close to them, turn the taps on or off. The original device only works with mono input signals while **OTD-2** is able to even process stereo ones. So the stereo version of the TAP ASSIGN section has twice the original controls.

Tap delay times, in milliseconds, are as follows (ranges depend on the FIXED knob value):

The input meter is calibrated such that the 0dB indicates that the bucket-brigade circuit is starting to saturate.

If you press alt-cmd (alt-ctrl on Windows) while you move the INPUT LEVEL or OUTPUT LEVEL controls, these two knobs will move coupled so that the resulting signal will stay at the same level.

TAP	STANDARD RANGE (ms)	WIDE RANGE (ms)
1	2 - 8	46 - 226
2	3 - 14	82 - 408
3	5 - 23	136 - 678
4	6 - 32	190 - 948
5	9 - 46	279 - 1393
6	11 - 55	333 - 1665

As in the original unit, tap delay times have inharmonic intervals between each other. This is useful when you are searching for a reverb like kind of delay effect. The **OTD-2** processor allows to control the amount of inharmonicity with the **QUANTIZE** knob. The **ORIGINAL** position corresponds to the original device settings, while the **EVEN** position is where the taps are equidistant one from each other with the result of having a more digital kind of delay effect. You can continuously range between these two settings to find the sound that fits your need.

As for other Gems, the LINK option allows to keep two controls connected together, and to move one to set them both. In the TAP assign section, controls are grouped in rows, and activating the LINK option, when you move a switch on one column, the corresponding switch on the other column will follow the same move accordingly. And the same happens with the lit tap power buttons.

REGENERATION IN/OUT - When ON, the signal of one or more taps, depending on the status of **STEREO MODE**, is fed back to the input stage.

REGENERATION LEVEL - Controls the amount of signal fed back to the input.

REGENERATION HI CUT - Filters away some high frequency content from the signal fed back to the input.

REGENERATION TAP - Selects the tap as source for the regeneration signal. This is meaningful when the **STEREO MODE** is set to **MONO** which is how the original unit works.

REGENERATION STEREO MODE - Selects how the regeneration works.

MONO is the way the original unit works, letting a single tap signal to be fed back to the input. The tap to feed is selected by the **REGENERATION TAP** control.

CROSS is a new mode, and works almost the same. In addition it swaps the stereo channels while feeding them back to the input. This will make the processed sound more mixed by also balancing the stereo image.

VERB is a special new mode, where all active taps are fed back to the input at same time. The point of this mode is to overlap the taps to obtain a very dense reverb like delay effect (**QUANTIZE** set to **ORIGINAL**), or even to emphasize the distinct tap individual echoes to have rhythmic patterns (**QUANTIZE** set to **EVEN**).

DELAY MODE - Selects the way the delay manages time.

STANDARD is the original setting, with standard 1x to 5x range for tap delays.

WIDE makes the whole time base wider by multiplying the times by a 30x factor. This lets you completely reinterpret the usage of the **OTD-2** bringing it closer to a traditional delay unit, by still keeping other cool features available.

SYNC allows you to synchronize the delay time with the host tempo. Very useful when you want the tap regenerated beats to play in time with the song you are processing. Or even if you basically just need to let the effect follow song's tempo changes. Once you selected **SYNC**, you can choose the tempo division clicking the current notation.

DELAY FIXED - Adjusts the fixed portion (excluding modulations) of the delay time for the taps. When the knob is fully CCW, time is the longest possible. When the knob is fully CW, time is shortest. The time set by this parameter is also influenced by the state of **DELAY MODE**.

DELAY MIX - Adjusts the amount of LFO modulation (called **SWEEP**) to the delay times.

DELAY SWEEP - Sets the speed of the oscillating **SWEEP** signal which modulates the **FIXED** delay time. You can range from slower speeds to have chorus like effects, to faster speeds to have Leslie or vibrato effects.

DELAY SWEEP MOD - When turned on, the **SWEEP MOD** modulates the SWEEP signal with an oscillator running at a slightly higher frequency, to obtain kind of random sweeps which turn into very rich and fat chorus effect. When the knob is all the way left, this modulation is disabled.

Transistors, on the other hand, can switch to high powers faster, so the 3A units had shorter attack times and sounded more neutral and modern, by adding less harmonic distortion.

COMP LA faithfully reproduces both models and additionally allows to control the amount of added harmonics.

LIMIT / COMPRESS - Changes the character of the compressor unit switching between a soften action with lower compression ratio, for the **COMPRESS** position, and a higher compression ratio with damped attack transients when set to the **LIMIT** position.

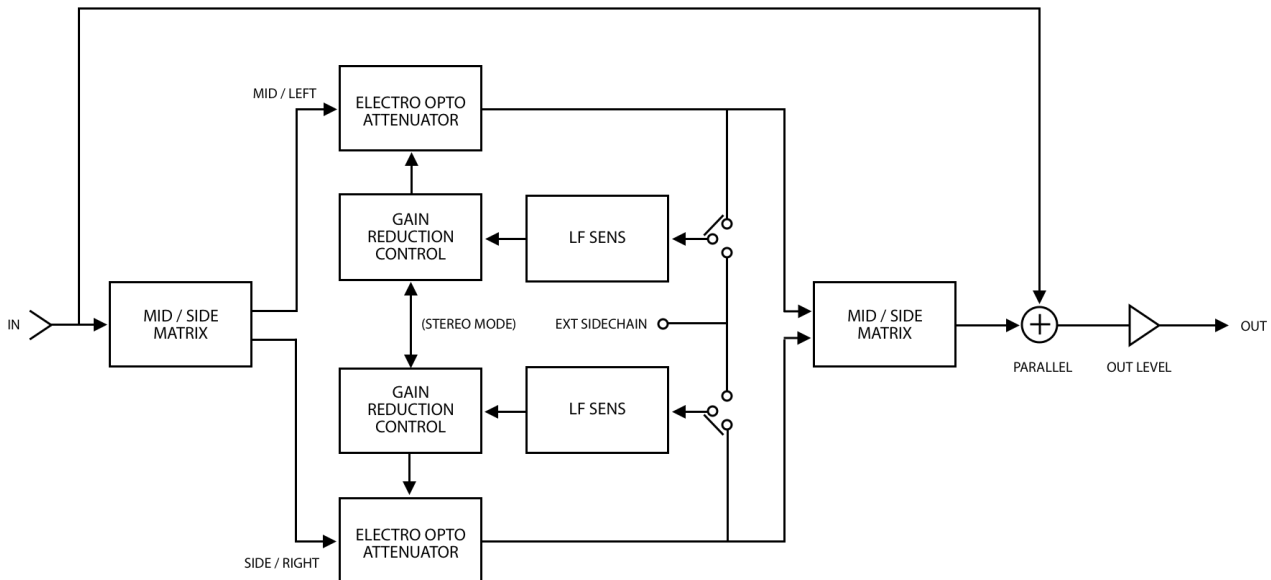

This diagram describes the **COMP LA** internal sections and the way they are interconnected.

GAIN - The **GAIN** control does not affect the amount and quality of the compression. Its action applies at the final stage of the compressor unit, more like a level control. By the way, when the **COMP LA** is set to **MID-SIDE** mode, and two different compression rates are applied to two parts of the input signal, both levels can be adjusted independently with the relative **GAIN** controls.

VU-METER - The VU-Meter can be used to see 4 different measures: Input Level, Gain-Reduction, Output Level and the amount of Harmonics added by the processor.

PEAK REDUCTION - Adjusts the amount of compression to apply to the input signal by specifying how much the peaks need to be reduced. A good way to operate is to first find a good setting for this control and next to adjust the **GAIN** level.

TUBE (2A) / SOLID STATE (3A) - Selects the original compressor model. 2A is a tube based compressor while 3A is conceptually the same unit but working with transistors. **TUBE** provides slower compression attack, mid range prominent frequencies and more harmonics, while **SOLID STATE** gives faster compression attack, a sort of "U" shaped frequency response and less harmonics.

IN LEVEL - Controls the input level. It ranges from -15 dB to +15 dB.

STEREO / MID-SIDE - Switches between the two working modes of the **COMP LA**. The normal mode is **STEREO**, where the unit processes the two, left and right, stereo channels. When in **MID/SIDE** mode, the stereo signal is split into **MID** and **SIDE** portions. **MID** portion is the center, mono part of the stereo image – while the **SIDE** portion is the outside: the left and right sides of the stereo image. When **COMP LA** is in **MID/SIDE** mode, these two components of the input signal are processed separately. The upper interface works on **MID**, while the lower one works on **SIDE**.



Here is how both units look when they are set to MID-SIDE mode.

HARMONICS - Adjusts the amount of added harmonics. It ranges from **LINEAR**, which means no harmonics at all, to **DIST**, which is the maximum level allowable. In the middle position there is the **ORIGINAL** gear level.

LF SENS - Adjusts the frequency of a High Pass Filter controlled by the audio program of the input signal. The filter can reduce the pumping effect when the audio program has a strong low frequency beating component. When set all the way counterclockwise, the filter is turned off.

PARALLEL - Balances between the DRY (unprocessed) and WET (processed) signals.

OUTPUT - Adjusts the Output level to compensate the possible level changes introduced by the compression. It ranges from -15 dB to +15 dB.

VOICE

VOICE: includes the modules for the complete processing of a vocal track.

The **Gem VOICE** includes 8 modules: Mic Preamp, Tape Sim, Enhancer, Multiband containing a De-Boxer and a De-Esser, Compressor, Equalizer, Space and Delay, plus the Master section with a Limiter.

Each module has a list of models from which you can select its character. Most of the listed models are references to real hardware. Others are typical responses to specific kinds of analog processing. This high degree of flexibility lets the **VOICE** fit in every mixing context easily and make voice processing very effective.



MIC PREAMP

This module models a real mic preamplifier enriching the input sound with the renowned harmonics of the selected model.

MODEL - Selects the model emulated by the Mic Preamp module.

GAIN - Adjusts the gain of the module by also impressing the character of the selected model in terms of harmonics added by the mic preamp transformer and saturation.

CUT - Cuts lower frequencies. Useful when the harmonic content is unbalanced towards the low frequencies.

PHASE - Inverts the input signal.

LEVEL - Each module of the **VOICE** includes a -15 / -15 dB level control, which allows gain staging of all the modules in the sound chain.

LEVEL METER - Close to the LEVEL controls, you can find the corresponding LEVEL METER which shows the current level of the signal emitted by the module. Act on the LEVEL control to keep the level the higher possible below the red peak levels.

ON (POWER) / S (SOLO) - Each module of the **VOICE** also includes POWER and SOLO controls to temporarily esclude (bypass) a module from the processing and to temporarily exclude all powered modules (SOLO). It's a fast way to evaluate how each module participates to the whole sound.

TAPE SIM

This module reproduces the typical tape recording harmonic distortion. The processed sound gets some color from this module, which generally corresponds to an analog kind of timbre.

DRIVE - Adjust the gain of the signal recorded on the tape: it allows to control the amount of saturation. The same control compensate the increased recording level by lowering the playback level.

BLEND - Adjusts the mix between the input and the processed signal.

ENHANCER

When the voice recording seems to lack presence and isn't cutting through the mix, or even if it just sounds weak, then it's worth adding some amount to the ENHANCER. You will appreciate how vocals will get extra definition and brilliance, without being overdone. The ENHANCER only uses harmonics that naturally exist in the original tracks. In the opposite manner, exciters generate non-existent harmonics by synthesizing them, and often they end up adding unnatural and inharmonic frequencies due to intermodulation.

AMOUNT - Adjusts the amount of effect added to the processed signal.

MULTIBAND

This module is a specific double filter to attenuate voice artefacts from mic recordings. Both filters work as compressors.

The DE-BOX is a dynamic control of the lower-mid part of the frequency spectrum. Boxy vocals contain too much low frequency energy and lack the proper excitement needed to cut through the mix. The DE-BOX processor dynamically removes this low-mid excess.

The DE-ESSER focuses on sibilant sounds letting you to control their prominence.

You can control both filter amounts while looking at the gain reduction meter just close to the knobs.

DE-BOX AMOUNT - Adjusts the amount of DE-BOX filter applied.

DE-BOX FREQ - Adjusts the frequency around which the DE-BOXing works.

DE-ESSER AMOUNT - Adjusts the amount of DE-ESSER filter applied.

DE-ESSER FREQ - Adjusts the frequency around which the DE-BOXing works.

AUTO CUE - Automatically puts the DE-BOX or the DE-ESSER filter in solo while you drag one of its knobs. This allows you to listen the frequencies that the filters are processing.

SWAP POSITION - On the top of the module, there is a white triangular button which can be found on the EQUALIZER module too. You can click this button to move the EQUALIZER before the MULTIBAND and have their contribution intervening in the wanted point of the processing.

COMPRESSOR

This module can be used when you need to control the voice dynamic variations.

COMP - Adjusts the amount of dynamic compression. This is internally done by lowering the threshold or raising the input gain, depending on the selected Model

TIME - Adjusts the time constants of the compressor. When you increase time, the Release time is increased and the Attack time is decreased, an viceversa.

EXP GATE - Adjusts the threshold of an expander gate, under which the input signal is reduced to clean it from unwanted noise.

LF SENS - Adjusts the frequency of a High Pass Filter controlled by the audio program of the input signal. The filter can reduce the compressor sensitivity to the lower vocal frequencies. When set all the way counterclockwise, the filter is turned off.

EQUALIZER

Using the EQUALIZER you can adjust the harmonic content of the input signal. Useful when the starting material has prominence or leakage of a range of frequencies. Or either when other modules processing change the harmonic content by emphasising or filtering out a frequency range. Three bands are available, plus an optional SUB CUT control.

LOW GAIN - Adjusts the gain of the LOW frequencies.

LOW FREQ - Selects the LOW band frequency.

MID GAIN - Adjusts the gain of the MID frequencies.

MID FREQ - Selects the MID band frequency.

HIGH GAIN - Adjusts the gain of the HIGH frequencies.

HIGH FREQ - Selects the HIGH band frequency.

SUB FREQ - Selects the SUB CUT frequency.

CUT - Switches ON/OFF the SUB CUT filter.

The EQUALIZER can work from two different positions in the modules sequence. This feature allows to have the harmonic content adjusted before or after the MULTIBAND / COMPRESSOR modules, which are those that mainly shape the signal dynamics.

To move the EQUALIZER module to its alternative position, just click the small white triangular button on its caption.

SPACE

SPACE is a multidimensional processor allowing to create or enhance the dimension and placement of a voice in the mix.

AMOUNT - Adjusts the amount of reverb to add.

REV TIME - Adjusts the reverb time. Enabled when the SPACE model is a long tail reverb.

STONE - Adjusts the harmonic balance (color) of the reverb.

WIDE - Adjusts the wideness (stereo aperture) of the reverb.

DEPTH - Adjusts the predelay time which, on very short impulses, changes the perceived depth of the recreated ambience.

DELAY

This module creates a warm stereo delay, designed as a replacement of long reverbs according to the most recent mixing trends. You can use this effect with short times to add room early reflections, or with mid times to improve the SPACE environment effect. Using uncorrelated delay times allows to add an extra depth to the recreated space.

MIX - Adjusts the balance between dry (direct) and wet (processed) signal.

TIME - Adjusts the delay time. You optionally can turn the BPM sync on clicking the note button close to the TIME control, and use the knob to select the wanted BPM synced division.

DISPLAY

This graphic display shows has two views: EQ and COMP, showing EQUALIZER and COMPRESSOR curves respectively.

You can switch the view with the EQ and COMP buttons, or select AUTO to have the views switched automatically when you move the mouse cursor over one of the involved modules. This is particularly useful when you are searching for a balance between both modules action, 'cause you don't have to continuously switch view manually.

EQ - When the EQ view is selected, two curves are drawn. The spectral content, which is the real time moving filled area showing the amounts of all frequencies, and the filter curve which describes how the EQUALIZER module is intervening on the harmonic content to adjust it.

When the EQ view is selected, the filter curve is shown with 4 colored interactive circles. The circle colors correspond to the EQ band knob colors. You can drag the circles to adjust the equalization (the EQ knobs will move accordingly) and evaluate the processing in real time. This feature lets you edit the EQ curve right where it needs to.

COMP - When the COMP view is selected, you can see the level curve on the lower side, and the COMPRESSOR gain reduction level on the top side. This way you can easily correlate how the compression is responding to the level peaks. The more compression you ask for, the more the gain reduction "inverse" peak will counterbalance the level peaks.

MASTER

The last module of the **GEM VOICE** is the MASTER which includes two sections: LIMITER and OUTPUT.

LIMITER - Adjusts the amount of output limiter, which allows to control peaks without clipping them. The limiter threshold is always 0dBFS and no samples will go over the 0dBFS if the limiter is switched on.

MONO / STEREO - Selects the kind of output: stereo or mono.

OUTPUT LEVEL - The two master faders adjust the final output level, after the limiter action.

LINK - Optionally links the output faders together.

OVERLOUD GEMS

MODULA

The Overloud **GEM MODULA** includes a set of three models of iconic vintage modulation effect units.



On the bottom side of the window is the master panel with three buttons to select the modulation unit, and a set of controls to adjust the processed sound.

With the **DUAL** button, only active when the plugin is working on a stereo signal, the master panel also allows to double the modulation unit letting both instances to process the left and right channels individually.

If you alt-click DUAL, the parameter settings of the active panel get copied to the second panel. This is useful when you want to process a stereo signal starting from a perfect duplication of the same processing for both channels.

DIMENSION

MODE - The **DIMENSION** unit replicates a very popular modulation unit which originally only worked by selecting the unit mode, from 1 to 4. Modes were implemented as presets for the whole unit. The idea behind the **GEMS** product

If you alt-click the MODE buttons, you can activate more than one mode and experiment new modes for the modulation.

OVERLOUD GEMS

product line is to go beyond the modeled units providing more parameters and improving parameter ranges.

Therefore, the **DIMENSION** modulation can be finely controlled by the four parameters: **SPEED**, **DEPTH**, **SHAPE** and **AMOUNT**. And furthermore, for three of those parameters, **SPEED**, **DEPTH** and **AMOUNT**, the **ENV** control is available to modify the parameter value according to the envelope of the input signal.

SPEED - Adjusts speed of the modulation. The range of this parameter is from 2.00 Hz to 10.0 Hz. The speed can be set manually (keep **SHIFT** pressed for fine tuning), or either be synced with the DAW tempo.

SYNC - Enables or disables the DAW tempo synchronization. When the **SYNC** is on, the speed is selected from a set of time divisions. In this case, the speed will follow any song bpm change.

SYNC ENV - Adjusts the amount of positive or negative change to the sync value according to the input signal envelope. Useful when you want to add some randomness to the modulation speed.

ENV faders include meters that show how much they are affecting the parameters they relate to. When you move the cursor over an ENV fader, all faders become transparent (you can use this feature to see meters with no obstacles).

DEPTH - Adjusts depth (amount) of modulation. The range of this parameter is from 0% to 100%.

DEPTH ENV - Adjusts the amount of positive or negative change to the depth value according to the input signal envelope. Can be used to control the amount of modulation corresponding to louder or weaker input signals.

SHAPE - Changes the shape of the LFO respect to the original shape. Can be used to vary the timbre of the modulation.

AMOUNT - Adjusts the amount of Wet (processed) signal to be transferred to the output sound. The range of this parameter is from 0% to 100%.

AMOUNT ENV - Adjusts the amount of positive or negative change to the amount value according to the input signal envelope.

VU METER - Displays the real time value of the output signal level.

The following diagram shows the internal processing scheme of the Modula.

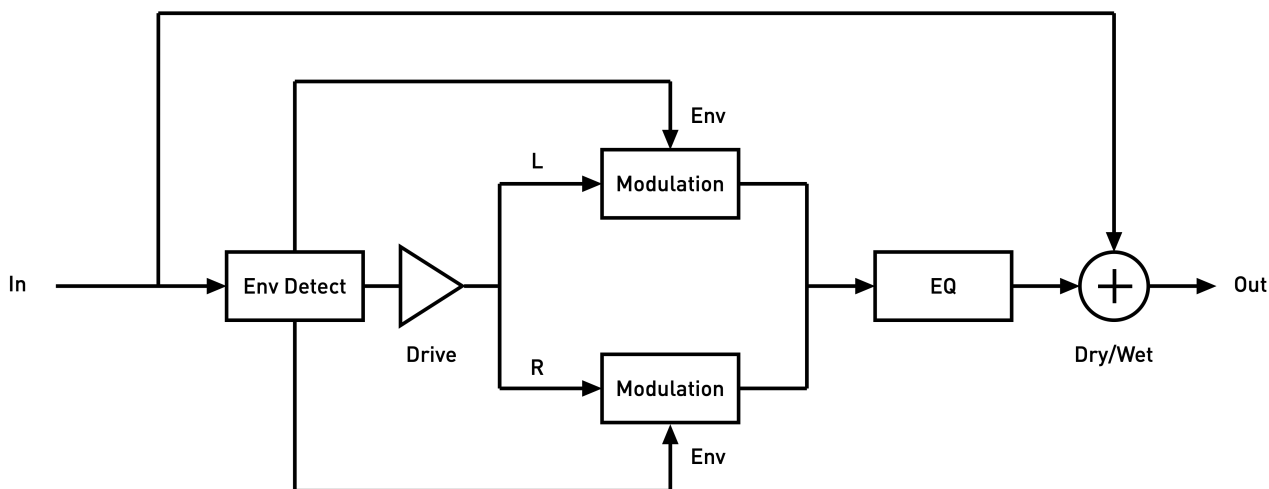

OVERLOUD GEMS

ENSEMBLE

The **ENSEMBLE** unit replicates the modulation stage of a vintage instrument which originally only could be turned on or off with a switch button. Following the **GEMS** philosophy, the original modulation processing can be customized by adjusting Modula parameters.

For a description of all **ENSEMBLE** parameters you can refer to the **DIMENSION** ones described above.

SYMPHONIC

The **SYMPHONIC** unit replicates the processing of a modulation preset inside a popular and very appreciated Japanese vintage analog-digital multi effect unit. The Symphonic preset of the original unit sounded like a flanger by modulating the input signal with its LFO. This kind of modulation is particularly suitable for keyboard instruments whose sound gets thicken and waving with the added pitch and stereo imaging variations.

MASTER

The **MASTER** section includes controls to select the model of the modulation: **DIMENSION**, **ENSEMBLE**, **SYMPHONIC**. And other controls to finalize the processed sound.



IN LEVEL - Adjusts the level of the input signal.

EQ GAIN 1 - Adjusts the gain of the EQ band 1 frequency.

EQ FREQ 1 - Selects the frequency of the EQ band 1.

EQ Q 1 - Adjusts the Q of the EQ band 1.

EQ GAIN 2 - Adjusts the gain of the EQ band 2 frequency.

EQ FREQ 2 - Selects the frequency of the EQ band 2.

EQ Q 2 - Adjusts the Q of the EQ band 2.

EQ - Turns the EQ on / off (bypass).

LFO - Adjusts the randomness of the LFO. Can be used to reduce the typical effect of cyclicity perceived when LFOs are used.

DUAL - Doubles the modulation panel to have both processing the stereo channels individually.

STEREO WIDTH - Controls the stereo image aperture by narrowing (turn left) or widening (turn right) the stereo channels separation.

MIX - Adjusts the mix between **DRY** (input) and **WET** (processed) signals.

OUT LEVEL - Adjusts the level of the output signal.

OVERLOUD GEMS

LINKS

The **MODULA** toolbar includes the LINK button.

Clicking the LINK button, a popup panel will appear, showing the parameters that can be linked together when the **MODULA** is in DUAL mode.

Parameters which are linked are set to the same value at first change after linking. Next, they will move coupled.

The LINK button on the toolbar turns red when there are active links.



OVERLOUD GEMS

MOD

The Overloud **GEM MOD** is a free **GEM**. It includes the **DIMENSION** panel of the **GEM MODULA**, and can be installed and ran for free, to let everybody taste the quality of the **MODULA** modulation modeling.

You can refer to the above **MODULA** chapter for **MOD** features descriptions.



EQP

The Overloud **GEM EQP** is the faithful modelling of a legendary EQ unit that has been widely used on a huge number of recordings from the 50s to today. The most appreciated feature of this unit is its capability of enhancing certain frequencies without significantly altering neighbouring ones. This unit is able to work with extreme settings without losing its particular vintage tone and can be used as a simple pass-through to easily improve the processed sound.



IN LEVEL - Adjusts the level of the input signal. Range is ± 15 dB.

OUT LEVEL - Adjusts the gain of the output signal. Range is ± 15 dB.

GRAPHIC CURVE - Shows the current EQ curve. Amplitude range is ± 18 dB while the Frequency range is 20 to 20 kHz.

CLIPPER - The **Gem EQP** adds a Clipper unit to the output of the original processor. The Clipper is a useful addition when mixing drums, percussions and, in general, tracks with transients, to add punch and definition. The Clipper knob adjusts the saturation threshold. You can see the amount of clipping by looking at the blue light turning to red. The range of the control is -12 dB to 0 dB. You can switch the clipper off by turning the knob all the way right.

OVERLOUD GEMS

MID MODULE

The **MID** module controls three frequency bands: low, mid and high, allowing to add and control colors to the richer part of the harmonic spectrum.



MID ENABLE - Turns the **MID** module on/off. Not being a true bypass control, the **MID** module still adds some color to the processed sound even when set to off. A whole true bypass can be obtained by the red button on the left side of the Gem toolbar.

MID LEVEL - Adjusts the level of the **MID** module processed sound. Range is ± 12 dB.

LOW PEAK (FREQ+BOOST) - Adjusts the low band of the EQ. Frequency selector ranges from 200 Hz to 1 kHz. The **BOOST** control adds up to 12 dB to the selected frequency.

DIP (FREQ+ATTEN) - Adjusts the mid band of the EQ. Frequency selector ranges from 200 Hz to 7 kHz. The **ATTEN** control subtracts up to 12 dB to the selected frequency.

HIGH PEAK (FREQ+BOOST) - Adjusts the high band of the EQ. Frequency selector ranges from 1.5 to 5 kHz. The **BOOST** control adds up to 12 dB to the selected frequency.

EQP MODULE

The **EQP** module is where the heart of the original EQ unit resides. The module includes four regions. First comes the power and level controls, then the low frequency controls, then the high frequency controls and finally the cutoff controls.



EQP ENABLE - Turns the **EQP** module on/off.

EQP LEVEL - Adjusts the level of the **EQP** module processed sound. Range is ± 12 dB.

LOW FREQUENCY - Selects the frequency of the low band. Available values are 20, 30, 60 and 100 (the "CPS" label stands for "cycles per second" also known as Hz). **BOOST** and **ATTEN** controls apply to the selected frequency.

HIGH FREQUENCY - Selects the frequency of the high band. Available values are 3, 4, 5, 8, 10, 12 and 16 (the "KCS" label stands for "kilo cycles per second" also known as kHz). **BOOST** and **BANDWIDTH** controls apply to the selected frequency. The attenuation controls work together. **ATTEN SEL** selects the frequency: 5, 10 or 20 kHz. **ATTEN** adjusts the amount of attenuation for the selected frequency.

OVERLOUD GEMS

CUT OFF - The final stage of the **EQP MODULE** is where frequencies can be cut off. **HIGH CUT** for high frequency, with a final position to disable the high cut. **LOW CUT** for low frequency with an initial off position to disable the low cut. This stage too includes an enable switch.

OVERLOUD GEMS

SOLO

When you are in MID-SIDE mode, you can listen to one of the two components with the solo function. To put MID or SIDE part in solo, move the mouse cursor over the MAKE-UP control you want to solo and locate the popup “S” button after it pops up and click it. The SOLO button will turn to yellow and the selected component will play in solo. You can do the same with the other MID-SIDE component as well.



Comp G interface showing the SOLO buttons with the MID portion playing in solo.

Gems supporting the solo function are:

- **Comp76**
- **Comp G**
- **Comp670**
- **Comp LA**

SCRIBBLES

In the real world, when you operate on multiple machines with several channel strips, panels and control surfaces, you can have the need to note things around, adding labels, tape bends, describing what is where, so that you can easily recognise them while doing your work.

In a computer's display something similar can easily happen when your project turns into something bigger than as usual, with more and more windows of instances of plugins overlapped all around the screen.

Since the Gems are reproductions of real gears, we decided to add them the support for labels, that we have called Scribbles.

Scribbles can be stuck to Gem interfaces very easily. Just select Add Scribble from the popup menu that you'll see by clicking the button on the right side of the menu bar. A new Scribble will appear. Type in a text for it and confirm.

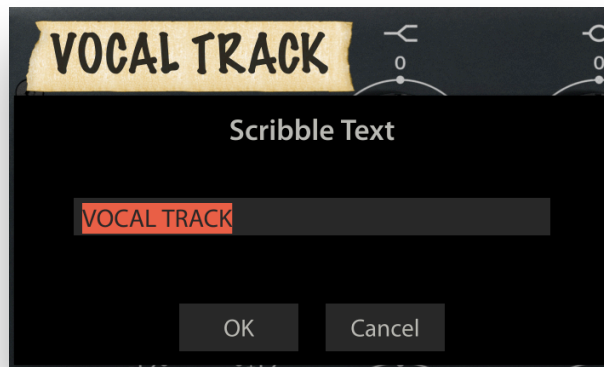

Scribbles can be customised to fit your needs. You can edit the scribble text and change its size by right clicking it and selecting the appropriate commands from the popup menu.



The same menu can be used to duplicate the scribble in case you need more copies on your interface. And of course you can delete the scribble if you don't need it anymore.

OVERLOUD GEMS

Here following is how a Gem interface with scribbles could look.



PREFERENCES

Each Gem has its own set of preferences to be set to customize its specific behaviour. The available preference settings can vary upon the specific Gem.

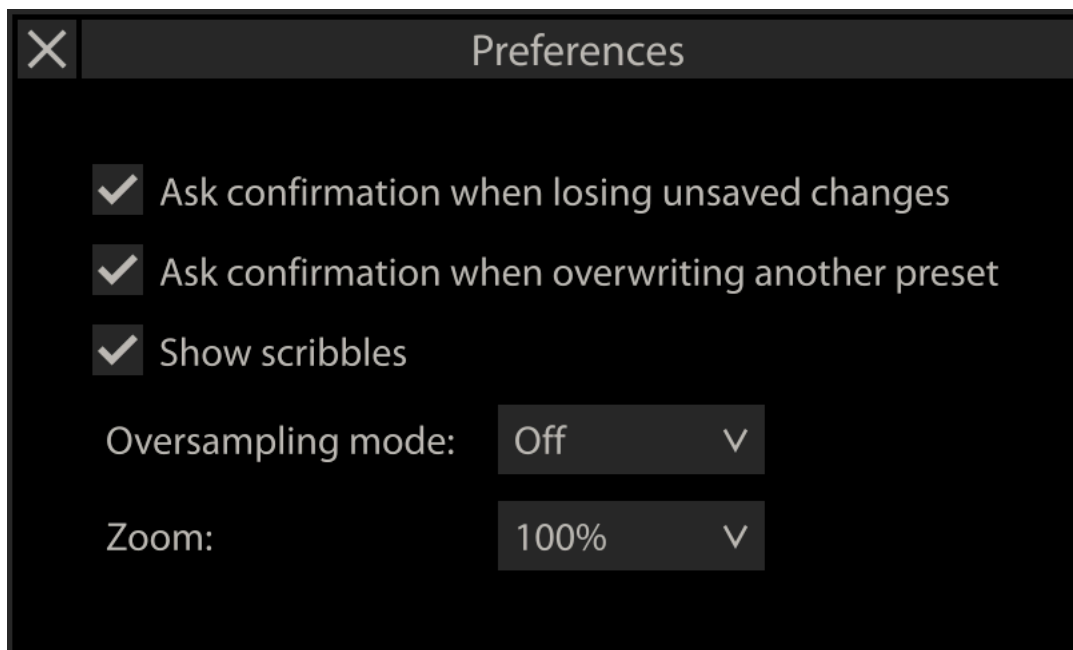

Ask confirmation when losing unsaved changes

Ask confirmation when overwriting another preset

Show scribbles

These are respectively related to: asking for a confirmation when you are about to lose changes that you haven't saved yet (i.e. if you load a preset after changing the current one), asking a confirmation when you are about to replace a preset by saving another one over it. And to show/hide the scribbles.

Oversampling mode

Oversampling is a technique used to reduce aliasing and to increase processing accuracy. Every time a digital sound processor introduces an harmonic distortion, a certain amount of aliasing is generated as a side effect. In common working situations, where the level of generated harmonics is generally low, there is no need for countermeasures. Hence, the default option, **Off**, is almost always good, because aliasing audio artefacts are inaudible.

When, on the other hand, high values of gain are used, the aliasing effect level could raise. For these cases, selecting **Standard** the processor performs an oversampling which effectively reduces aliasing.

Last setting, **Ultra**, is for extreme situations, where multiple high gain settings do overlap driving to a much distorted output. It's very likely that this situation never occurs in real cases.

The trade-off for oversampling are: CPU load and possible phase rotation on high frequencies. The higher the oversampling the greater the load on the CPU. And for plugins like the Gems, planned to be instantiated on a number of audio tracks, this really is something to take care of.

You may see that Oversampling is generally discouraged, especially when the label in the Preferences panel explicitly discourages its, because the plugin uses DSP techniques to increase the filter accuracy and reduce the aliasing, without the unwanted effects of the oversampling. Some

OVERLOUD GEMS

specific **Gems** do emulate units to be used at higher gain levels. For those ones, Oversampling might be a preference or even recommended.

VU-Meter calibration

Gems meters (or graphic displays) are calibrated to show a level of 0 VU when fed by a 1 KHz sine wave with a peak level of -14 dBFS, which is the factory calibration.

You can select one from a list of four: -8, -14, -18 and -21 dBFS.

Zoom

The graphic engine of all Gems supports the Zoom capability. The rendering scale factor can be changed making the whole graphic appearance larger or smaller respect to the standard size.

Different scale factors are available and at each new selection the interface window gets resized instantly.

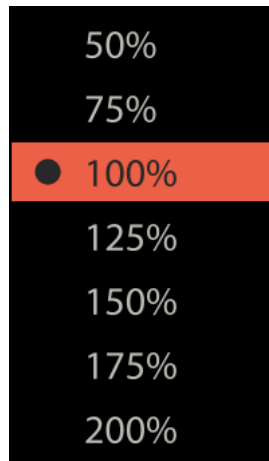

The Zoom feature is very handy when the Gem is working on a dense very high resolution display, for example. When the standard size would make it look small and hard to use.

Another typical situation is when the Gem is running on a smaller laptop display, and it has to cooperate with other windows by sharing smaller spaces. In this case a smaller percentage could be selected to reduce its size accordingly.

LEGAL NOTICE

All product names and trademarks are the property of their respective owners, and are in no way associated or affiliated with Overloud.

Product names and visuals are used solely for the purpose of identifying the specific source products that have been used as the basis for custom Overloud digital audio processing development, and to describe the types of tones produced by the Overloud products.

Any reference to these names or visuals does not imply any collaboration, cooperation affiliation, or endorsement. All rights reserved.