

User's Guide

for Echo™ Express SE I - Thunderbolt™ 3 Edition Thunderbolt 3 to PCIe Card Expansion Chassis

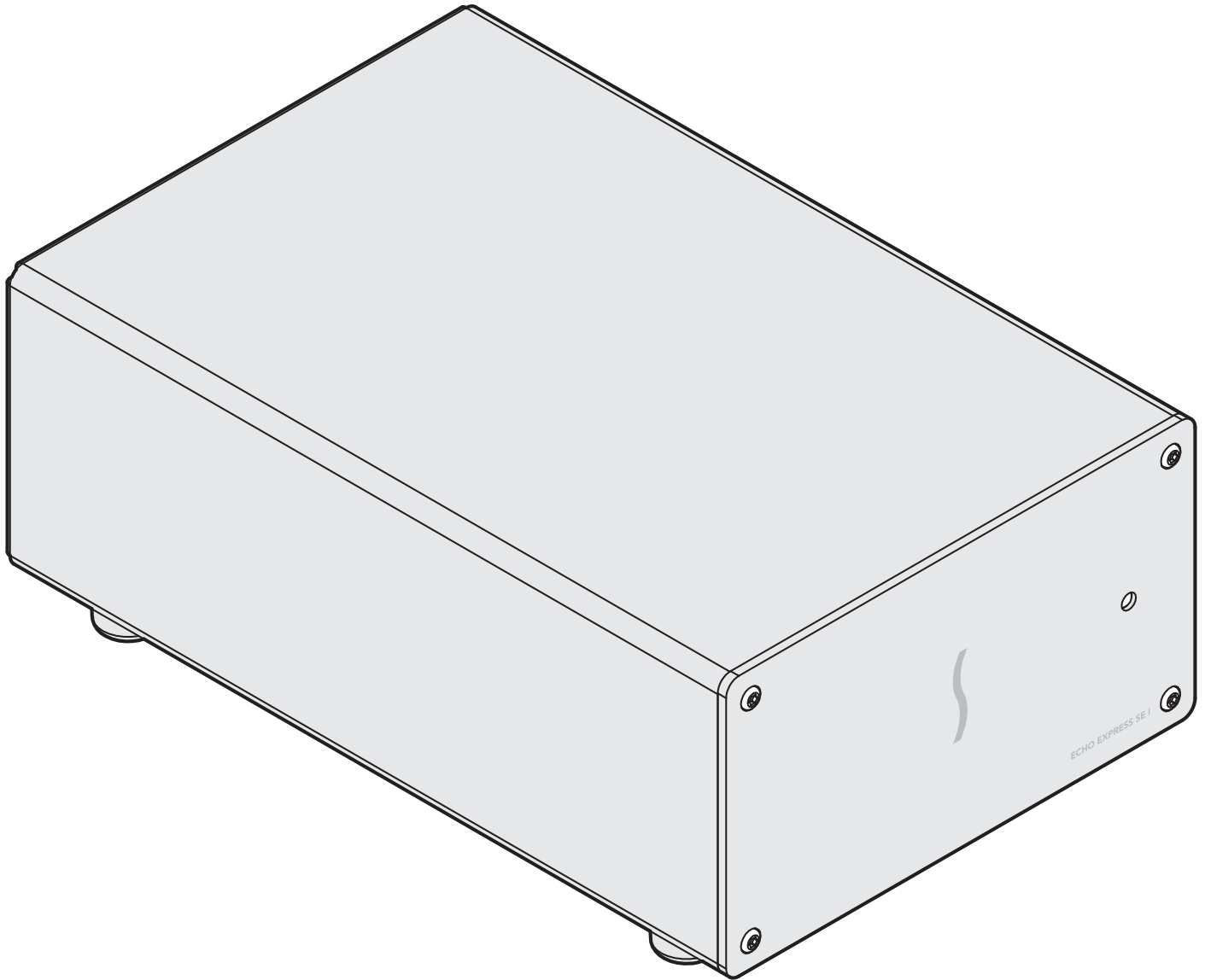

Support Note: This document was up to date at the time of printing. However, changes to the hardware or software may have occurred since then. Please check the Sonnet website for the latest documentation.

1. Go to www.sonnettech.com/support/kb/kb.php
2. Click the Thunderbolt Product link.
3. Click the Echo Express SE I - Thunderbolt 3 Edition link, and then click the Manual link.
4. Click the Echo Express SE I - Thunderbolt 3 Edition User's Guide [English] link and then check the Document Version information. If the version listed on the last page of this manual is later than this document (**revision D**), click the Download Now button for the latest version.



For
Windows



Contents

| | | |
|----------|--|-----------|
| 1 | Introduction, Compatibility, and Computer Preparation | 1 |
| | Introduction | |
| | Mac Compatibility | |
| | Windows Compatibility | |
| | Linux Compatibility | |
| | System Requirements | |
| | Preparing to Use the Echo Express Chassis With a Mac Computer | |
| | Preparing to Use the Echo Express Chassis With a Windows Computer | |
| | Preparing to Use the Echo Express Chassis With a Linux Computer | |
| 2 | Echo Express SE I - Thunderbolt 3 Edition (T3E) Description | 2 |
| | Echo Express SE I T3E Exterior | |
| | Echo Express SE I T3E Inner Assembly | |
| | Echo Express SE I T3E Power Adapter | |
| | Thunderbolt 3 (40Gbps) Cable | |
| | Thunderbolt Connector Retainer Clip | |
| 3 | PCIe Card Installation Steps | 4 |
| 4 | Complete Setup and Configuration | 7 |
| | Setup and Configuration Steps—Mac Users | |
| | Setup and Configuration Steps—Windows Users | |
| 5 | Tips, General Information, and Known Issues | 9 |
| | Tips, General Information | |
| | Known Issues | |
| 6 | Precautions, FCC Compliance, and Support Information | 10 |
| | Safety Precautions | |
| | FCC Compliance | |
| | Contacting Customer Service | |
| | Visit Our Website | |

Chapter 1 – Introduction, Compatibility, and Computer Preparation

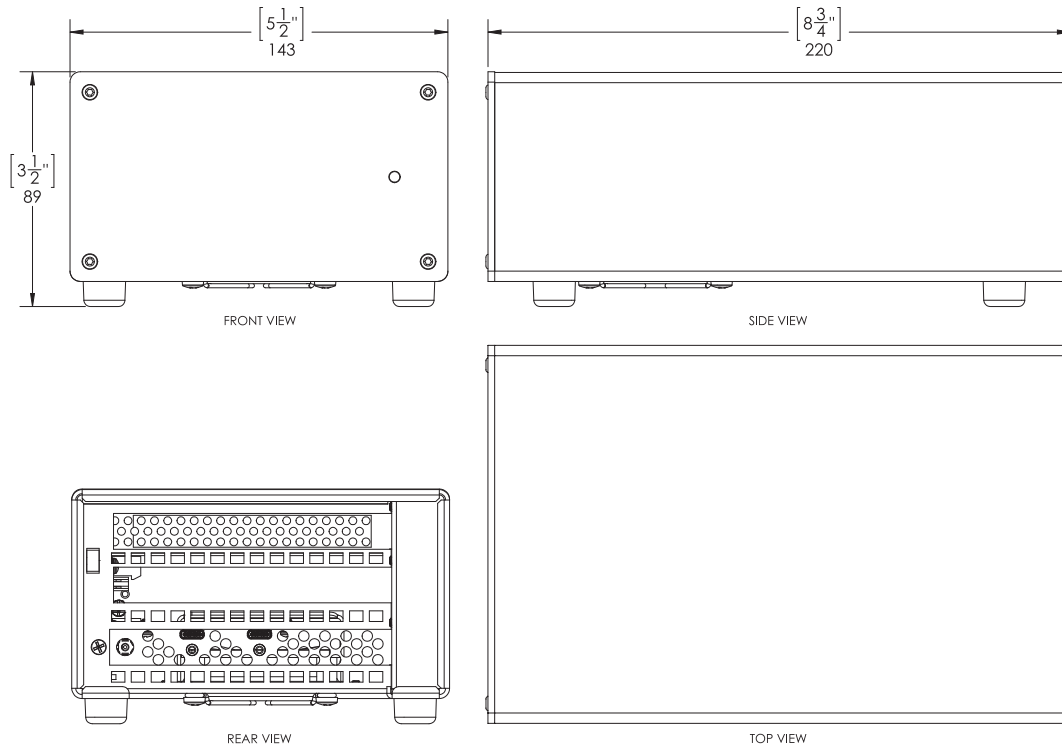

Introduction

Congratulations on your purchase! The Echo Express SE I - Thunderbolt 3 Edition (T3E) is a Thunderbolt 3 expansion system for PCIe cards. Through its PCIe slot, you may connect a half-length+ (up to 7.75 inches long), non-GPU expansion card to your computer with Thunderbolt 3 ports to expand its connectivity and capabilities.

Mac® Compatibility

- Macs with Thunderbolt 3 ports
- Macs with Thunderbolt 2 or Thunderbolt ports via an Apple Thunderbolt 3 (USB-C) to Thunderbolt 2 Adapter plus Thunderbolt cable (both sold separately)
- macOS® 10.12.6+
- macOS Mojave compatible

Windows® Compatibility

- PCs with Thunderbolt 3 ports
- Windows 10 (64-bit Edition Version 1809 or greater)

Important Note: Windows computers require the latest BIOS and Thunderbolt drivers to support this product. Check with your computer manufacturer for update information.

Linux® Compatibility

- Linux computers with Thunderbolt 3 ports
- Linux Kernel 5.0+

System Requirements

While Echo Express expansion systems require no drivers, most expansion cards you install do; Thunderbolt-compatible drivers to enable them to work properly through the Thunderbolt interface are required. More information on which cards are compatible with Echo Express SEL is available at: <https://sonnettech.com/support>

Preparing to Use the Echo Express Chassis With a Mac Computer

The drivers required to support the Echo Express chassis are installed as part of macOS; there are no preparation steps beyond updating your computer to macOS 10.12.6 or newer.

Preparing to Use the Echo Express Chassis With a Windows PC

1. Update Windows. You must use Windows 10, 64-Bit Version 1809 or newer. To check the version number, type *winner* in the search bar and click enter.
2. Update your computer's BIOS to the latest version. If you need help updating your BIOS, contact your computer manufacturer.
3. Update your Thunderbolt Bus Driver to the latest version; you will need version 16.3.61.275 or newer. To check your driver version, go to Settings:Apps:Thunderbolt(TM) Software and you will see the version number. If it is not 16.3.61.275 or newer, then you need to update it. Check with your computer manufacturer for an update.

Preparing to Use the Echo Express Chassis With a Linux Computer

The drivers required to support the Echo Express chassis are installed as part of Linux Kernel 5.0 and later; there are no preparation steps beyond updating your computer to Linux Kernel 5.0 or later.

Chapter 2 – Echo Express SE I - Thunderbolt 3 Edition (T3E) Description

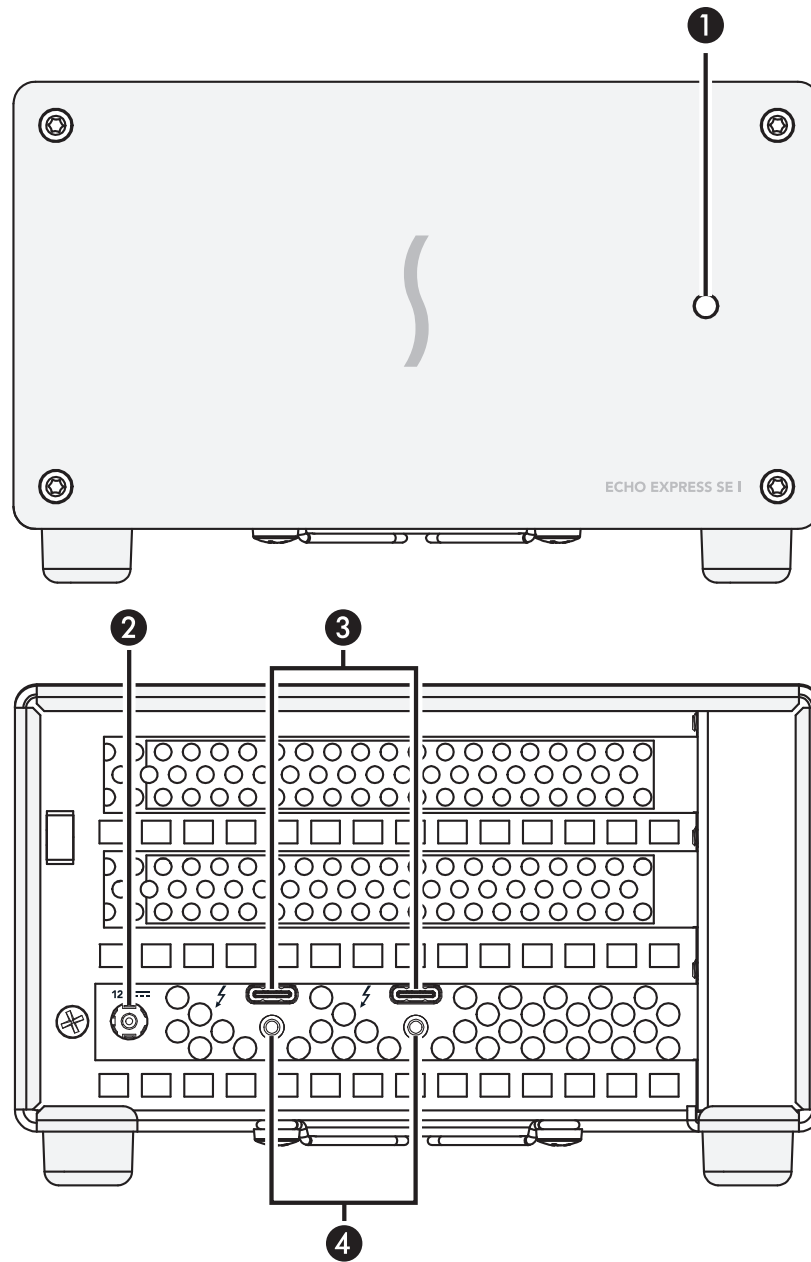

Echo Express SE I T3E Exterior

1 – Power Indicator

This lights when the Echo Express SE I T3E is powered, the Thunderbolt cable between the chassis and your computer is plugged in securely, and the computer powered on. Note that if the Echo Express SE I T3E is connected to another Thunderbolt device instead of directly to the computer, any other Thunderbolt device connected between the computer and Echo chassis must also be powered on before the Echo chassis' power indicator will light up.

2 – 12V DC Socket

Connect the included DC power adapter to this connector.

3 – Thunderbolt 3 Ports

Connect the included Thunderbolt 3 (40Gbps) cable between either port and your computer's Thunderbolt port (or other Thunderbolt device in the chain connected to the computer).

The second port may be used to connect to another Thunderbolt peripheral device, display(s), or USB device (when connected with the proper cable or adapter).

4 – Threaded Nuts for ThunderLok 3

Attach the included Thunderbolt connector retainer clip here. Also compatible with ThunderLok 3L.

Chapter 2 – Echo Express SE I - Thunderbolt 3 Edition (T3E) Description

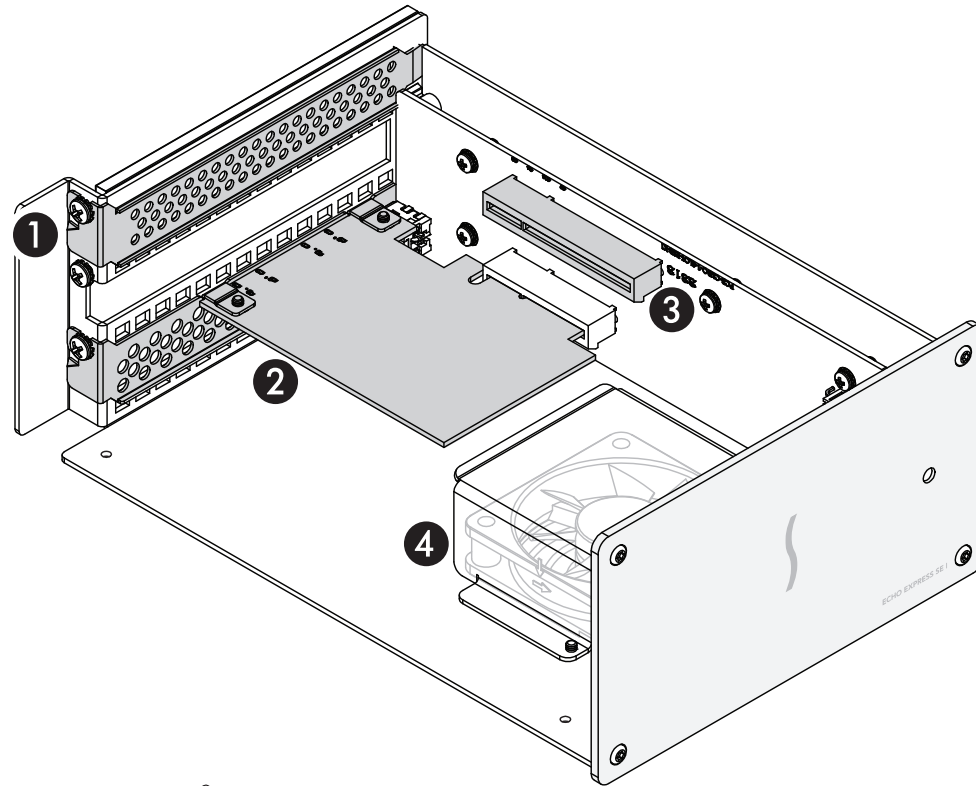

Echo Express SE I T3E Inner Assembly

1 – Port Access Cover

This covers the opening in the chassis when a single-width PCIe card with no daughter card is installed in the PCIe slot.

2 – Thunderbolt Interface Card

This is installed into its own slot and may not be moved to the PCIe slot.

3 – PCIe Slot

This is an x8 mechanical (x4 electrical) PCIe 3.0 slot. It is also compatible with PCIe 2.0 and 1.1 cards.

4 – Fan

The temperature-controlled fan provides cooling for the installed PCIe card and the chassis' supporting Thunderbolt circuitry. It operates at a whisper when the card is running cool, and speeds up when the temperature rises. Do not block the fan or the vent holes on the back of the chassis to prevent overheating.

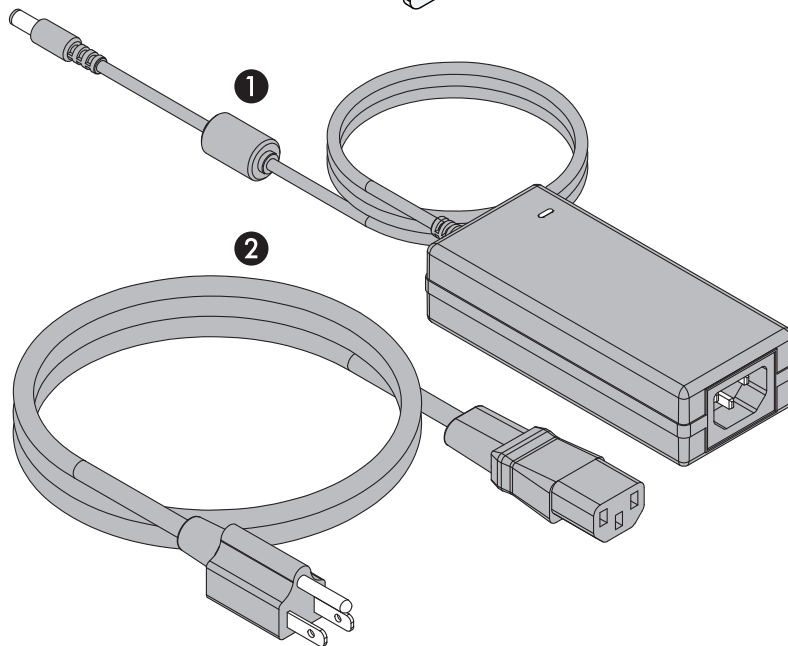

Echo Express SE I T3E Power Adapter

1 – Power Adapter

Connect this to the Echo Express SE I chassis' power port. Note that the power indicator on top lights when the adapter is connected to AC power.

2 – Power Cord

Connect this between a power outlet and the power adapter. Note that the power cord included with your product may appear different than the one pictured here, depending on where the product was purchased.

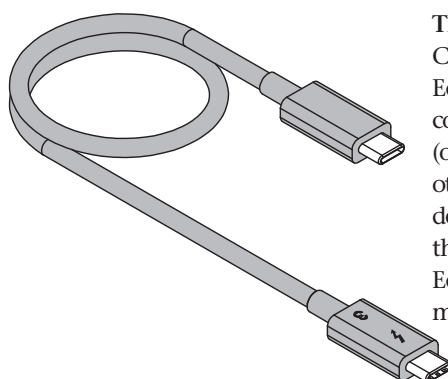

Thunderbolt 3 (40Gbps) Cable
Connect this cable between the Echo chassis and one of your computer's Thunderbolt 3 ports (often indicated by a \mathcal{T} logo), or other Thunderbolt peripheral device in the chain connected to the computer. Connecting the Echo chassis to a computer port marked with the USB icon () is NOT supported.

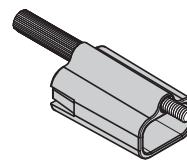

Thunderbolt Connector Retainer Clip

This clip secures the Thunderbolt 3 connector plugged into one of the Echo chassis' Thunderbolt 3 ports to prevent accidental cable disconnection. This clip is compatible with Sonnet 0.5- and 0.7-meter Thunderbolt 3 cables, but not with Sonnet 1- or 2-meter Thunderbolt 3 cables (which require ThunderLok 3L, part number TB3-LOK2L).

Chapter 3 – PCIe Card Installation Steps

1. Remove the Echo Express SE I - Thunderbolt 3 Edition (T3E) chassis from its packaging, and then set it upside-down on a soft, flat, level surface.
2. Remove and set aside the four screws securing the feet to the bottom of the outer case (Figure 1). Set aside the screws and feet.



Support Note: To avoid damaging components due to static electricity discharge, wear an antistatic wrist strap while working inside Echo Express SE I T3E.

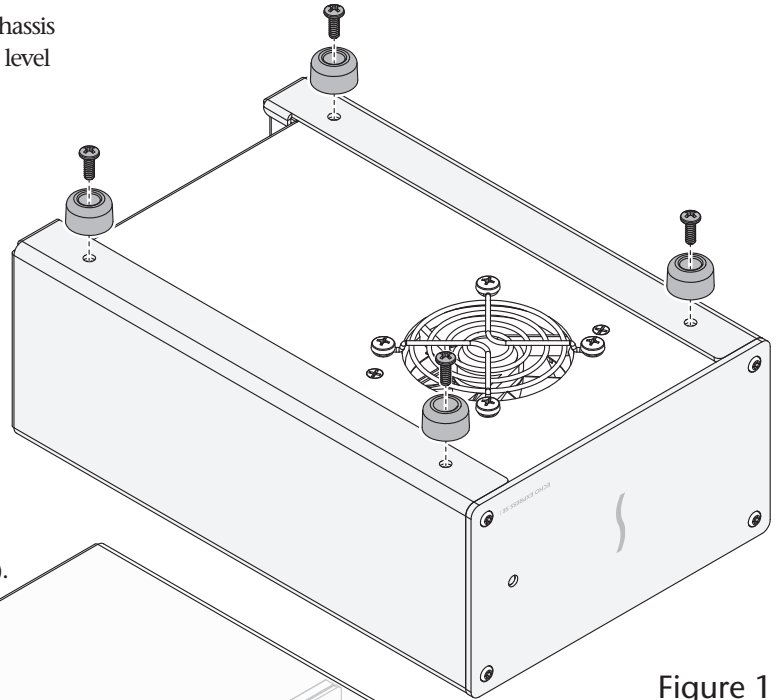

Figure 1

3. Turn the Echo Express SE I T3E chassis right-side up (Figure 2).
4. Place one hand on top of the outer case. Remove the inner assembly by gently grasping its faceplate by the edges and pulling (Figure 2). Set aside the outer case.

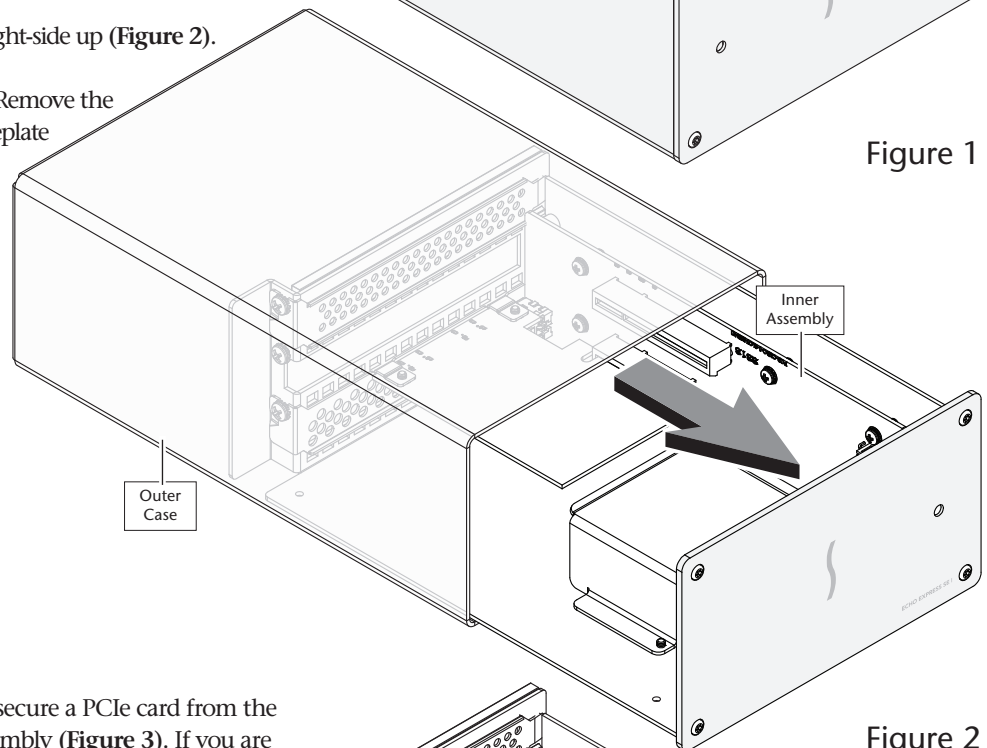

Figure 2

5. Remove and set aside the screw used to secure a PCIe card from the Echo Express SE I T3E chassis' inner assembly (Figure 3). If you are installing a double-width card, or an additional daughter card, remove and set aside the screw securing the port access cover, and then remove and set aside the cover.

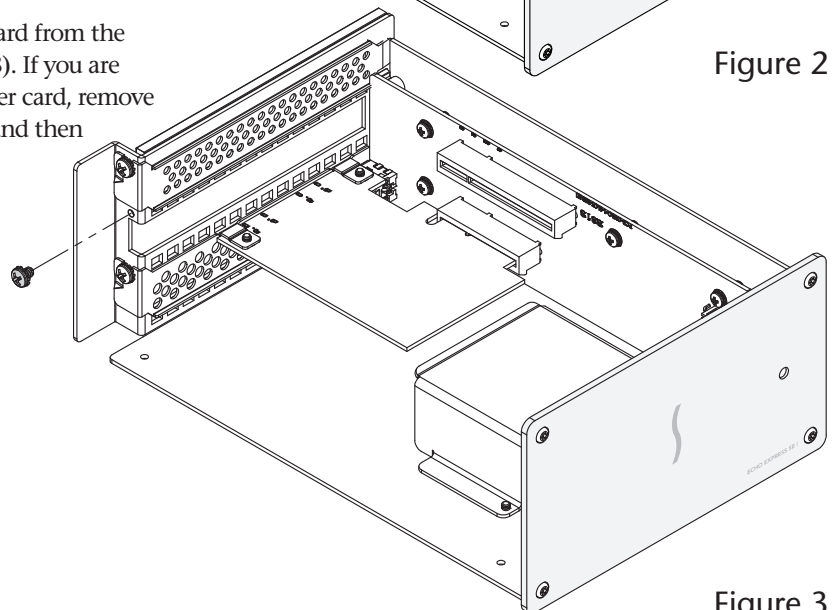

Figure 3

Chapter 3 – PCIe Card Installation Steps



WARNING: When handling computer products, take care to prevent components from being damaged by static electricity; avoid working in carpeted areas. Handle expansion cards only by their edges and without touching any components or gold connector pins. Also, avoid touching the Echo Express SE I T3E chassis' circuit boards and any of its components.

6. Remove the PCIe card from its packaging, handling the card by its edges and without touching any components or gold connector pins.

7. Holding the card with its bracket on the left and the connector pins facing away from you, line up its connector with the slot, and then gently but firmly insert the card straight into the slot; **do not rock the card or force the card into the slot**. If you encounter excessive resistance, check the card's connector and the slot for damage, and then try inserting the card again (Figure 4).

8. Secure the card using the screw you removed previously; do not overtighten the screw (Figure 4).

9. If the PCIe card you installed included a daughter card, connect them together with the cables included with the PCIe card, and then install the daughter card into the Echo chassis. Secure the daughter card with the screw that previously secured the port access cover.

10. Place one hand on top of the outer case, and then gently push the inner assembly back into the outer case (Figure 5).

11. Turn the Echo Express SE I T3E chassis upside-down, and then secure the outer case to the inner assembly by reattaching the four feet; do not overtighten the screws (Figure 6).

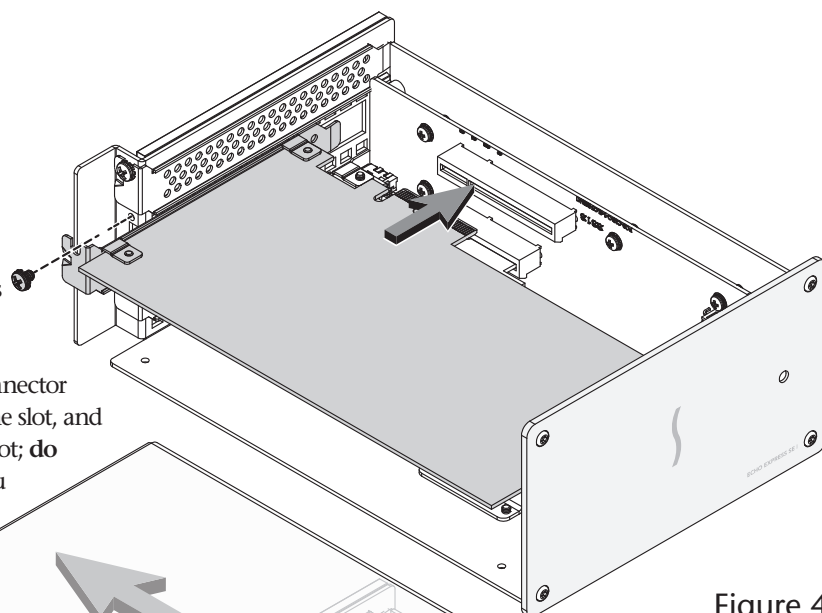

Figure 4

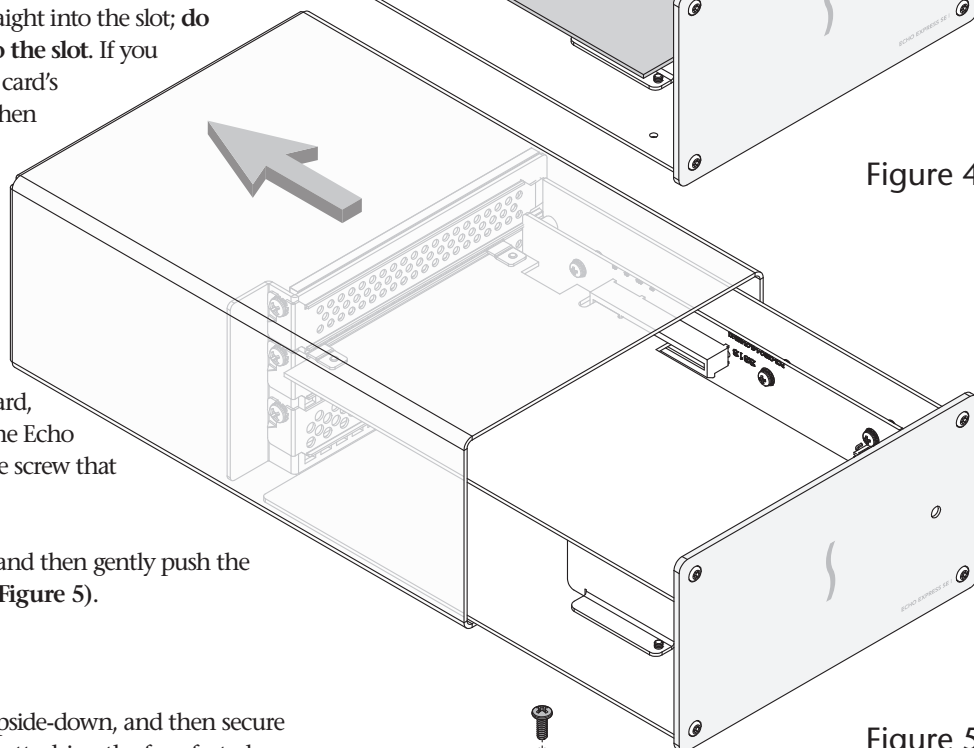

Figure 5

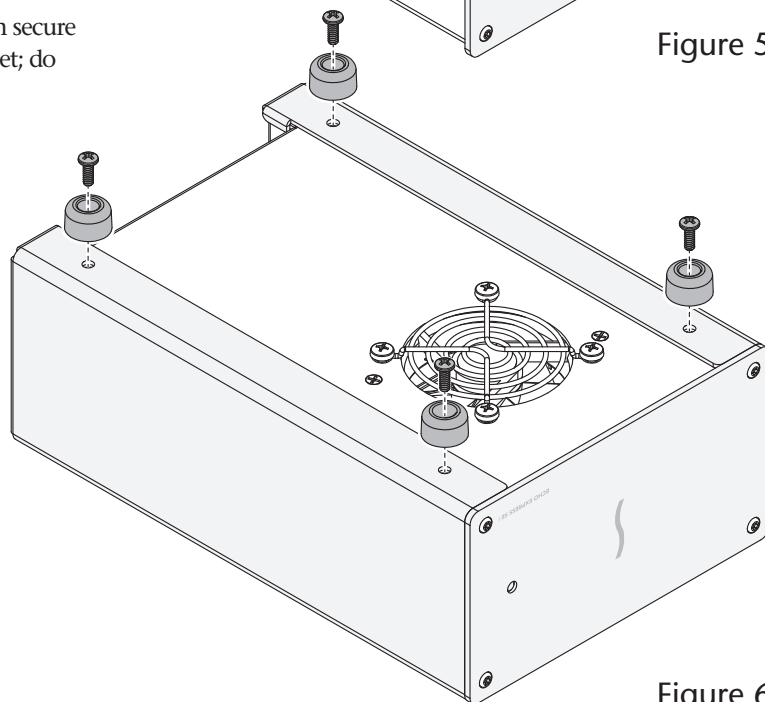

Figure 6

Chapter 3 – PCIe Card Installation Steps



Support Note: Sonnet's ThunderLok™ 3 Thunderbolt connector retainer clip secures the included Thunderbolt 3 (40Gbps) cable to the Echo chassis to prevent accidental disconnects. The included clip is compatible with Sonnet 0.5- and 0.7-meter Thunderbolt 3 (40Gbps) cables, but it is not compatible with Sonnet 1- or 2-meter Thunderbolt 3 (40Gbps) cables.

To attach the clip to the cable, remove both items from their packaging, and then insert the connector through the connector clip as shown (Figure 7). Note that the connector will pass all the way through the clip; when you connect the cable to the chassis, the clip will secure the connector.

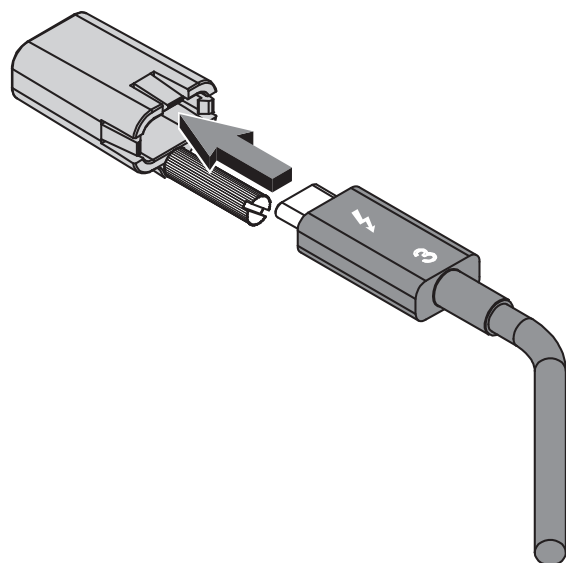

Figure 7

12. Turn the Echo Express SE I T3E right-side-up.
13. Connect the included Thunderbolt cable (or a comparable Thunderbolt 3 [40Gbps] cable) between a Thunderbolt 3 port on the Echo chassis and a Thunderbolt 3 port on your computer, or other Thunderbolt device in the chain connected to the computer (Figure 8). Note that cables or ports marked with the USB icon (🔌) are NOT compatible. Secure the retainer clip to the chassis if you attached it. If you are daisy chaining additional Thunderbolt devices, connect another Thunderbolt cable between the downstream device and the open Thunderbolt port on the Echo chassis.
14. Connect the included power cord between a wall outlet or power strip and the power adapter; verify the connector is plugged in securely. Note that the power adapter's power indicator will light at this time.
15. Connect the power adapter cable to the Echo chassis 12V power socket. Note that the power indicator on the Echo Express SE I T3E chassis will not light until the computer, and any other Thunderbolt device connected between it and the Echo chassis, is powered on.

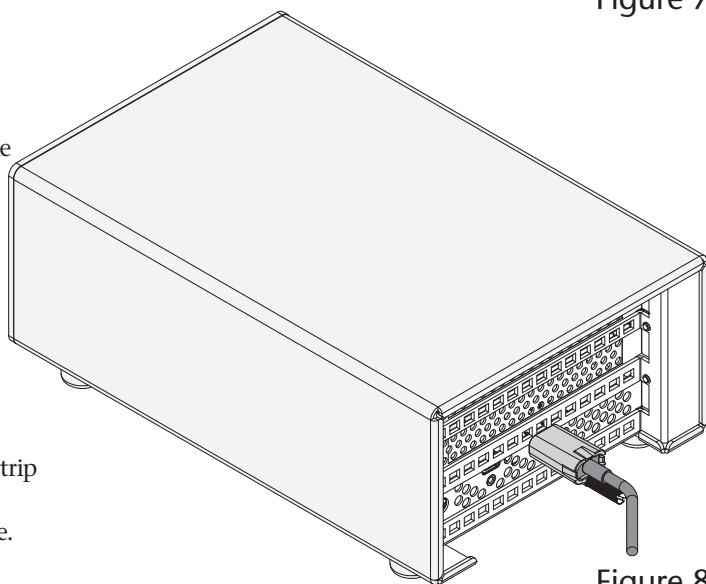

Figure 8

Chapter 4 – Complete Setup and Configuration

SETUP AND CONFIGURATION STEPS—MAC USERS

This page instructs Mac users how to verify the Echo chassis and installed card are recognized by the computer; Windows users should skip to the next page.

A – Confirm the Echo Express SE I T3E Chassis is Recognized

1. With the Echo chassis powered and connected to the computer, turn on the computer. Note that if there are any other Thunderbolt devices connected between the Sonnet chassis and your computer, they must also be powered for you to perform the following steps.
2. Press and hold down the Option key, and then from the Apple menu, select System Information; a *System Information* window will open.
3. In the *System Information* window, click Thunderbolt under the Hardware header in the left column (Figure 9).
4. In the top right column under the Thunderbolt Device Tree header, you will see Thunderbolt Bus, and then “Echo Express SE I TB3” (Figure 9).



Support Note: If you do not see “Echo Express SE I TB3” listed, disconnect and reconnect the Thunderbolt cable between the computer and Echo Express SE I T3E. Note that it is not necessary to shut down the computer before disconnecting and reconnecting the cable, so long as the installed card is Thunderbolt-compatible.

B – Confirm the Installed Card is Recognized

1. In the *System Information* window click PCI under the Hardware header in the left column (Figure 10).
2. At the top of the right column, the installed card is listed. You should see “Yes” next to Driver Installed and Tunnel Compatible, otherwise the card or driver may not be Thunderbolt-compatible, otherwise the card or driver may not be Thunderbolt-compatible (Figure 10).



Support Note: While the Echo Express SE I T3E expansion chassis requires no drivers of its own, the installed card requires Thunderbolt-compatible drivers to enable its use.

C – Install Card Drivers, If Necessary

1. Launch a web browser, and then go to your card manufacturer’s website. Download and install the latest drivers according to the manufacturer’s directions.
2. Restart your computer; your Echo chassis is ready to use!

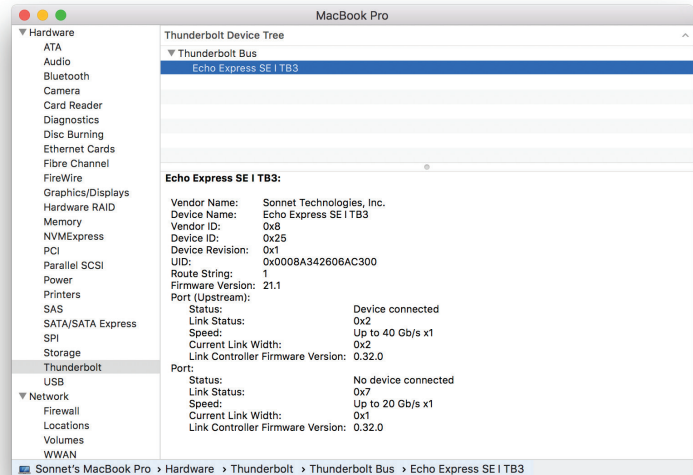

Figure 9

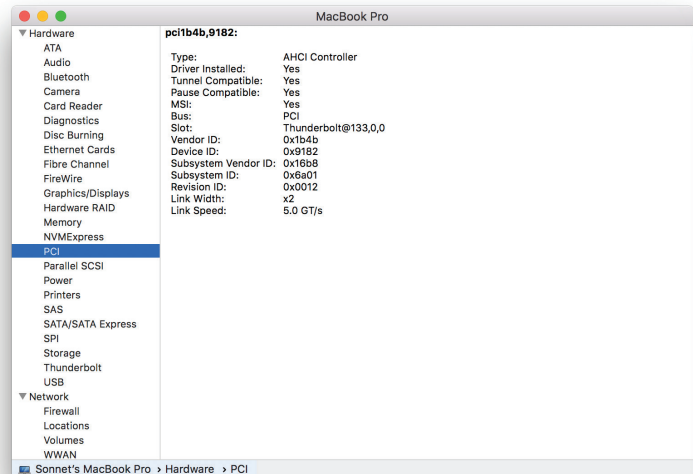

Figure 10

Chapter 4 – Complete Setup and Configuration

SETUP AND CONFIGURATION STEPS—WINDOWS USERS

A – Confirm the Echo Express SE I T3E and Installed Card Are Recognized

1. With the Echo chassis connected to a power source and to the computer, turn on the computer. Note that if there are any other Thunderbolt devices connected between the Sonnet adapter and your computer, they must also be powered for you to perform the following steps.
2. When the computer boots for the first time after you connected the Echo Express SE I T3E, an *Approve New Thunderbolt™ Devices* window appears. From the drop-down menu select *Always Connect*, and then click *OK*.
3. Right-click the Windows Start button, and then select *Manage*; the *Computer Management* window appears.
4. In the *Computer Management* window, click the category for the card type you installed to expand the listing; a generic adapter listing will appear. After its drivers are installed, the listing will change to display the name of the installed card.

B – Install Card Drivers, If Necessary

1. Launch a web browser, and then go to your card manufacturer's website. Download and install the latest drivers according to the manufacturer's directions.
2. Restart your computer; your Echo chassis is ready to use!

Chapter 5 – Tips, General Information, and Known Issues

TIPS, GENERAL INFORMATION

Keeping the Card Cool

With its optimized airflow design and temperature-controlled fan providing cooling at all times, Echo Express chassis provides adequate cooling for the installed card. *Do not operate the Echo chassis with its cover off, and do not block any of the vents!* Otherwise, the installed card and Echo chassis' components may overheat.

Hot Plugging the Echo Express Chassis

When a certified Thunderbolt-compatible card (used with Thunderbolt-compatible drivers) is installed in the Echo chassis, you may connect and disconnect the chassis while the computer is on. Of course, if you have anything connected to the card, such as storage devices, cameras, etc., follow proper procedures for disconnecting those devices before unplugging the Echo chassis.

There's No Need to Unplug the Power Adapter

Because an Echo Express chassis automatically powers on and off with the computer to which it's connected, there's no power switch, nor is there any need to disconnect the power cable under normal use.

Power Indicator LED Operation

Because the Echo chassis automatically powers on and off with the computer to which it's connected, its power indicator only lights when the computer is on, and turns off when the computer is sleeping or powered off. Note that the power adapter's power indicator remains lit as long as the adapter is connected to a live power outlet.

Connecting Additional Thunderbolt 3 Peripheral Devices

The Echo Express chassis includes two Thunderbolt 3 ports; the first is reserved for connection to your computer, while the second supports daisy-chaining of up to five additional Thunderbolt peripheral devices.

Using Expansion Cards Without Additional Drivers

Some Thunderbolt-compatible expansion cards, like Sonnet's Allegro™ Pro USB 3.1 PCIe cards, use inbox (built into the operating system) drivers, and are ready to use out of the box.

Replacing a Card After Initial Installation

Shut down the computer, and then disconnect the power adapter and Thunderbolt cables from the Echo Express SE I T3E before opening the chassis and replacing the card.

PCIe CARDS ARE NOT HOT-PLUGGABLE!

Never install a PCIe card into Echo chassis while it is connected to a computer or power outlet! If you do, you risk injury, and damage to the card, chassis, and computer.

Echo Express SE I T3E Provides Upstream Power

The Echo Express SE I T3E can provide up to 15 watts to bus-powered Thunderbolt 3 peripheral devices, enabling them to operate without connecting an additional power adapter.

Using the Echo Chassis to Charge Your Notebook or Laptop Computer

Apple® MacBook Air® and MacBook Pro®, and some PC laptop computers with Thunderbolt 3 may be charged *slowly* via the Echo chassis' Thunderbolt 3 port (via 15W Power Delivery). Computers with Thunderbolt 2 or Thunderbolt ports cannot be charged via Thunderbolt.

How to Identify Thunderbolt 3 (40Gbps) Cables

Look for the Thunderbolt icon (⚡) AND the number 3 on the connector housings to identify these cables. Cables with USB-C connectors that only have the Thunderbolt icon without the number 3 may only support 20Gbps speeds, and are not recommended for PCIe cards with high bandwidth requirements. Cables marked with the USB icon (🔌) are NOT compatible for connecting the Echo chassis to the computer.

KNOWN ISSUES

Not All Computers' Thunderbolt 3 Performance is Equal

While this product features a 40Gbps Thunderbolt 3 interface, some computers equipped with Thunderbolt 3 use an implementation of Thunderbolt 3 that limits PCIe performance to 20Gbps. Mid-2017 and earlier 13-inch MacBook Pro computers with four Thunderbolt 3 ports have this limitation in the two right-hand Thunderbolt 3 ports, while offering full performance from the left-hand ports.

Not all PCIe Cards Will Perform at 100%

Thunderbolt 3's PCIe bandwidth is limited to 40Gbps. While most cards will operate at full performance, some may not due to the fact they require more bandwidth than Thunderbolt 3 is capable of supporting.

Not All Thunderbolt 3 Cables Deliver Full Performance

Full performance from the Echo chassis requires the use of the included Thunderbolt 3 (40Gbps) cable (which also supports up to 100W power delivery), or a comparable Thunderbolt 3 cable. When shopping for a Thunderbolt 3 cable, please be aware that some support only lower data transfer speeds (20Gbps) and/or power delivery capabilities.

Operating System (OS) Updates May Break Compatibility

Specific device drivers that work under one OS version may not work under a later version. Before updating your computer to the latest OS, we recommend that you contact Sonnet or your PCIe card's manufacturer to verify that the existing drivers work. Note that other software updates for the computer may also break compatibility.

Some Devices' Performance May be Affected by Where They Are Connected in a Thunderbolt Chain

However small, Thunderbolt introduces latency to a device chain. If you expand with additional Thunderbolt expansion chassis, you may need to experiment with which cards work better in chassis closer to or farther from the computer in the chain.

Chapter 6 – Precautions, FCC Compliance, and Support Information

SAFETY PRECAUTIONS

Please read this section carefully before proceeding. These precautions explain the correct and safe use of this device, thereby helping to prevent injury to you or others, and also help you to minimize the risk of damaging the device.

Warnings

Always follow the basic warnings listed here to avoid the risk of serious injury or death from electrical shock, short-circuiting, fire, and other hazards. These warnings include, but are not limited to:

- Do not attempt to modify the enclosure. If this device appears to be malfunctioning, contact your reseller or local distributor
- Do not drop the chassis; dropping or mishandling the chassis may result in a malfunction leaving the product inoperable
- Do not expose the device to rain, use it near water or containers that contain liquids which might spill into any openings, or in damp or wet conditions
- If unusual smells, sounds, or smoke come from the device, or if liquids enter it, switch it off immediately and unplug it from the electrical outlet
- Follow the instructions in this manual carefully; contact your reseller or local distributor for additional advice not covered in this User's Guide

FCC Compliance

Echo Express SE I - Thunderbolt 3 Edition complies with Part 15 of the FCC Rules. Operation is subject to the following two conditions: This device may not cause harmful interference, AND this device must accept any interference received, including interference that may cause undesired operation.

Contacting Customer Service

The Sonnet Web site located at www.sonnettech.com has the most current support information and technical updates. Before you call Customer Service, please check our Web site for the latest updates and online support files, and check this User's Guide for helpful information.

Email support requests generally receive the fastest responses, and are usually processed within a 24-hour period during normal business hours, excluding holidays. When you contact Customer Service, have the following information available so the customer service staff can better assist you:

- Product name
- Date and place of purchase
- Computer model
- PCIe card model
- Operating system version
- Software/firmware versions
- A System Report (macOS) or a Microsoft System Information MSINFO32 (Windows) report (Windows), along with a description of the issue(s) you are encountering with your device

If further assistance is needed, please contact us at:

USA, Canada, or Mexico Customers

Please contact **Sonnet Customer Service** at:

E-mail: support@sonnettech.com

Tel: 1-949-472-2772

(Monday–Friday, 9 a.m.–5 p.m. Pacific Time)

For Customers Outside North America

For support on this product, contact your reseller or local distributor.

Visit Our Web Site

For the most current product information and online support files, visit the Sonnet Web site at www.sonnettech.com. Remember to register your product online at <https://registration.sonnettech.com> to be informed of future upgrades and product releases.

