



**Darkglass® Electronics**

*Your vision, our gear.*

CREATIONS

DEALERS

SUITE

APPAREL



# Alpha·Omega 900 Manual

900W Bass Amplifier

[Specs](#)

[Block Diagram](#)

[Warning](#)

[Warranty](#)

## Specs

### Controls

**Passive/Active:** Use this push-button switch to change from passive to active mode. If your bass is active it can have a hotter signal making the amp to distort early (feel free to use if such additional distortion is desired).

**Distortion:** Use this push button to turn on or off the Alpha·Omega Engine to add natural compression, organic harmonic enhancement, and saturation ranging from mild overdrive to high gain bass rage.

The Alpha·Omega Engine operates before the clean section (you can therefore use the 6-Band Active EQ for additional tone shaping).

**Bite:** Boosts high mids (2.8kHz) for additional presence and definition.

**Growl:** Shelving Bass Boost for a fatter tone and increased low end saturation.

**Compression:** This knob controls the amount of dynamic compression added to the Alpha·Omega Engine. The

make up gain is adjusted automatically. The compression can be turned off or assigned using the Darkglass Suite.

**Drive:** This knob controls the amount of distortion that the Alpha·Omega Engine will deliver. It will change from a soft, warm overdrive to a massive and modern distortion sound.

**Level:** Use this knob to control Alpha·Omega Engine's output volume.

**Blend:** Use this knob to mix between the Clean signal and the Distortion signal (Alpha·Omega Engine).

**Mod:** Selects or mixes between the two distinct distortion circuits: Alpha is punchy, tight with a lot of definition, whereas Omega is simply brutal and raw.

**Gain:** Use this knob to change the volume of the signal before the Active 4 Band EQ. You can set it low for ensuring the cleanest operation possible or set it higher for a more aggressive growl.

**Bass:**  $\pm 12$ dB at 80Hz. Use this knob to change the low-end content of the signal.

**Mids:**  $\pm 12$ dB at 250, 500, 1.5K and 3kHz. This graphic EQ control the mid content of the signal.

**Treble:**  $\pm 12$ dB at 5kHz. Use this knob to change the high content of the signal.

**Master:** Use this knob to control the overall volume of the amplifier.

**Mute:** Use this push button to mute the amplifier.

## Technical Specifications

**Input Impedance:** 1 M $\Omega$

**Minimum Load Impedance:** 4  $\Omega$  (2  $\Omega$  in 2  $\Omega$  mode)

**Maximum Power Output:** 900 W RMS @ 4  $\Omega$  (1 kHz full blast, 2 min. max) 20% THD, 450 W RMS @ 8  $\Omega$

**Power Amp Input Impedance:** 1 M $\Omega$

**Power Amp Input Level:** 4  $\Omega$  mode: 1500 mV RMS, 2  $\Omega$  mode: 1200 mV RMS

**Pre-Amp Output Impedance:** 1 k $\Omega$

**Pre-Amp Output Level:** 1200 mV

**Maximum Power Consumption:** approx. 700 VA

**Cooling:** Forced-air cooled

**AC Input Power:** 100–250 VAC

**AC Frequency:** 50/60 Hz

## Dimensions

**Width:** 26.7 cm / 10.5"

**Length:** 25.5 cm / 10"

**Height:** 7 cm / 2.75"

**Weight:** 2.9 kg / 6.39 lb

## Block Diagram

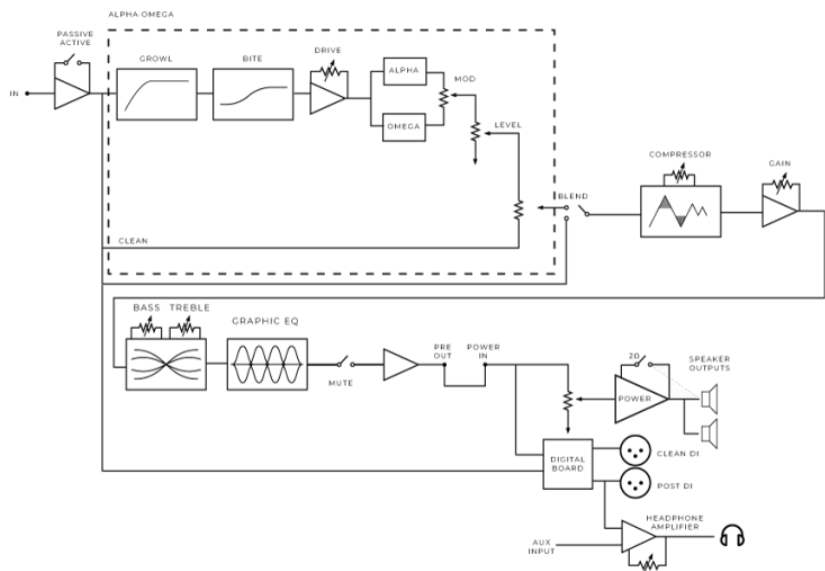

## Warning

- No user serviceable parts inside the amplifier. Do not open the amp.

- Never use the amp at a high moisture environment or near liquids.
- The Alpha·Omega 900 can deliver more than 115 dB of power. Exposure to this level of sound can damage your hearing. Use proper hearing protection if you will be exposed.
- The Alpha·Omega 900 can deliver more than 900 Watts. Be sure that your speaker cabinet is able to deliver that power. You can reduce the output of the amp by selecting the 2Ω mode on the rear panel (by the SpeakON output jack).
- Do not cover the vent holes. The Fan and vent holes are part of the cooling system of the amp. Covering the vent holes can damage the power amp by overheating it.
- Don't use an instrument cable as speaker cable. An instrument cable is not designed to deliver the type of power signals sent from the amplifier to the speaker.

## Troubleshooting

- The button controls do not react: check if the footswitch is connected. If you do not want to use the footswitch, you have to unplug the cable from the rear back of the amp.
- The amp does not turn on: check if the power cable is connected and if you have power on the wall.
- The sound is low: check your speaker cable. Never use instrument cable.
- The sound is distorted or too high: check if the passive active switch match your bass.

## Warranty

Please register for your warranty at <http://mypedal.darkglass.com>. The Alpha·Omega 900 is under warranty to the original owner for a period of two years against manufacturing defects in the country where the product was originally purchased.

If you experience a problem with the unit, please contact [support@darkglass.com](mailto:support@darkglass.com) to receive a Return Authorization number or for information on the nearest authorized repair center. A copy of your original receipt must be included with all warranty repairs. You are responsible for all shipping charges. The unit must be shipped to us freight prepaid. We will return the unit freight collect.

Darkglass Electronics OY is not responsible for shipping damage either to or from our service center. Claims must be filed with the carrier. For repairs please contact your local dealer or distributor for your country's specific warranty period and repair procedures.

Alpha·Omega® is a registered trademark of Darkglass Electronics OY.



[PRIVACY POLICY](#)

[CAREERS](#)



DARKGLASS is a registered trademark in the U.S., number 4,616,801, owned by Darkglass Electronics Oy.

Designed by Revolve Studio